

Bücker JUNGMEISTER

Bü133 1/5

Building Instructions



Specifications

Wing Span	1320 mm / 52.0"
Wing Area	41,3 sq dm / 4.13 sq ft
Structure weight	1200 Gramm / 42.33 oz.
Flying weight	2200 Gramm / 77.60 oz.
Fuselage length	1150 mm / 45.28"
Scale	1 / 5

Requires

RC transmitter with at least 5 channels
2 x servos for ailerons (approx. 20 grams)
2 x servos for elevator and rudder (approx. 40 grams)
Motor system (from approx. 600 watts power)



Tony Ray's AeroModel

BEFORE YOU BEGIN

Attentions and Tips

1. Read through the manual before you begin, thus you will have an overall idea of what to do.
2. Check all parts in the scope of delivery list. If you find any serious defects or missing parts, please contact Tony and Sebastian directly.
3. Please build your kit in strict accordance with the sequences in the user manual.
4. Pre-Sanding: Before removing any parts from the laser-cut plywood sheets, use some 250 -400 grit sandpaper and lightly sand the back side of the sheet. This is significantly reducing burn marks of the wood and makes the parts match better together.
5. Before building the for example the wings with the wing drawing, it is recommended to cover the paper with a layer of kitchen cling film. This way, you can prevent wood parts from sticking to the drawing and causing damage.
6. Parts Assembly: This products tabs and notches interlock like a 3D puzzle. We highly suggest that when fitting parts, you “dry fit” (use no glue) the parts first. It is advised to work 1 - 2 steps ahead in the instructions, using the dry-fit technique. This allows to inspect the fit and location of assembled components first. Once you arrive at the end of a major assembly sequence, prepare your work on a flat surface and then bond the dry-fit joints with glue. Using the dry-fit technique, you will be able to recover from some minor building mistakes.
7. This is a precision laser-cut kit. Our lasers cut within 0.2mm accuracy. Yet the sheets of our wood supplier may vary in thickness by up to 0.2-0.3mm. This variance in the wood stock can cause some tabs and notches to fit very tightly. So please consider lightly sanding or lightly pinching a tight-fitting tab before assembling rather than forcing the parts together.

KIT INVENTORY











Wood Sheet Inventory





Item:	Quantity	Mark
2.0mm Paulownia	11	A Series: A1-A11
3.0mm Plywood	3	B Series: B1-B3
2.0mm Plywood	4	C Series: C1-C4
3.0mm Paulownia	4	D Series: D1-D4
3.0mm Balsa	2	E Series: E1-E2
1.0mm Balsa	5	F Series: F1-F5
1.0mm Hard Plywood	1	G Series: G1
5.0mm Balsa	1	H Series: H1
1.0mm Soft Plywood	7	Unmarked

Wood Strips & Strip Parts Inventory

Item:	Quantity
3*3mm Balsa, Length: 72+18cm	4
6*6mm Balsa, Length: 72+18cm	3
3*3mm Pine, Length: 72+18cm	6
6*2mm Pine, Length: 72+18cm	20
8*2mm Pine, Length: 72+18cm	2
PVC Tube (Outer Φ : 3mm, Inner Φ : 2mm), Length: 72cm	2
Steel push rod (Diameter 1.2mm), Length: 72cm	2
Pine rod Φ 6 mm, Length: 50cm	2
Steel cable Φ 0.8mm	5m

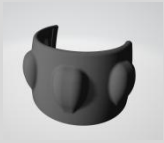
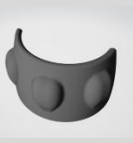
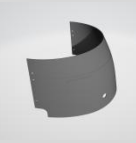
Hardware					
Item	Quantity	Item	Quantity	Item	Quantity
M3*10 Screw 	8	M3 Flange nuts 	2	Micro Copper hinge 	6
M3 Cylindrical nuts 	4	M1.2*4 Screw 	Ca.120	M3 Ø4 Plug 	8
M2*9 Screw 	70	M2*5 Screw 	20	M2 Screw nut 	45
M3 Screw nut 	12	Copper bushing 	2	Wheel holder 	2
M2*8 Screw 	14	M1.6*6 Screw 	10	M1.6 Screw nut 	10
Metal Buckle 	2	Push rod connector 	2	Aluminum buckles 	60
M4*15 Screw 	8	Plastic hinge 	9	M2 joint 	6
M2 L30MM stud 	4	M3 L60 stud 	4	M3 L30 stud 	8
Spring 	2	M3 mini magnet 	8	M1*3 Screw 	50

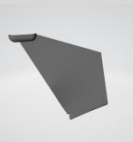
Hardware					
Item	Quantity	Item	Quantity	Item	Quantity
Tail wheel module 	1	3 inch wheel 	2	M2 L45MM stud 	2

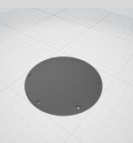
Plastic parts					
Item	Quantity	Item	Quantity	Item	Quantity
Cowl-bottom 	1	Cowl-top 	1	Top Cover 	1
Side Cover-Front 	2 (Left+Right)	Side Cover-Back 	2 (Left+Right)	Fuselage&Wing Fairing 	2 (Left+Right)
Muffler 	1	Wheel hub cover 	2		

Sheet parts	
1:1 drawing	2
Panel decals	1
Pu Leather Ca. 15*15cm	1
Laser cut PVC Sheet	1
0.3mm aluminum sheet 20*10cm	3

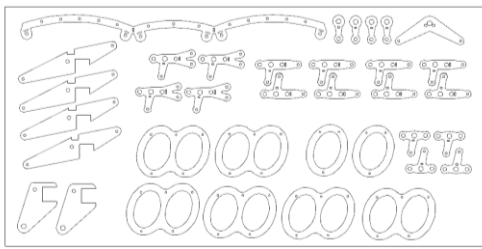
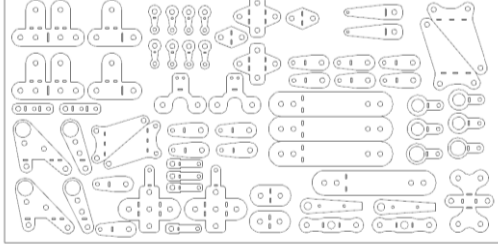
Laser cut Steel parts	
	

Metal tubes		
Item		Quantity
Tubes For Landing gear	Φ6 Steel tube. Length: ca.127mm. Φ2mm Hole at one end	2
	Φ4 Steel tube. Length: ca.150mm. Φ2mm Hole at both ends. Been bent	2
	Φ3 Aluminum tube. Length: ca.168mm.	2
	Φ4 Aluminum tube. Length: ca.100mm.	2
	Φ3 Aluminum tube. Length: ca.137mm.	1
Tubes For Struts	Φ4 Aluminum tube. Length: ca.145mm.	2
	Φ4 Aluminum tube. Length: ca.170mm.	2
	Φ4 Aluminum tube. Length: ca.131mm.	2
Wing Jigs	Outer Φ: 6mm, Inner Φ:4mm Aluminum Tube, Length:26cm	4



Part Location Lookup Form:

Part Number:	Wood Sheet Number:	Part Number:	Wood Sheet Number:
1. Fuselage		F4A	B1
S6	B1	B1	C2
S7	C1	FC1	Unmarked 1.0mm Soft Plywood
S7B	E1	FC2	Unmarked 1.0mm Soft Plywood
S7C	H1	FC4	Unmarked 1.0mm Soft Plywood
F4	D4	FC5	Unmarked 1.0mm Soft Plywood
T4	B1	FC6	F4
B2	B3	FC7	F4
B2A	B3	2.Tails	
F5	B1	V1	A10
F2A	B2	V1A	A9
T3	C3	V2	D3
F3	D4	V3	E2
S4	B2	V4	E2
S3	B1	V5	E2
F2	D2	V6	E2
S5	B1	V7	E2
T2	B2	V1A	E2
F1	B2	V1B	E2
F1A	B2	H6	D2
T1	D1	R3	D3
S1	E1	R8	A9
FR1	C2	R9	A9
FR1A	C2	R10	A10
FR1B	C2	R1	E1
FR1C	C2	R2	E1
FR2	C2	R11	A9
FR3	G1	R12	A8
F5B	F5	H1	D3
F6	C2	H2	A7
F7	C3	H4	E1
F8	C3	H5	E1
F9	C2	H2A	D3
F6B	A9	H2B	F4
F9A	D2	H3	D2, E1
F10	B3	E3	D3
S2	D1	E4	A7, A8
S2A	D1	E1	E1
B3	D1	E2	E1
F9B	C2	E5	E1

Part Location Lookup Form:

Part Number:	Wood Sheet Number:	Part Number:	Wood Sheet Number:
E6	E1	W5	C4
E7	E1	W6	C4
E8	E2	R1A	C4
E10	D2	J1	B3
E9	A4	J2	B3
3. Central wing		WC3	F2, F3
CR1	B3	WC4	F2, F3
CR1A	G1	WC5	F3
CR1B	C2	W3C	H1
CR2	D3	8. Top Wings	
CR3	D3	W1-TOP	A1, A3
CR4	C3	W2-TOP	A1, A3
WC1	F4	R1	C4
WC1UP	F4	Other wing ribs	A1~A9
Wooden wing struts	C3, C4	W3	C4
4. Cabin doors & panel		W7	A1, A2
HD1	G1	R0	A9
HD2	B3	AL7	B3
CK1	A11	AL4	G1
CK2	A11	R1A	C4
CK3	G1	J1	B3
CK4	G1	J2	B3
5. Landing gear		WC1	F1, F2
LD4	D3	WC5	F3
LD1	D3	9. Ailerons	
LD2	D3	AL1	Unmarked 1.0mm Soft Plywood
LD3	D3	AL2	A2, A4
LD5	D3	AL3	A4
LD6	D3	AL5	G1
7. Bottom wings		AL6	Unmarked 1.0mm Soft Plywood
W1	A1, A3	AL7	G1
W2	A1, A3	AL8	G1
R1	C4		
Other wing ribs	A1~A9		
W3B	C4		
W7	A1, A2		
R0	A9		
AL7	B3		
AL4	G1		
W4	C4		

1. ASSEMBLY-Fuselage

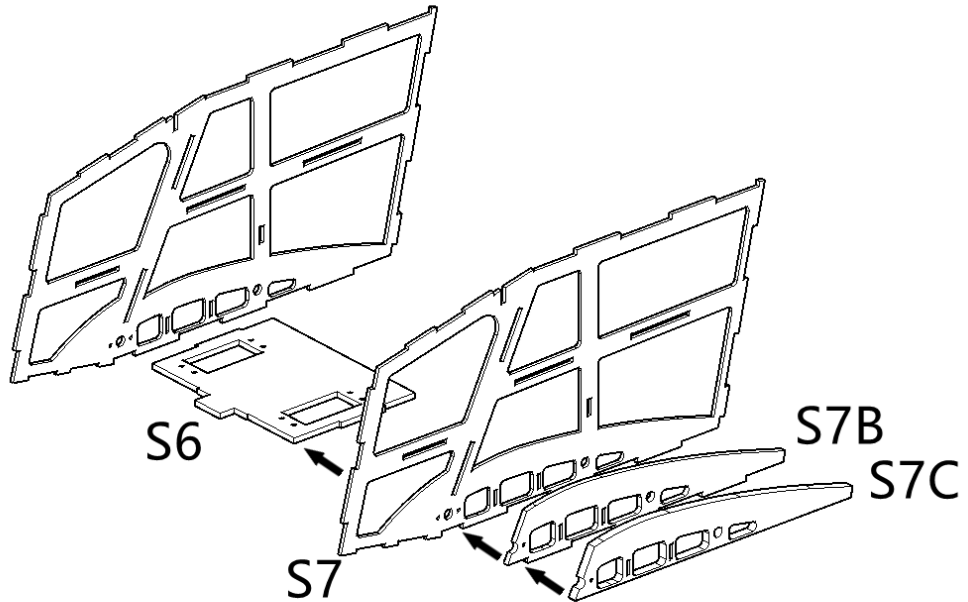

Step 1

Step 2

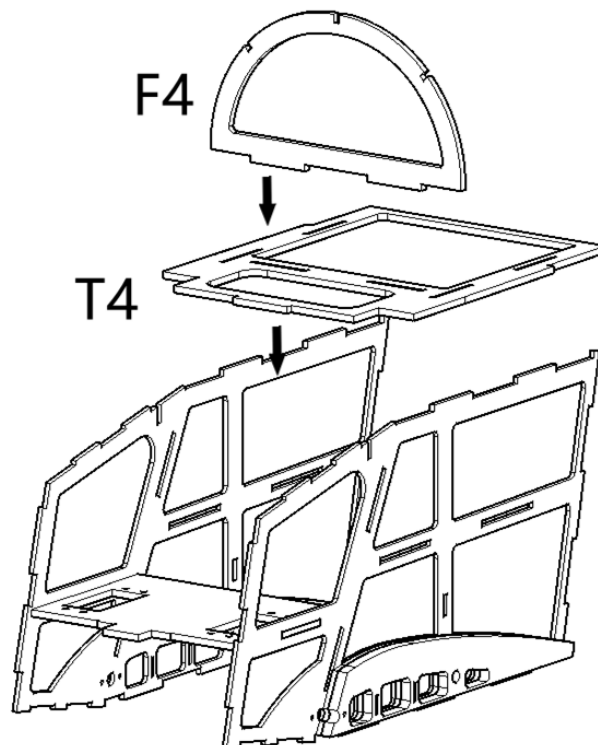

Step 3

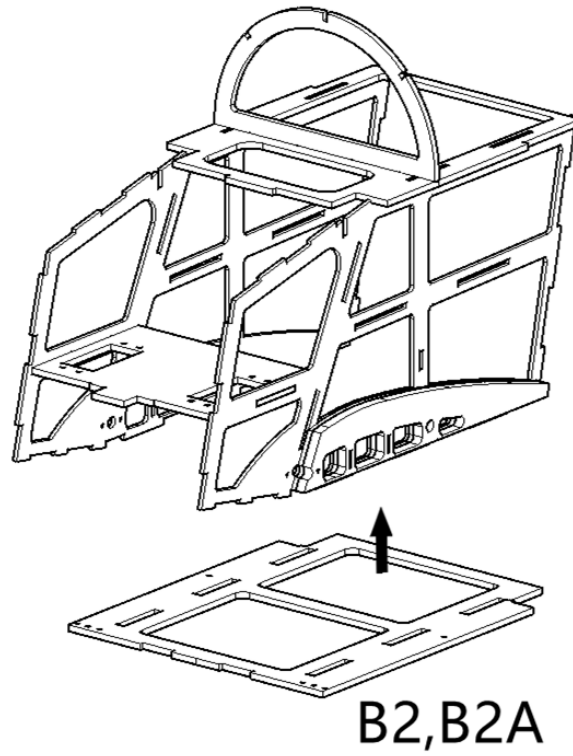

Step 4

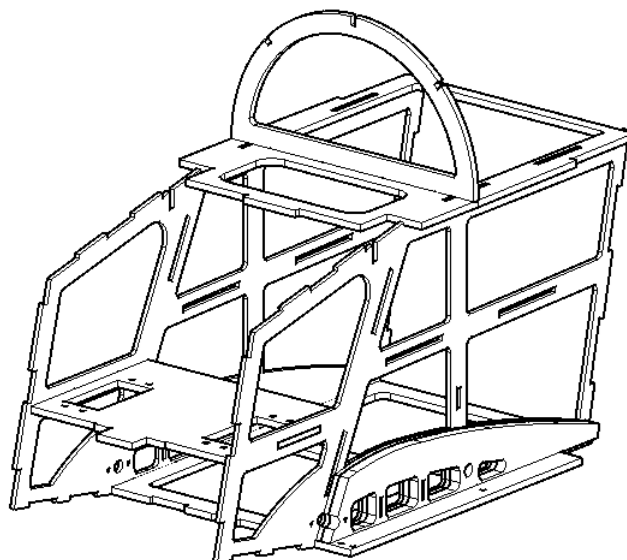

Step 5

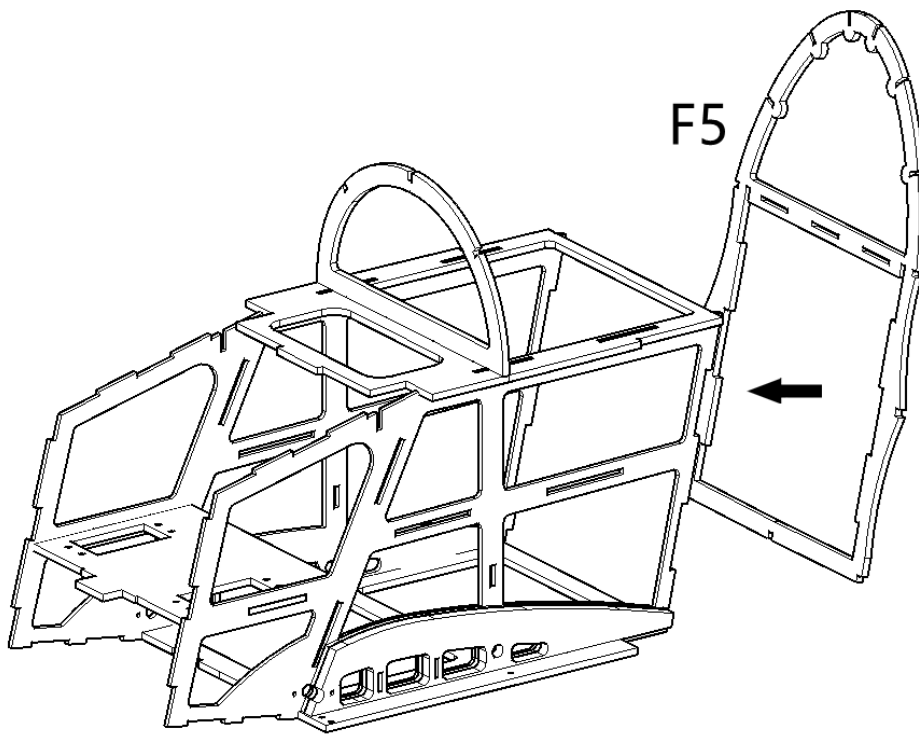

Step 6

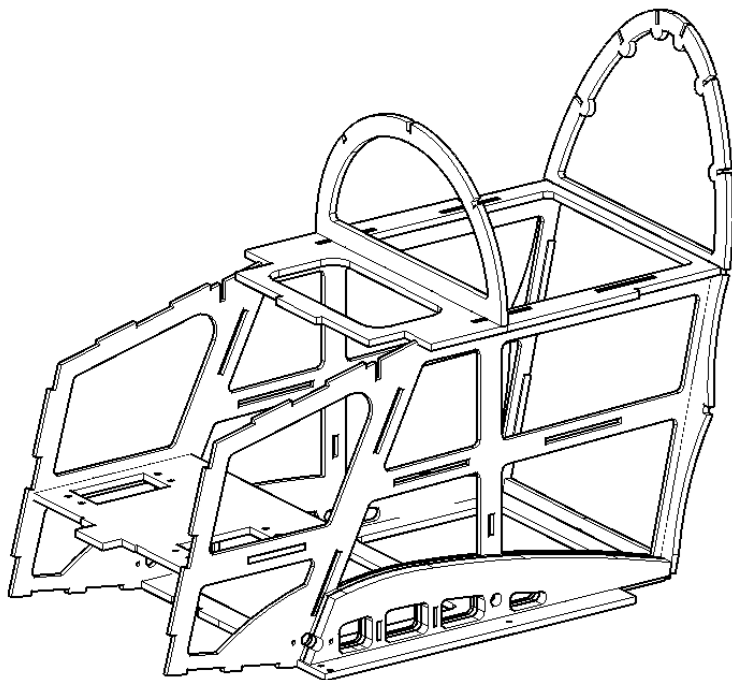

Step 7

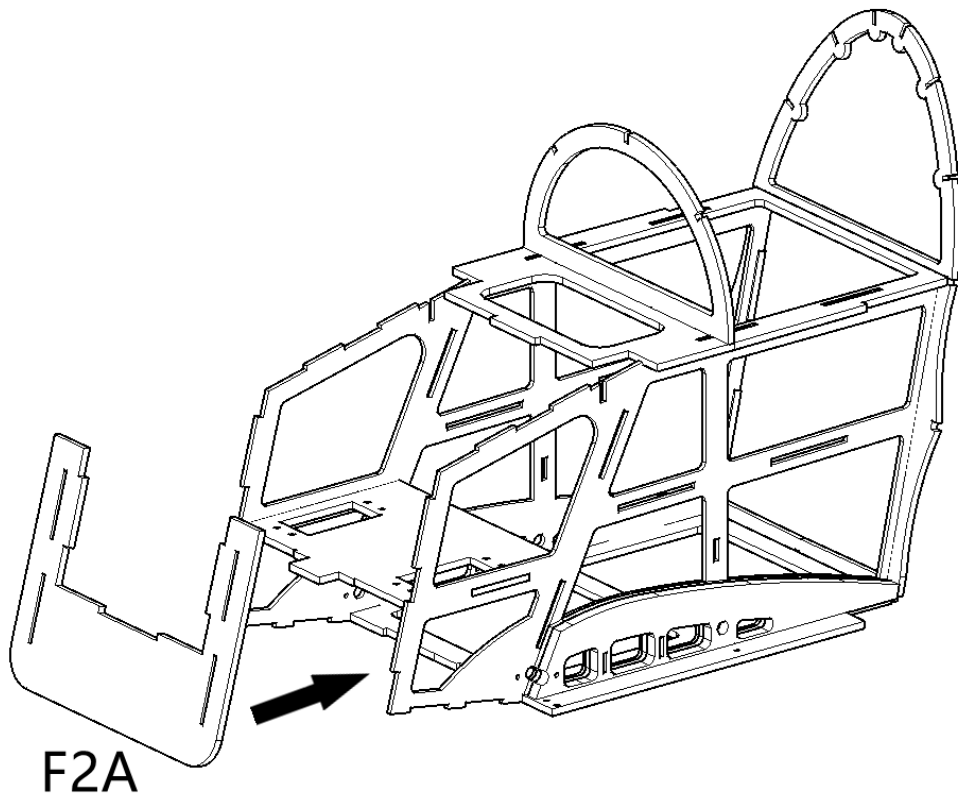

Step 8

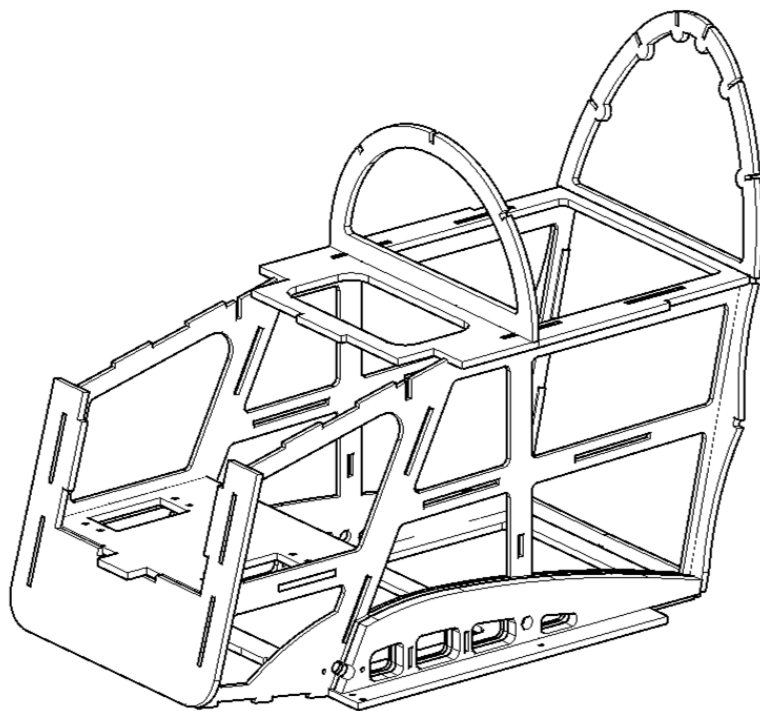

Step 9

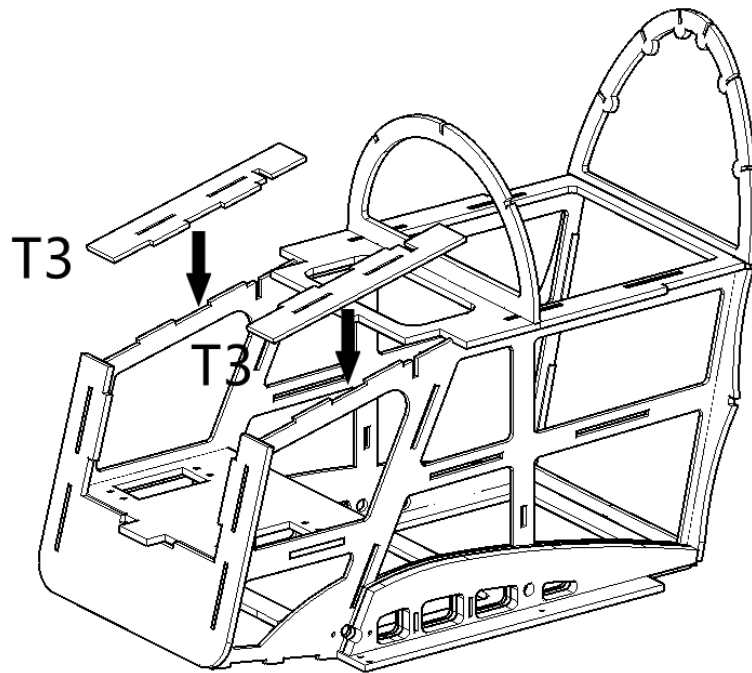

Step 10

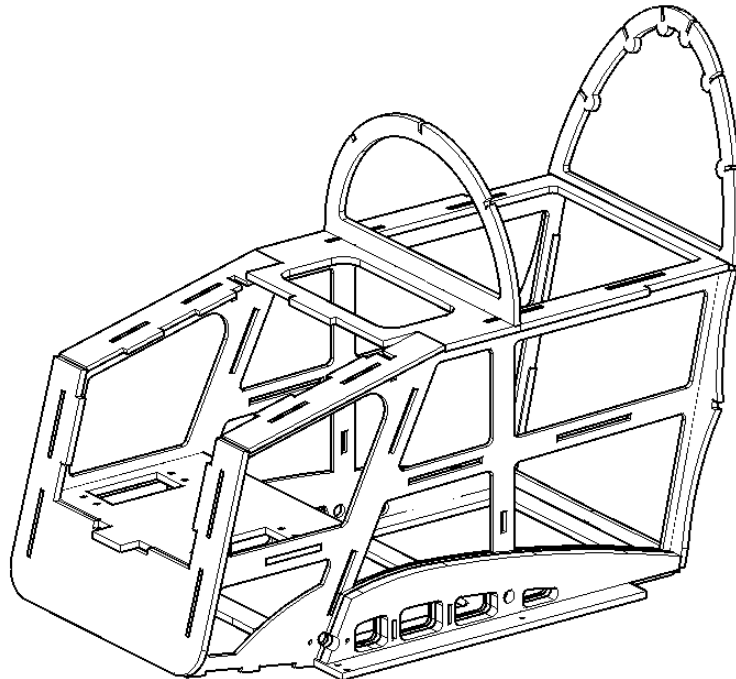

Step 11

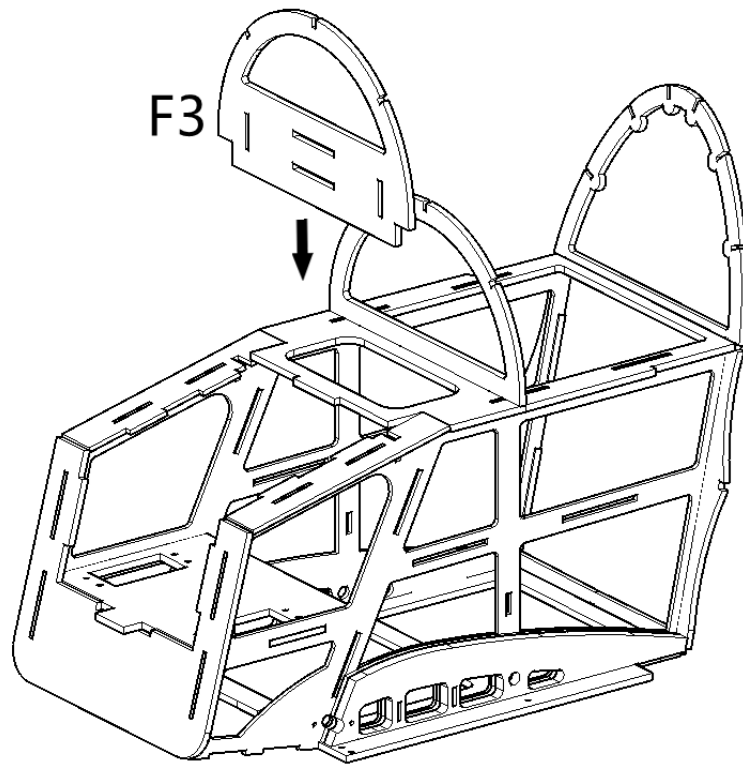

Step 12

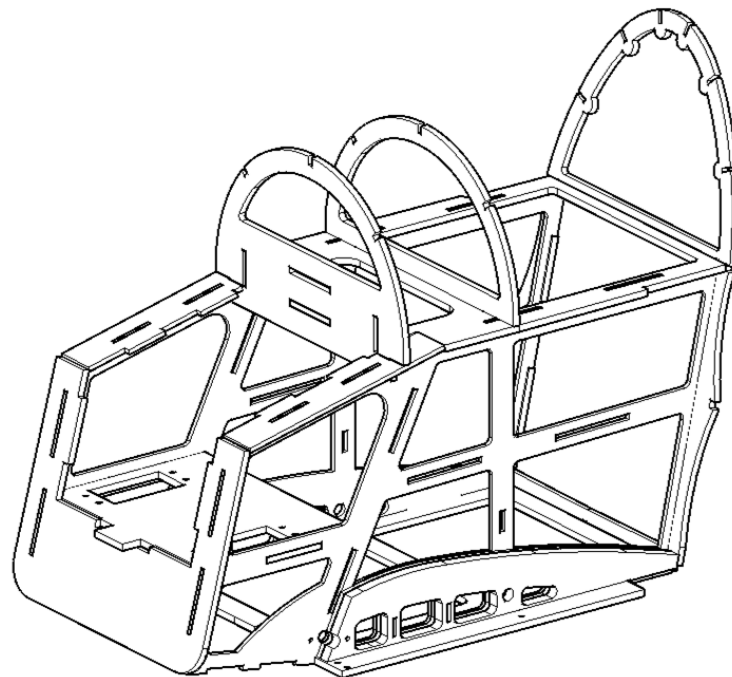

Step 13

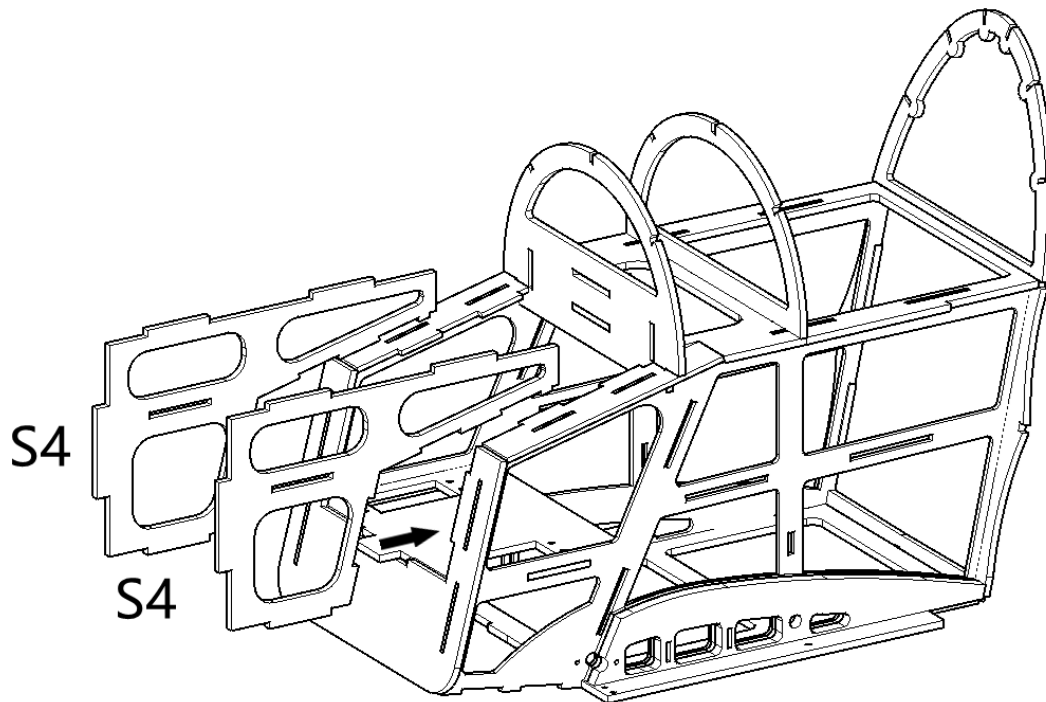

Step 14

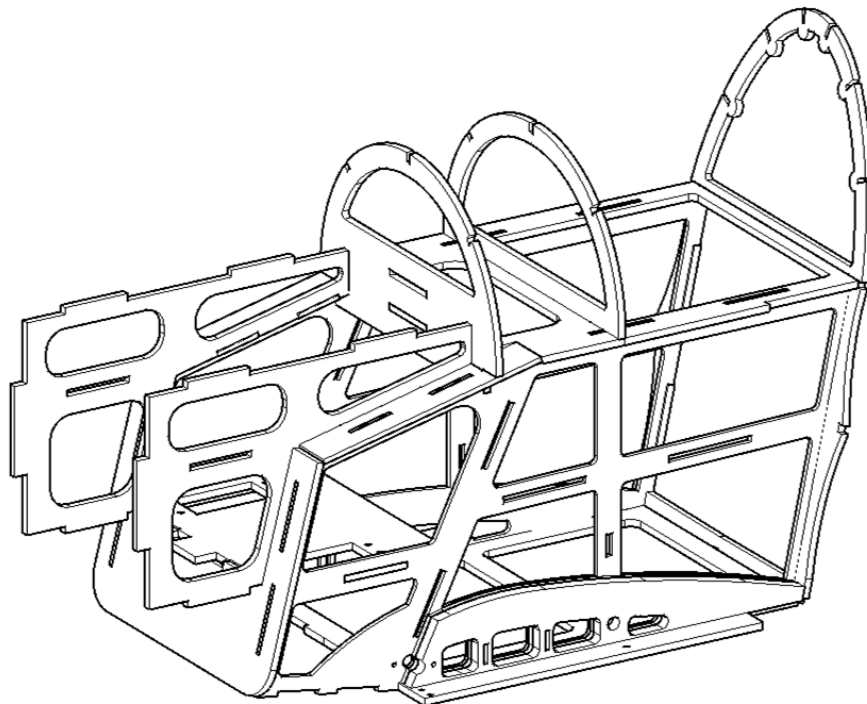

Step 15

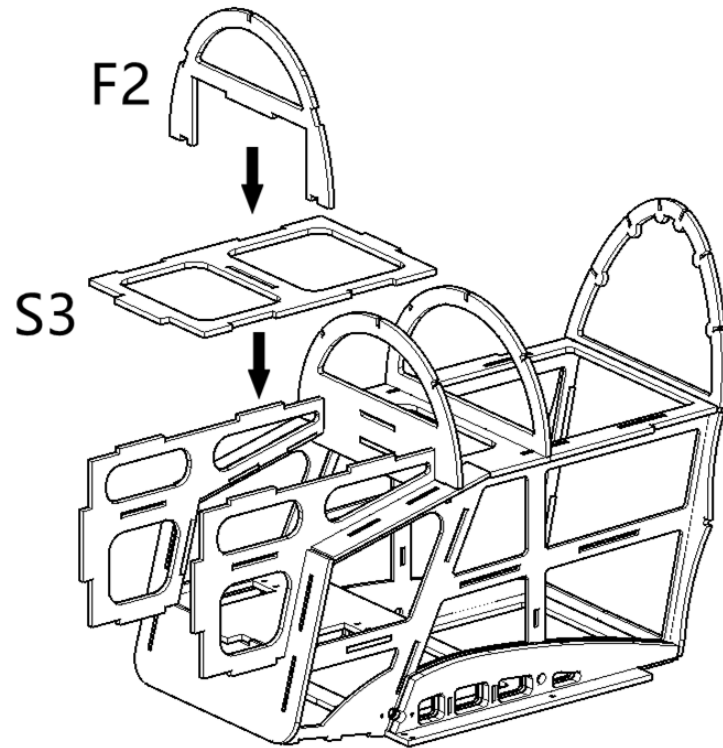

Step 16

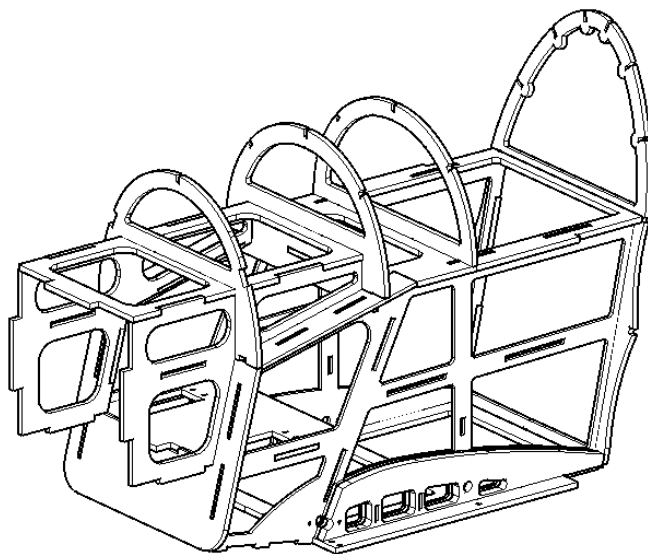

Step 17

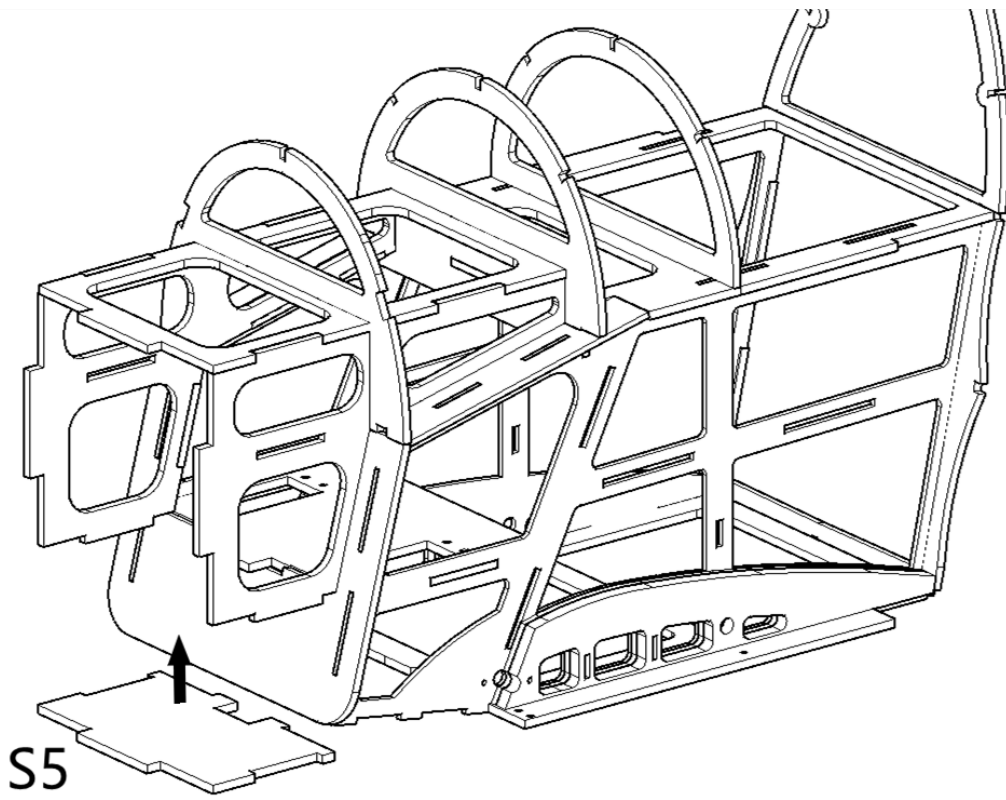

Step 18

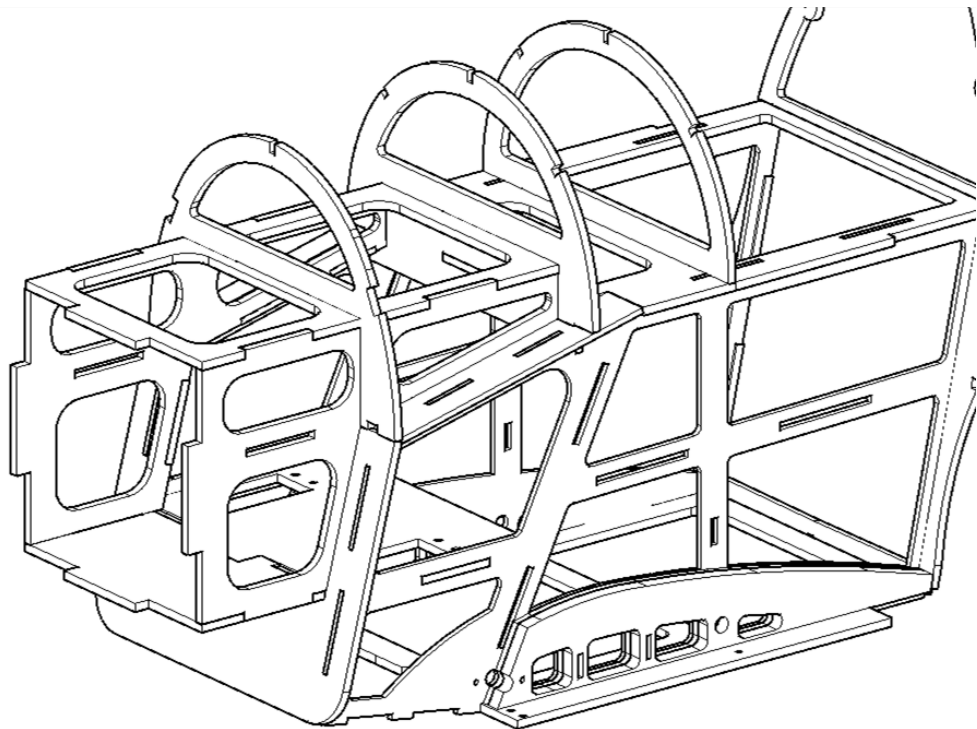

Step 19

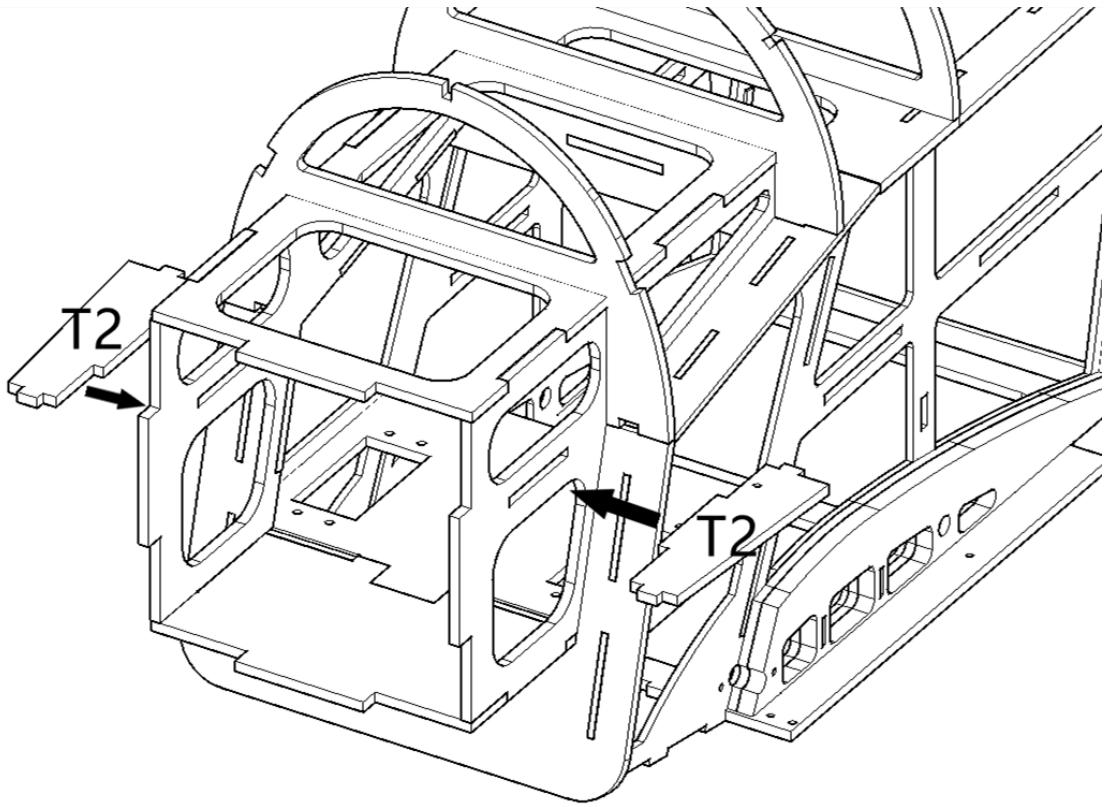

Step 20

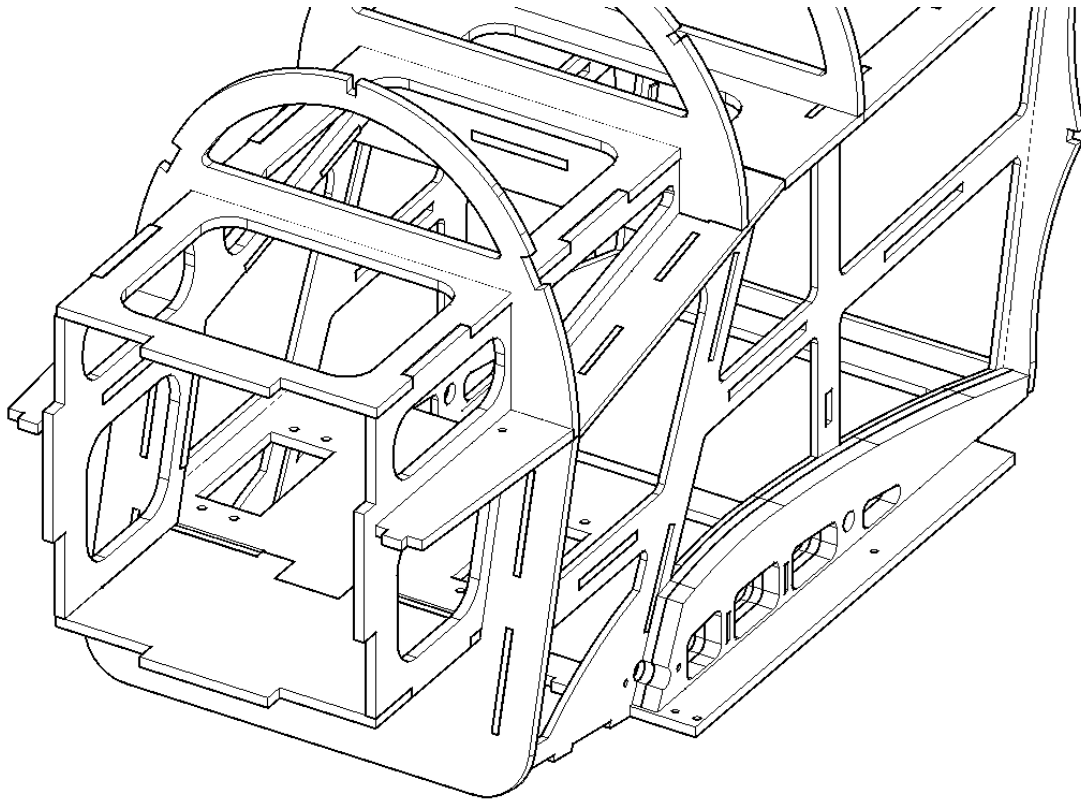

Step 21

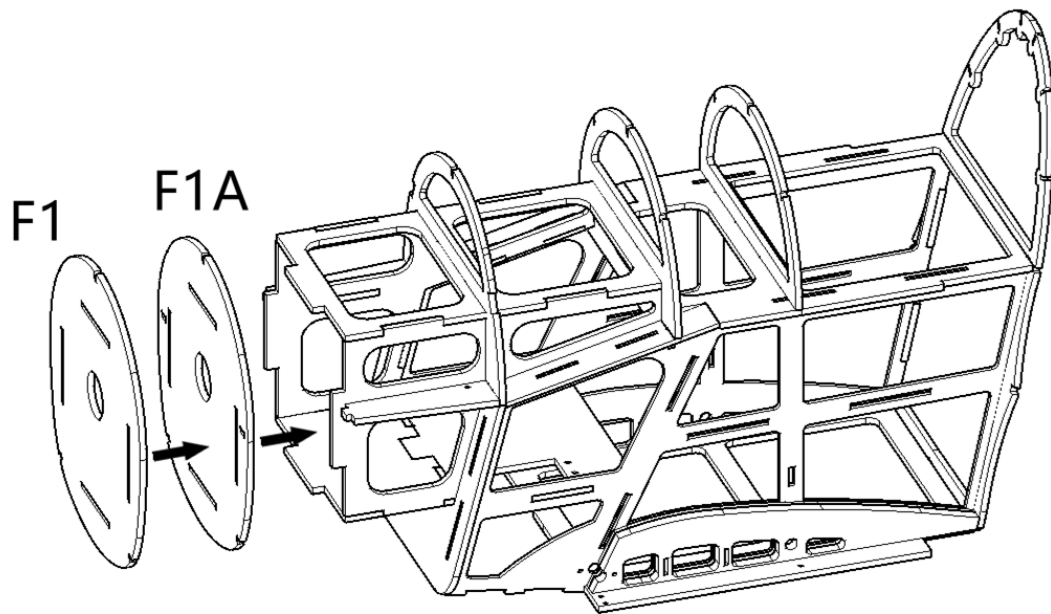

Step 22

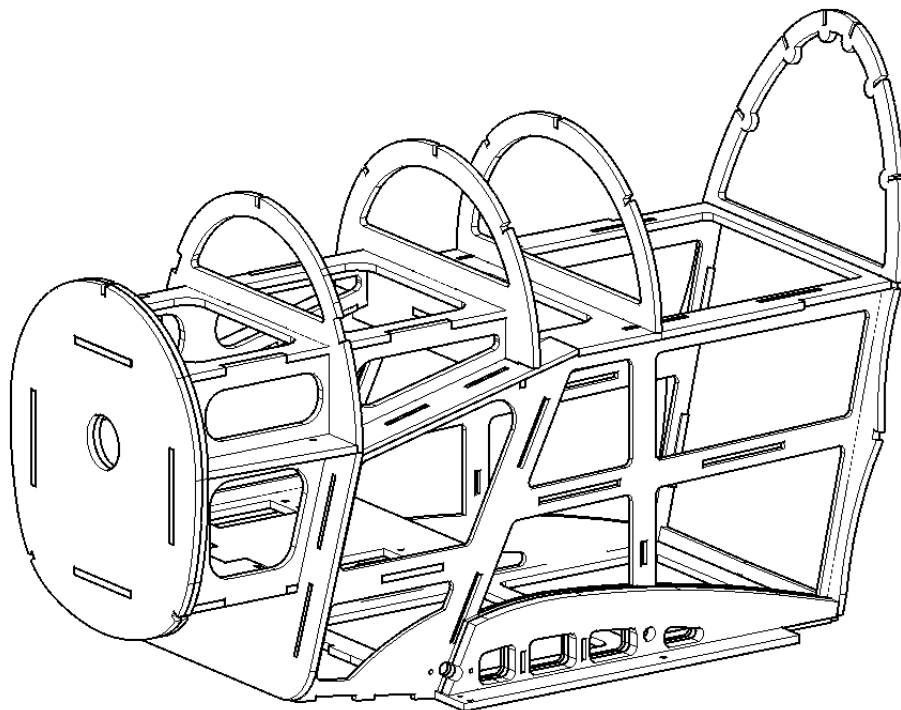

Step 23

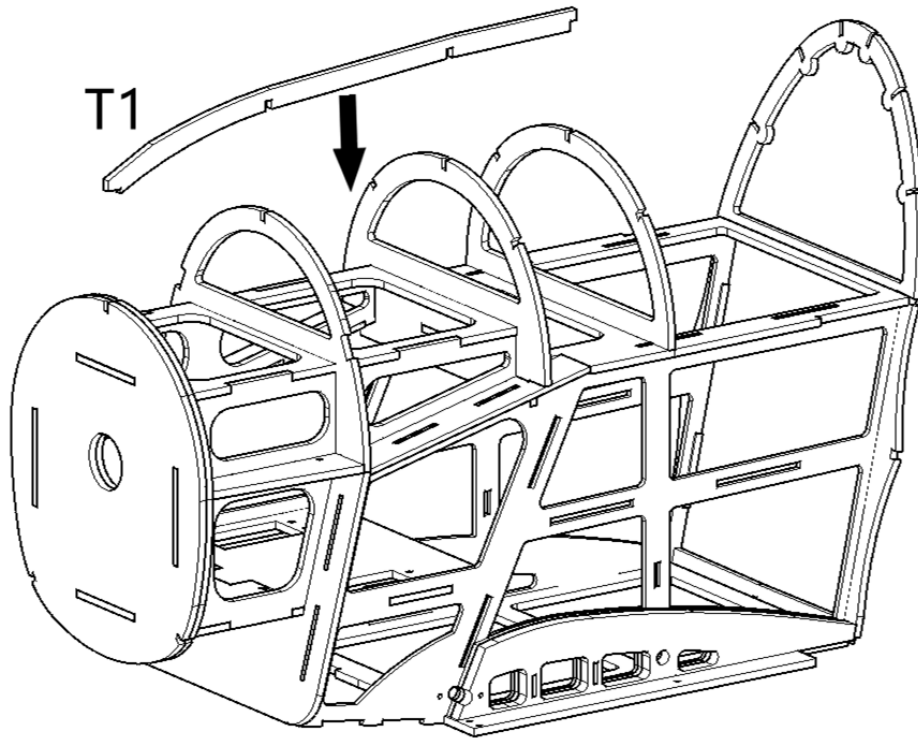

Step 24

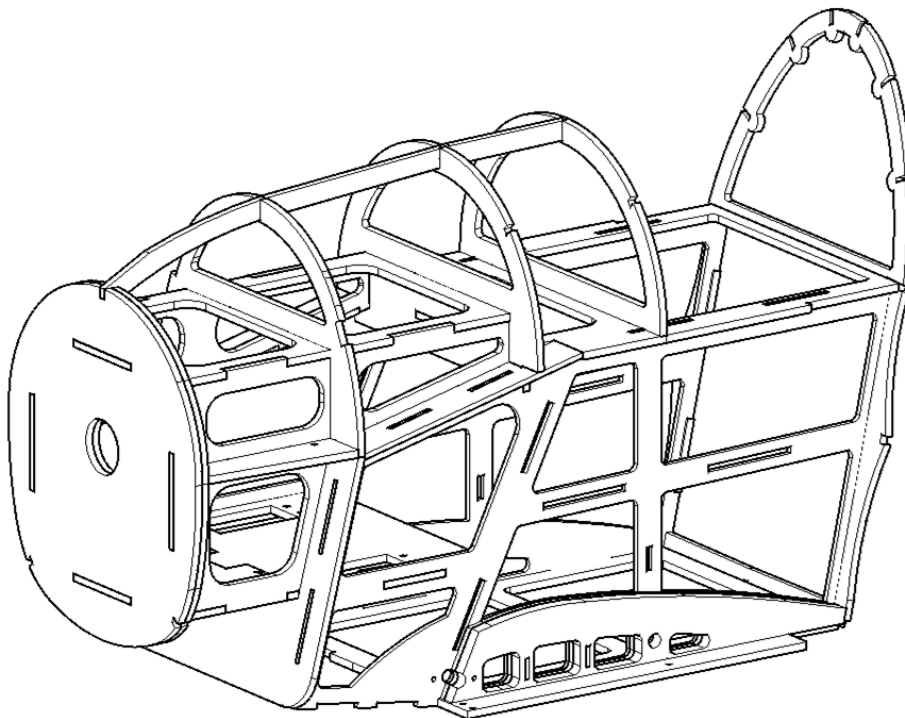

Step 25

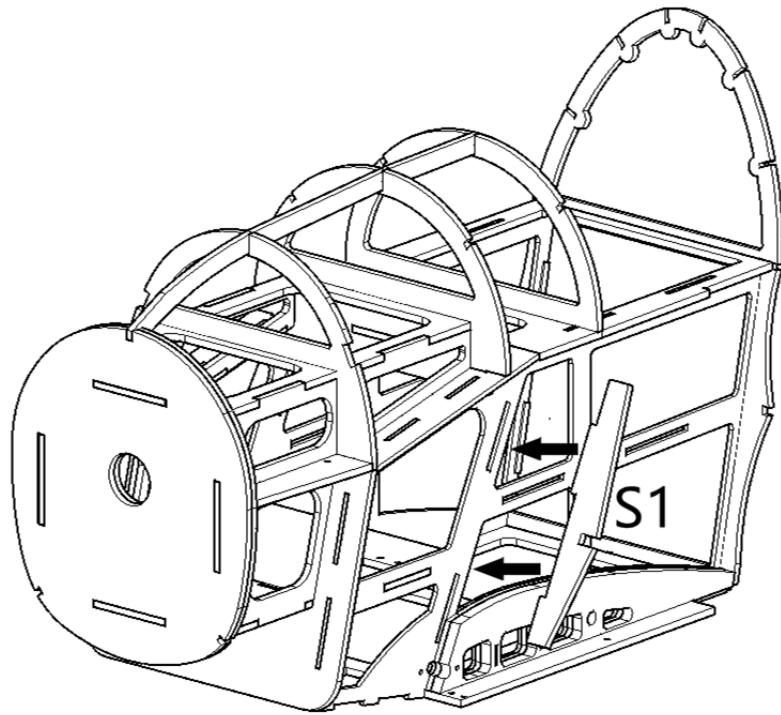

Step 26

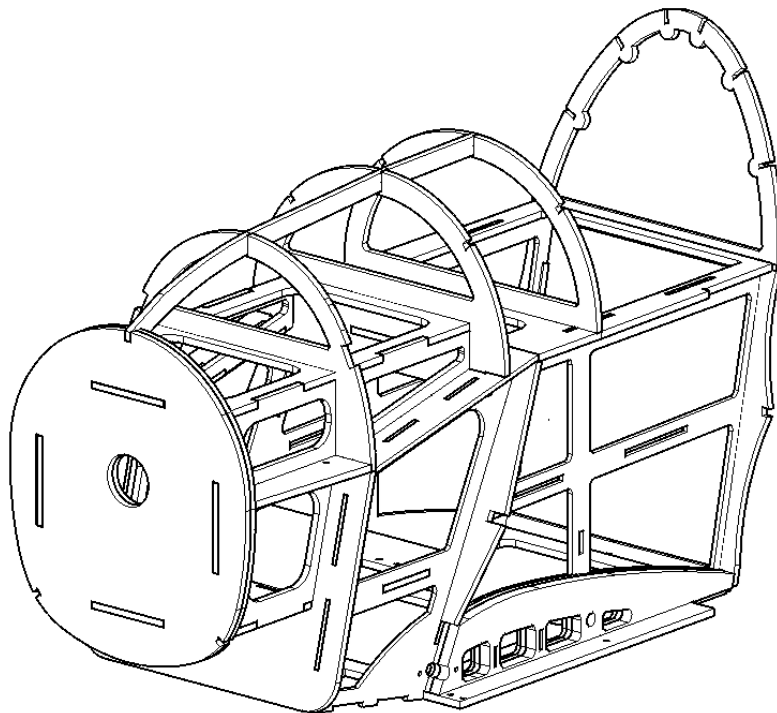

Step 27

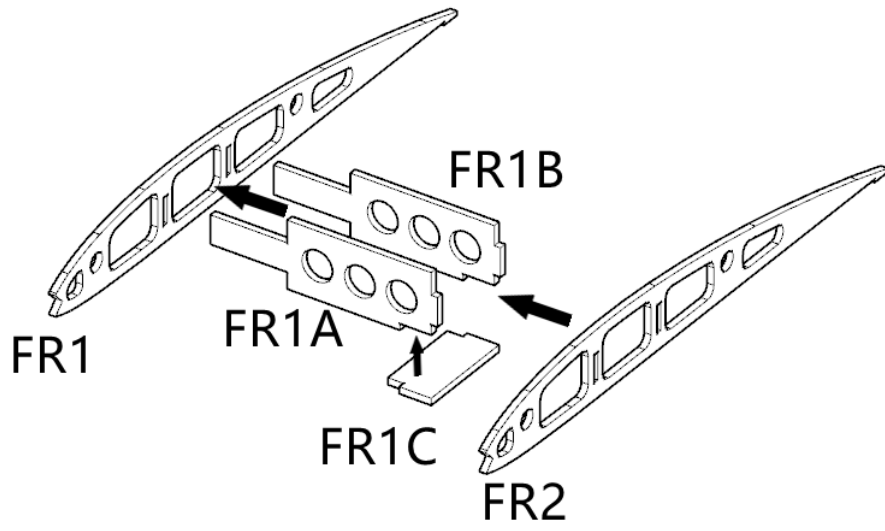

Step 28

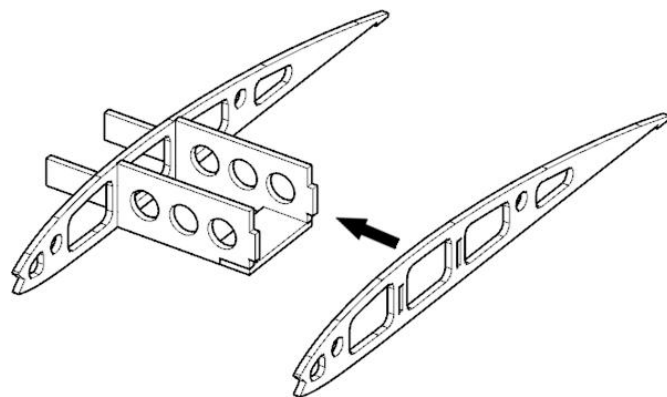

Step 29

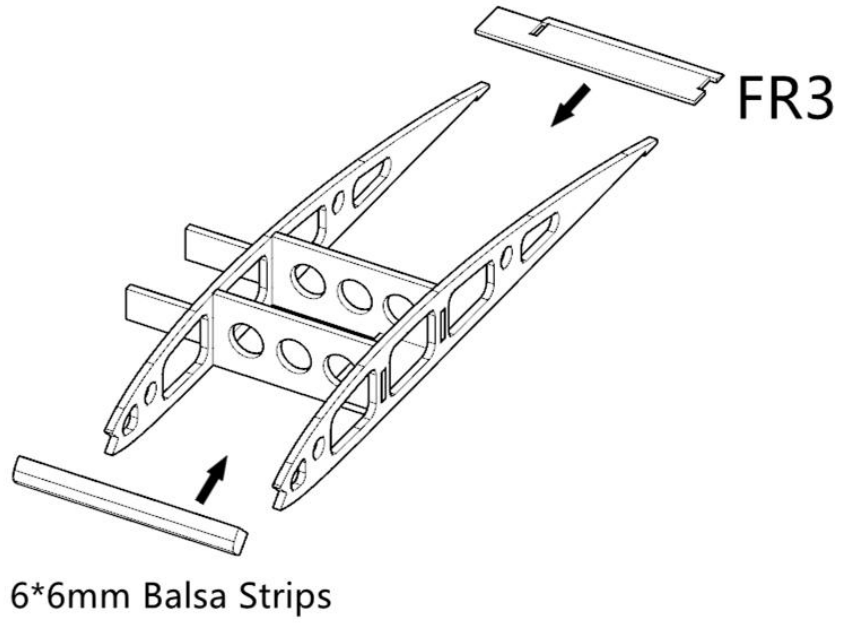

Step 30

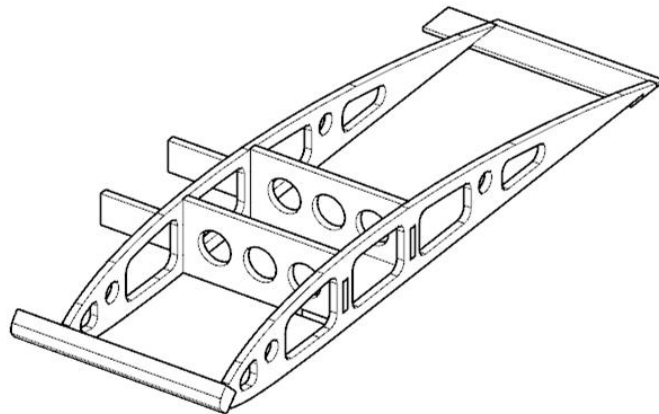

Step 31

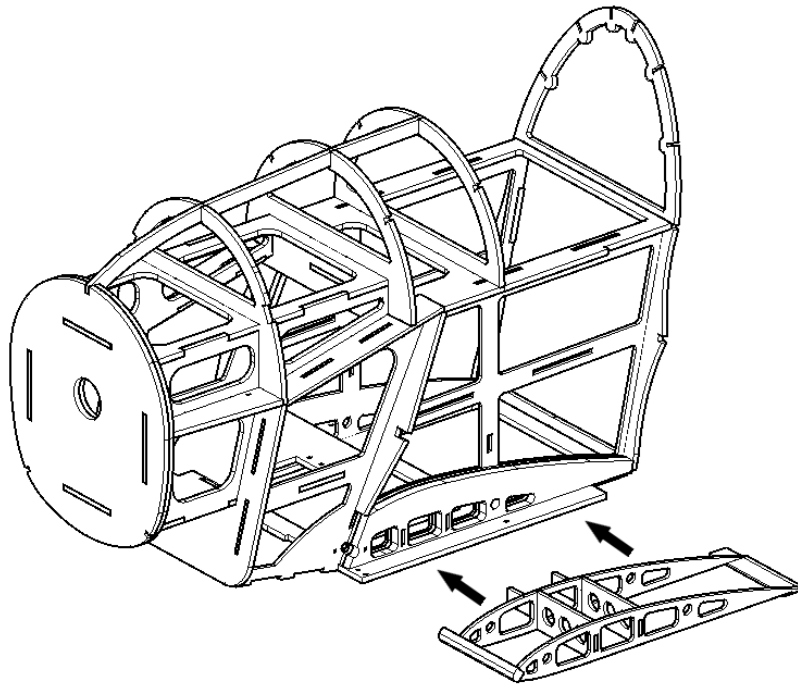

Step 32

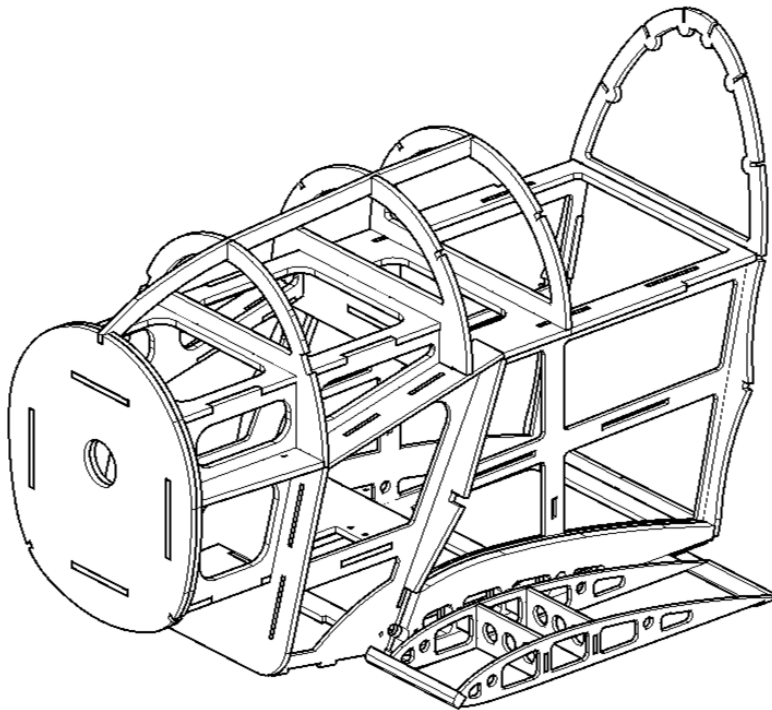

Step 33

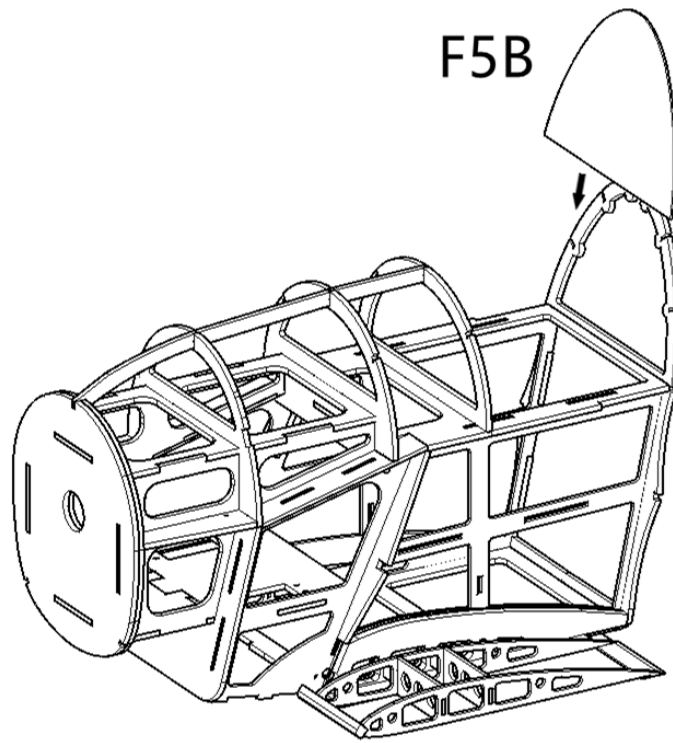

Step 34

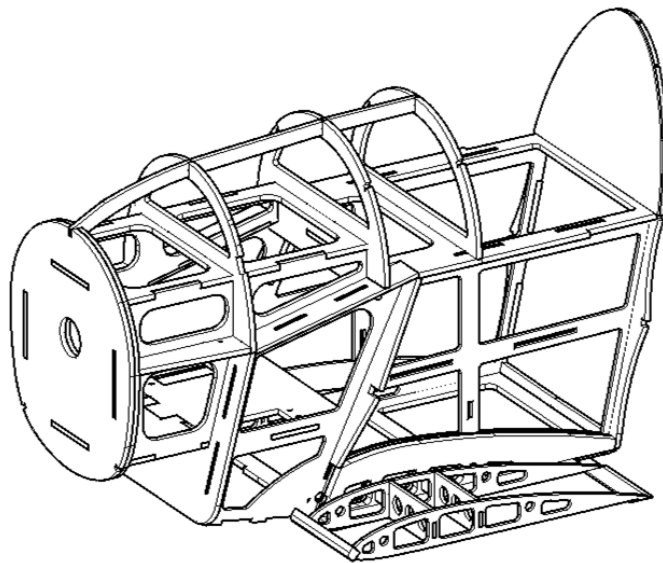

Step 35

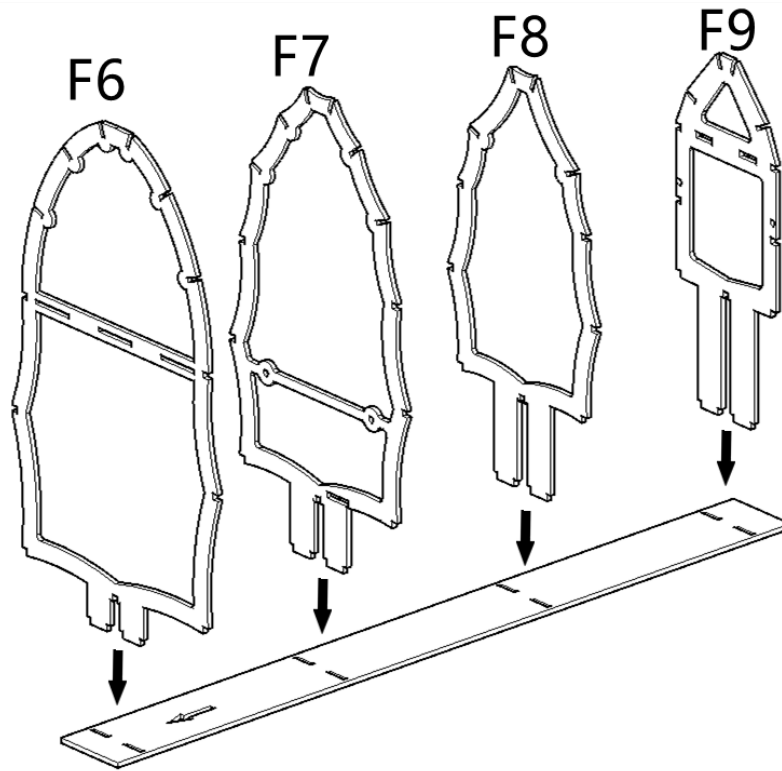

Step 36

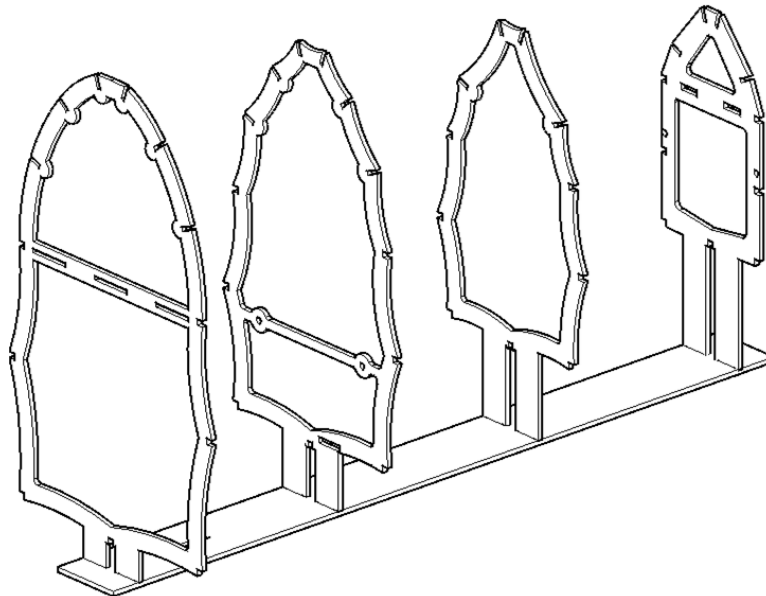

Step 37

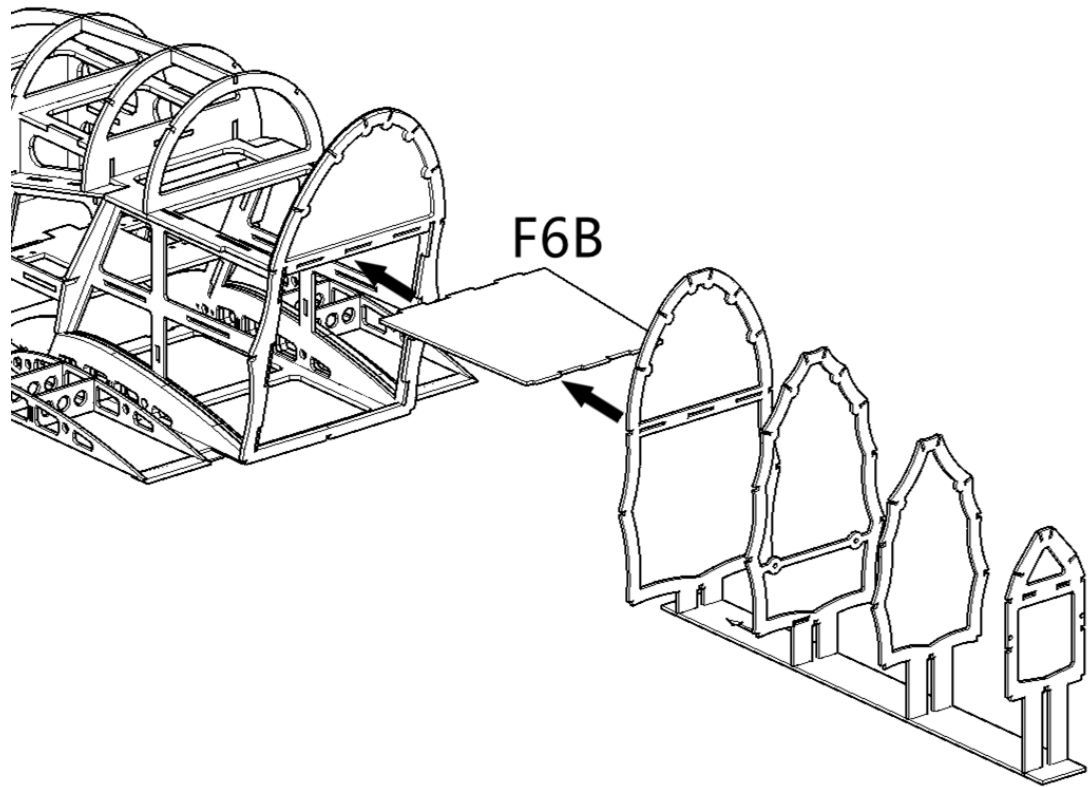

Step 38

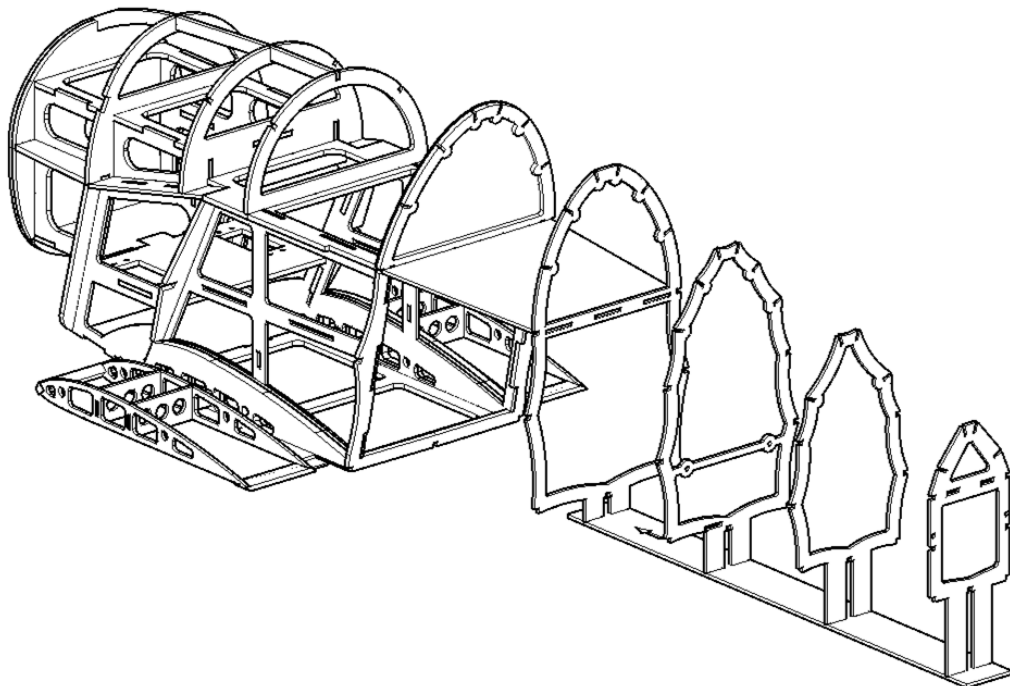

Step 39

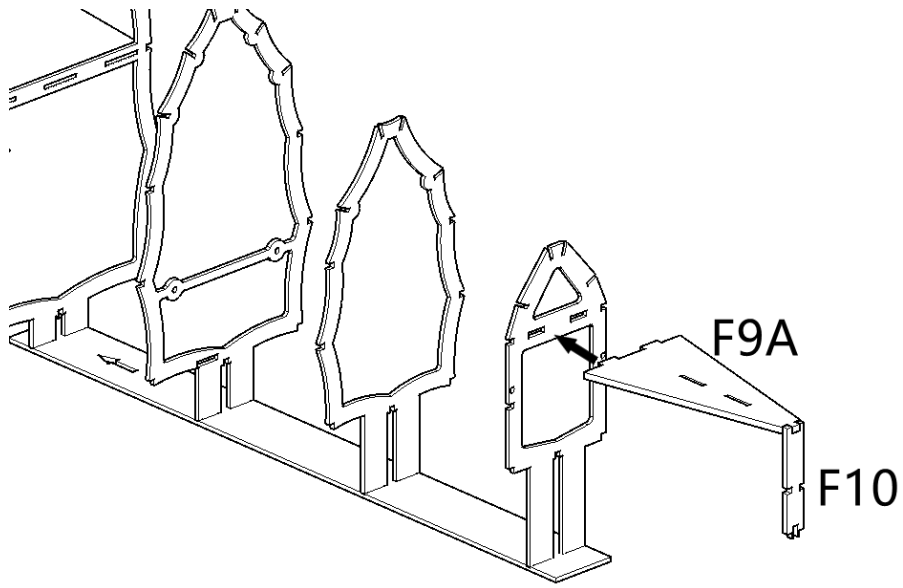

Step 40

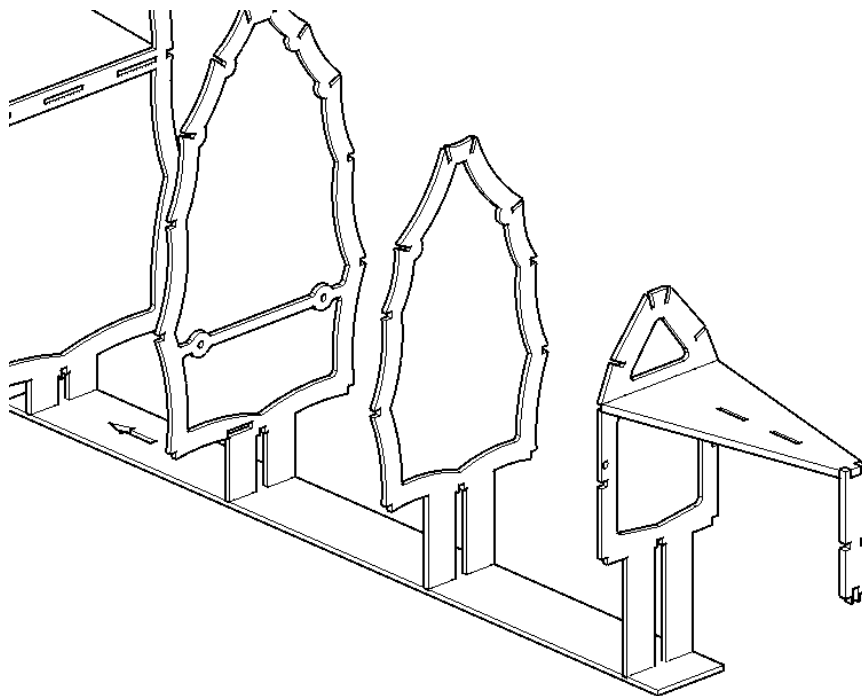

Step 41

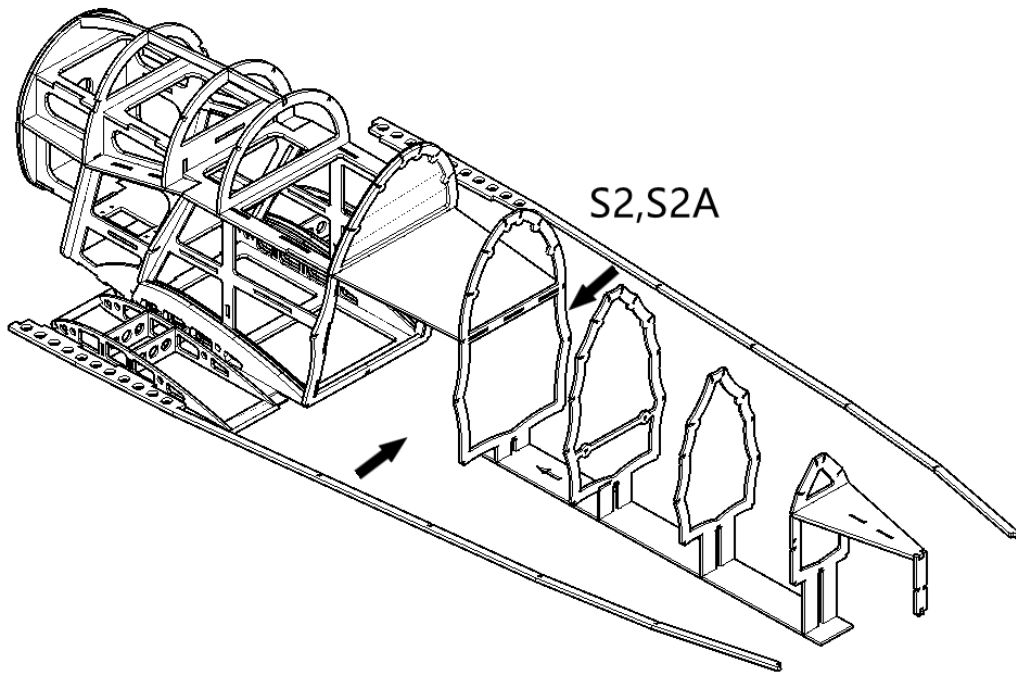

Step 42

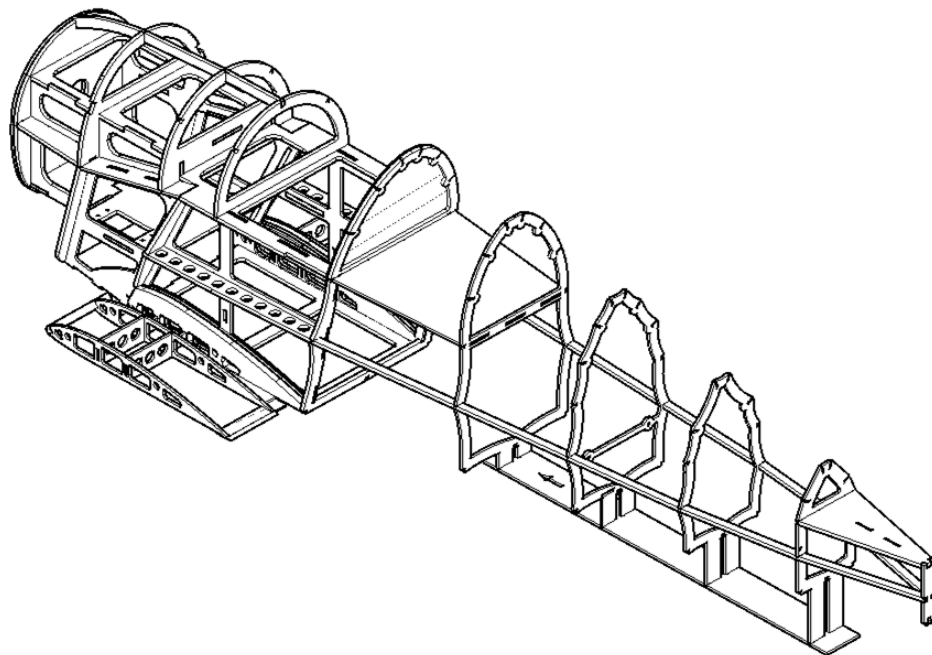

Step 43

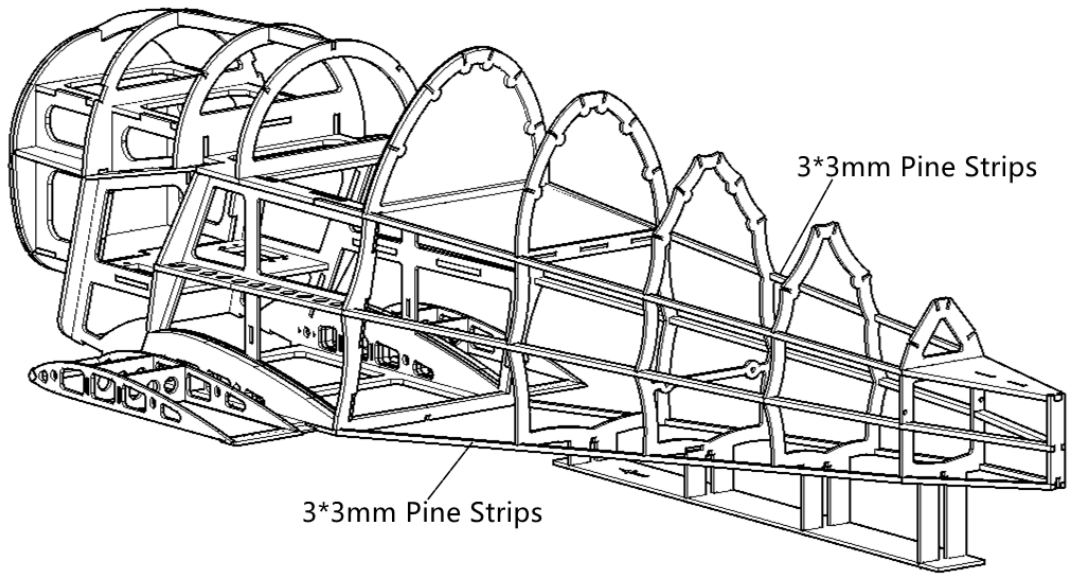

Step 44

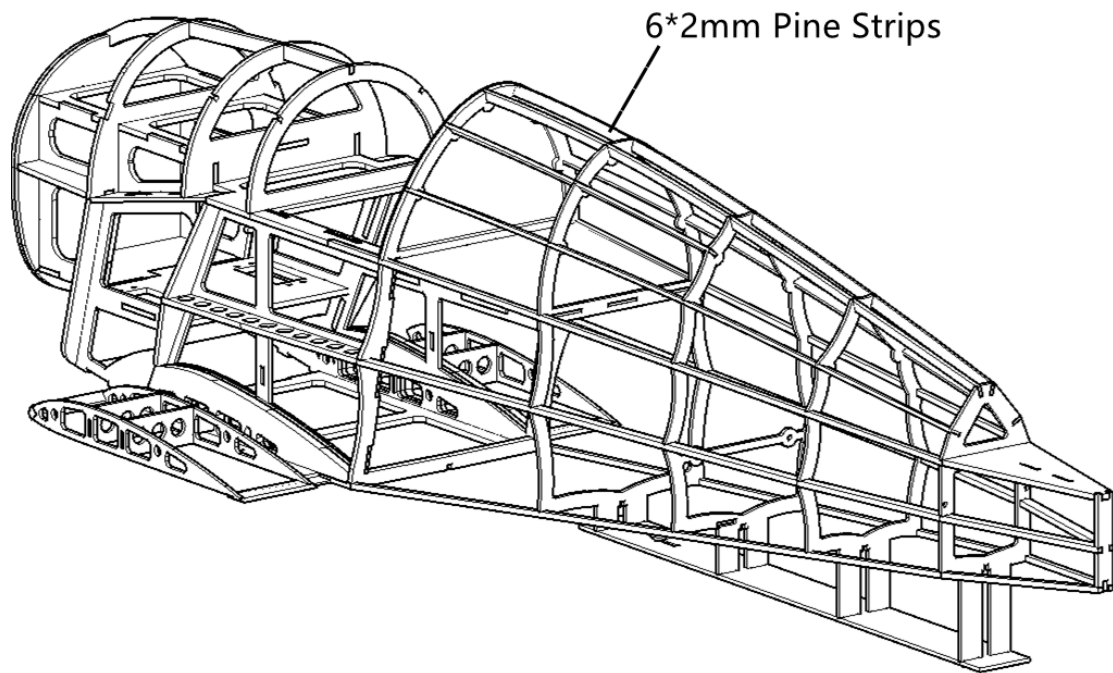

Step 45

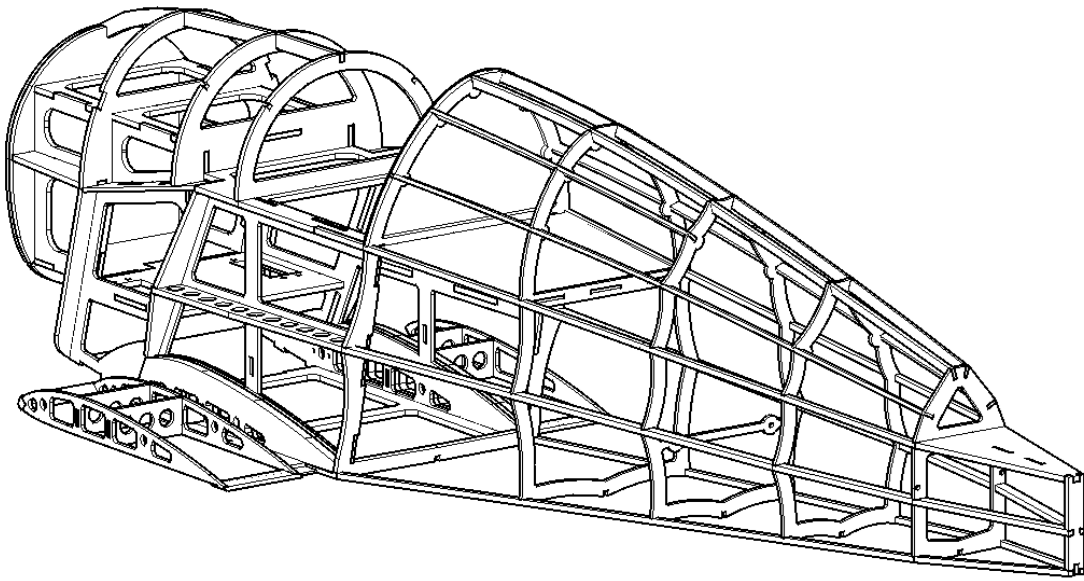

Step 46

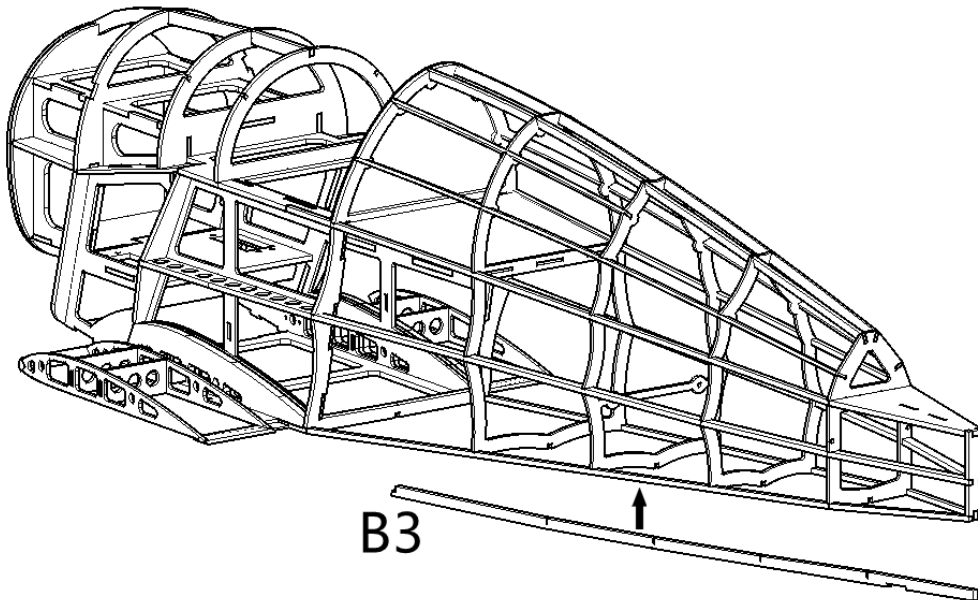

Step 47

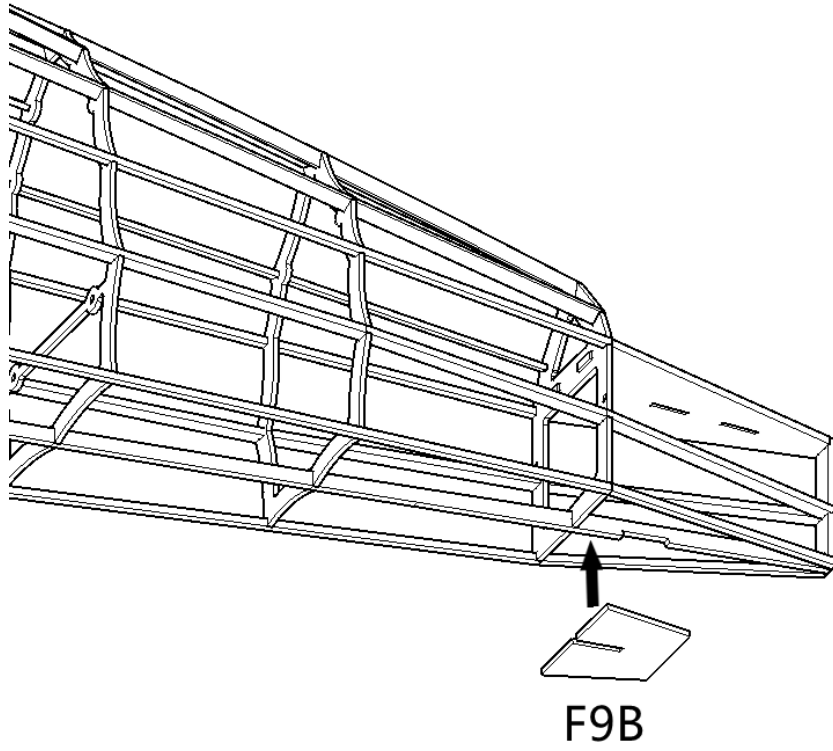

Step 48

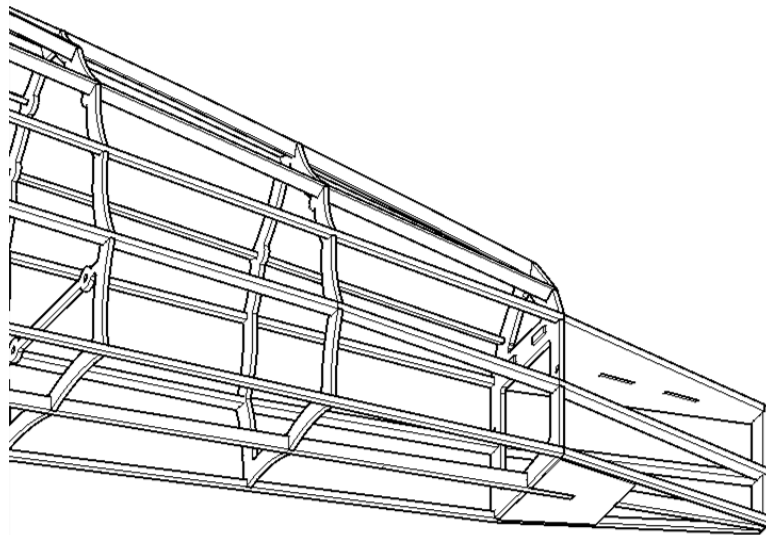

Step 49

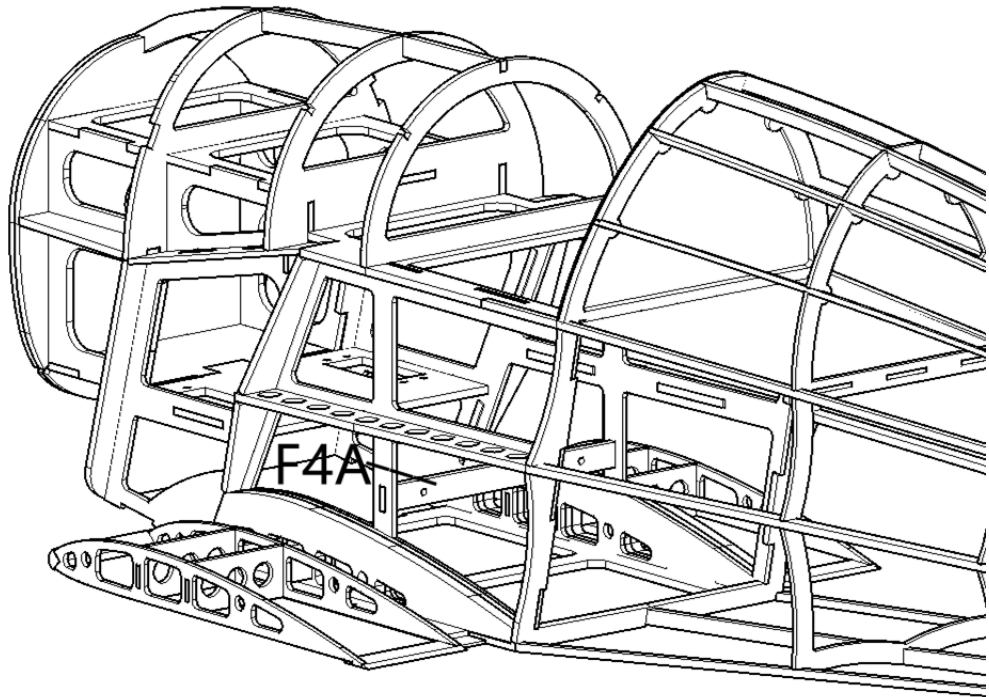

Step 50

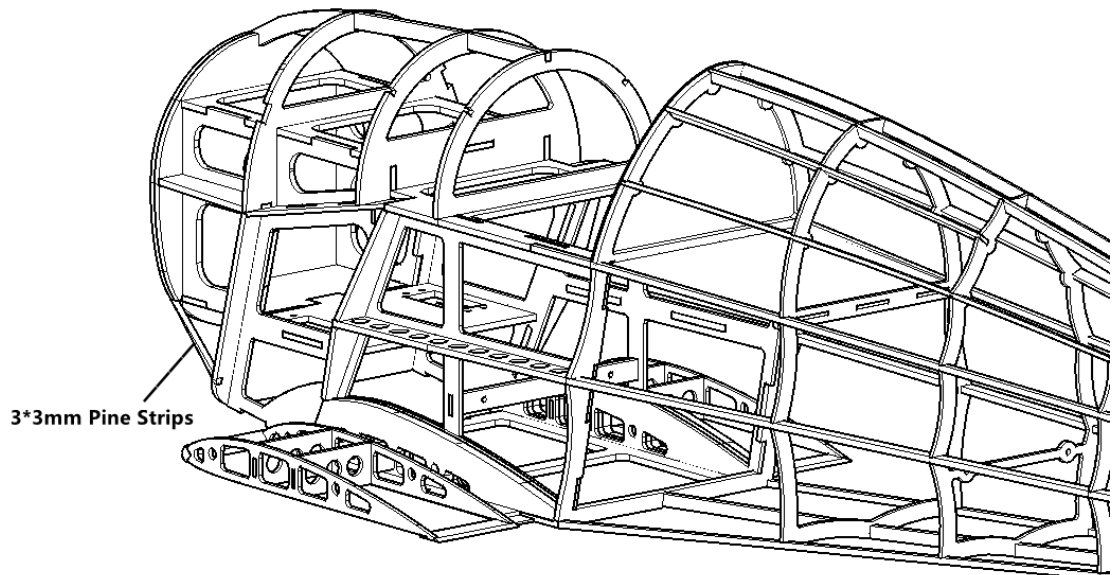

Step 51

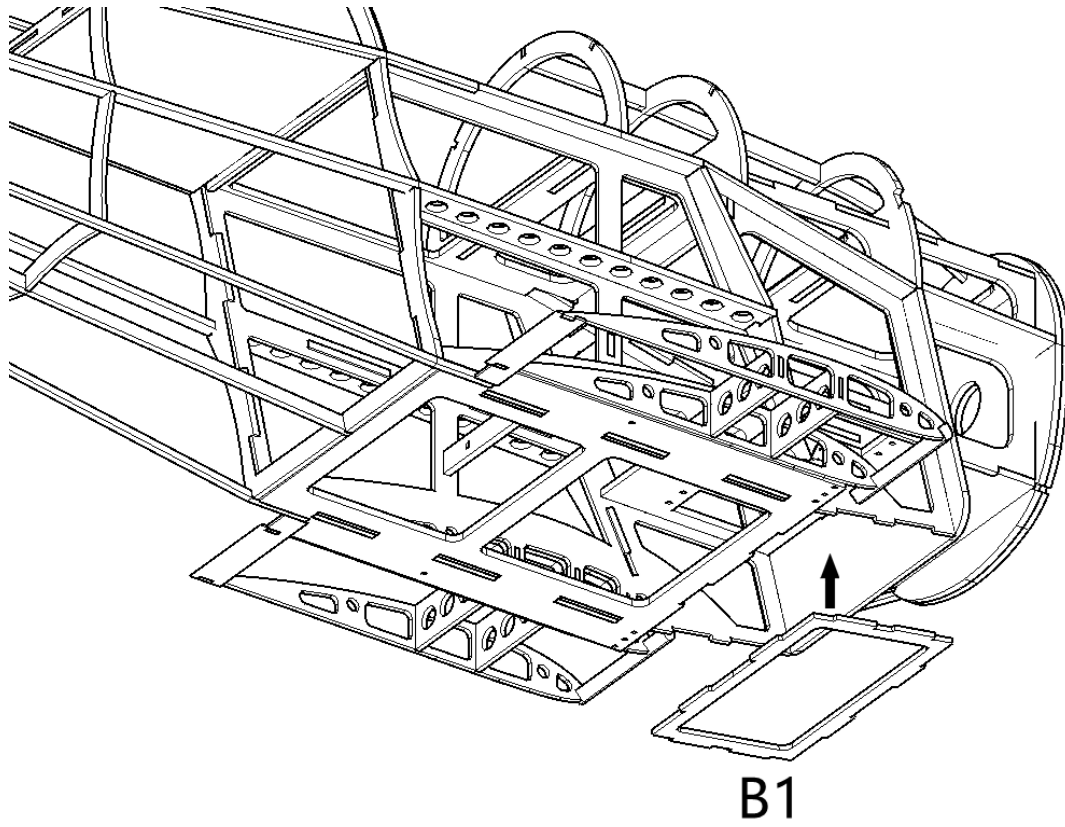

Step 52

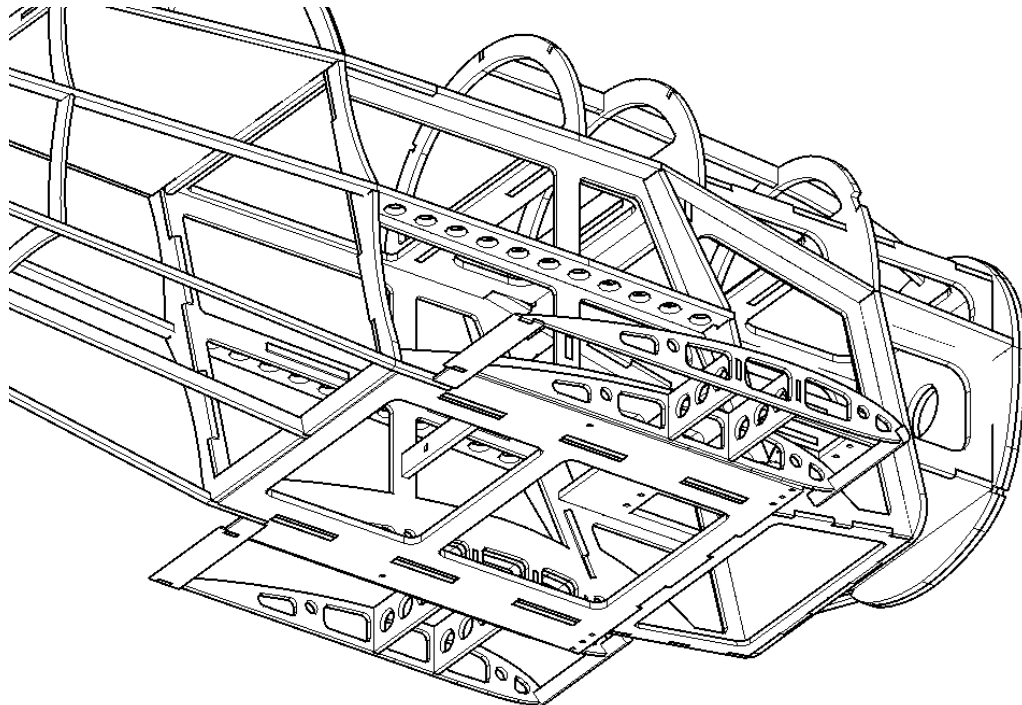

Step 53

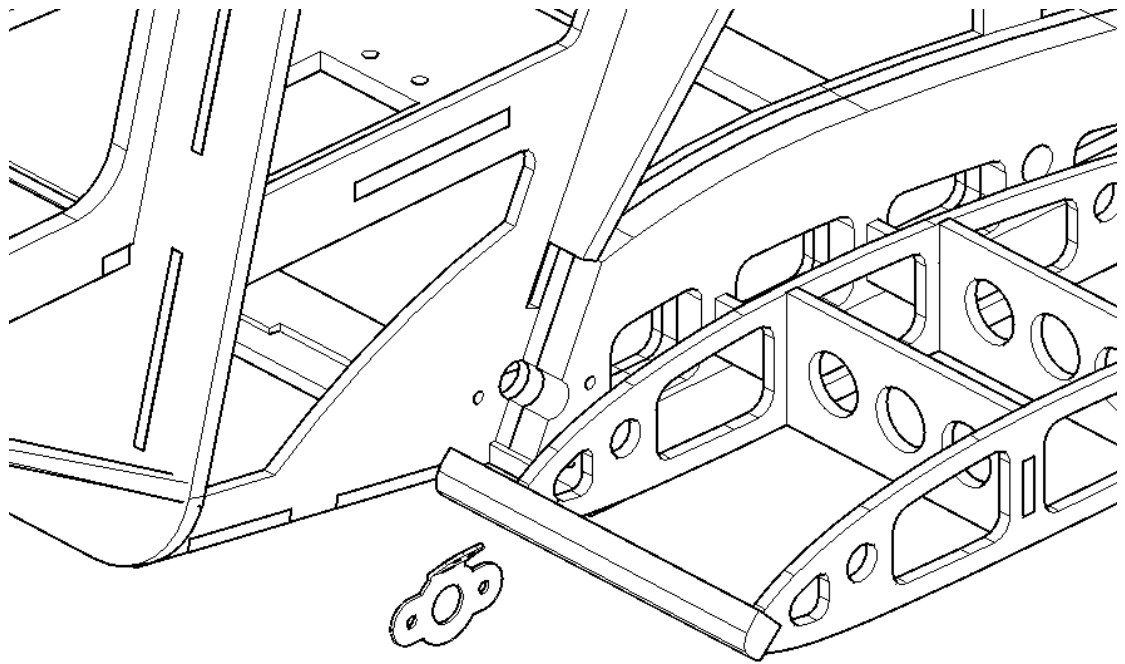

Step 54

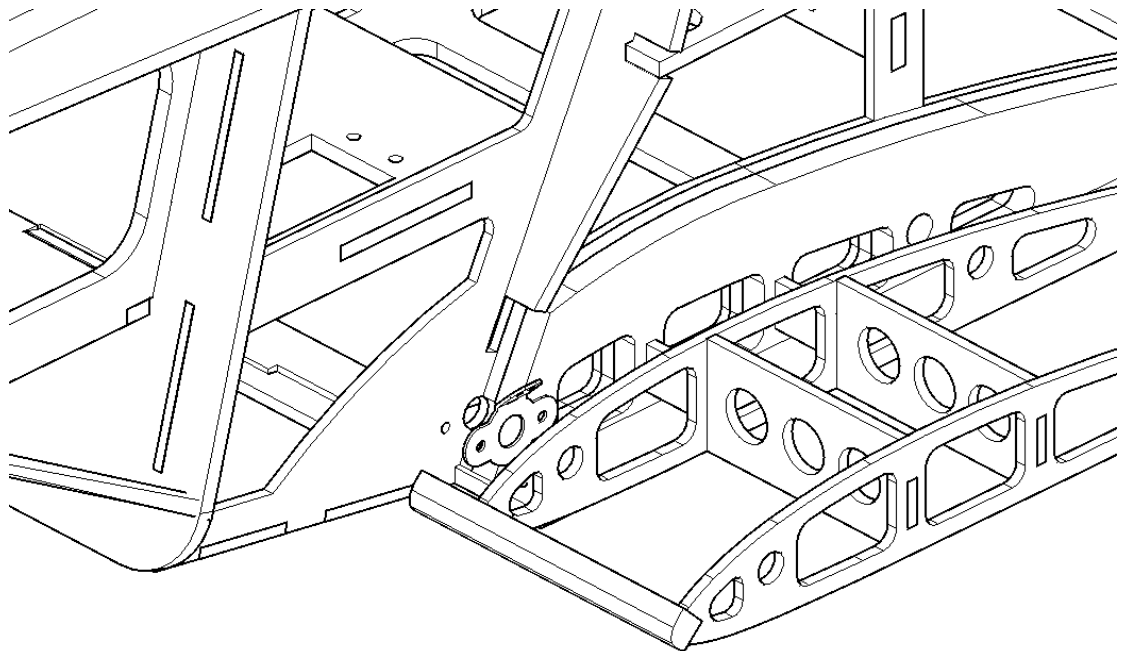

Step 55

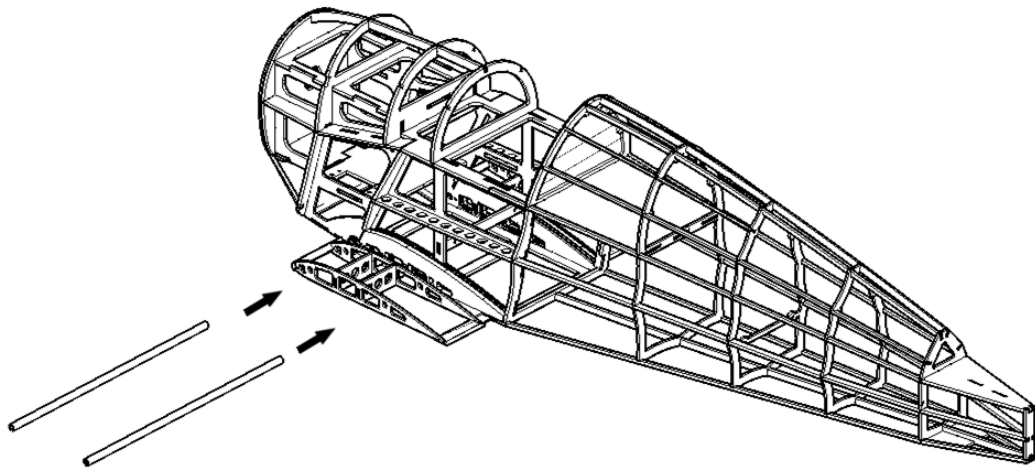

Aluminum Tube
(Outer Φ : 6mm, Inner Φ : 4mm)

Step 56

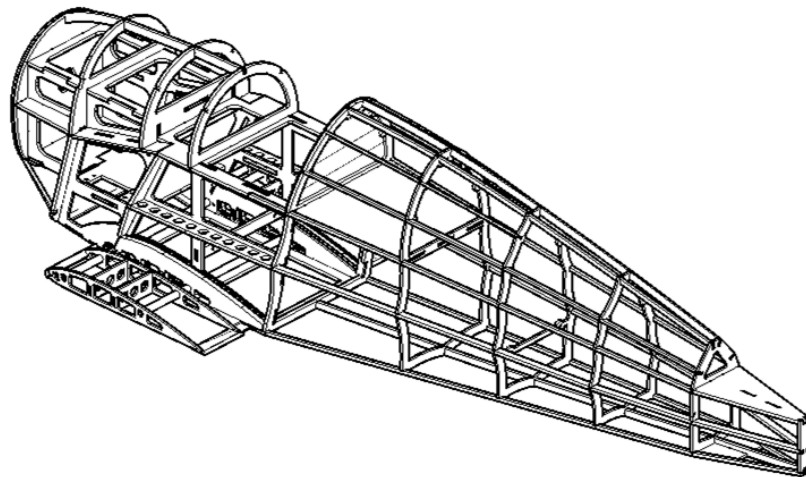

Step 57

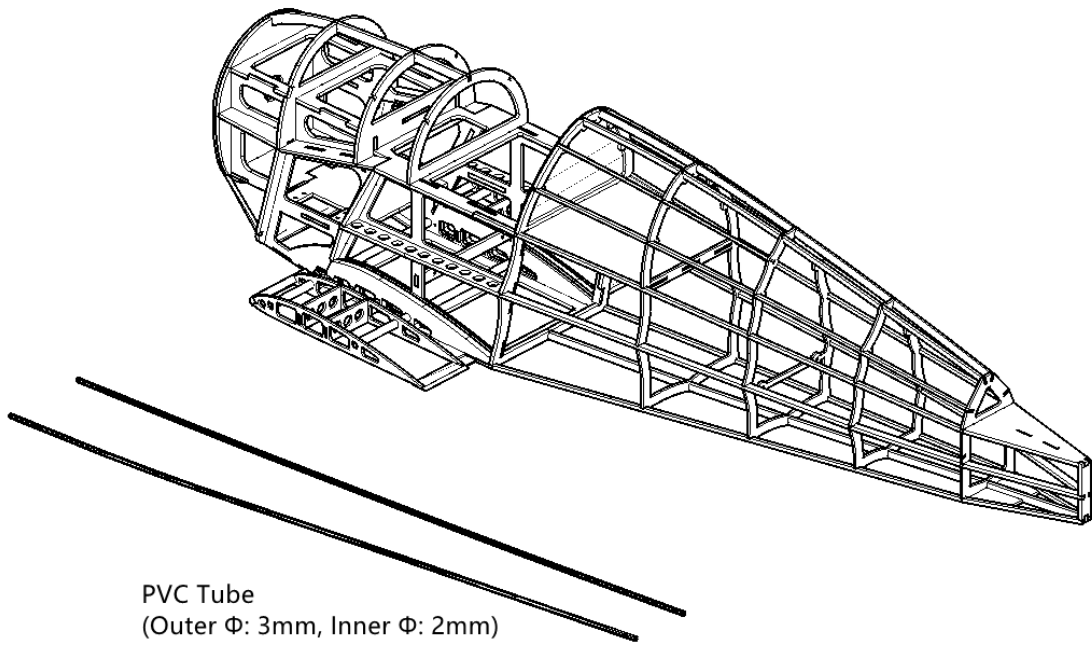

Step 58

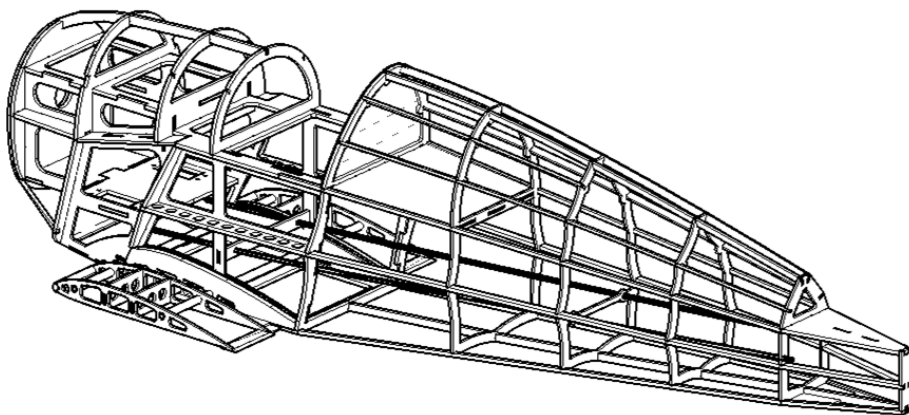

Step 59

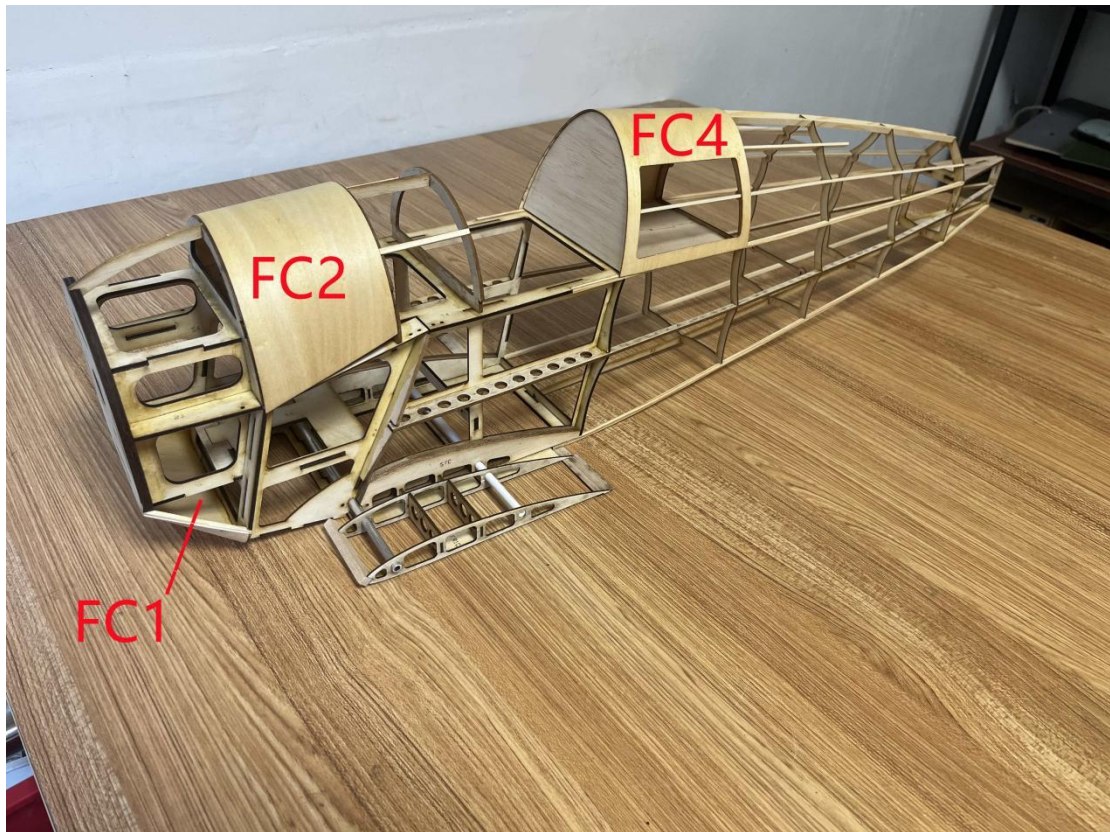

Step 60

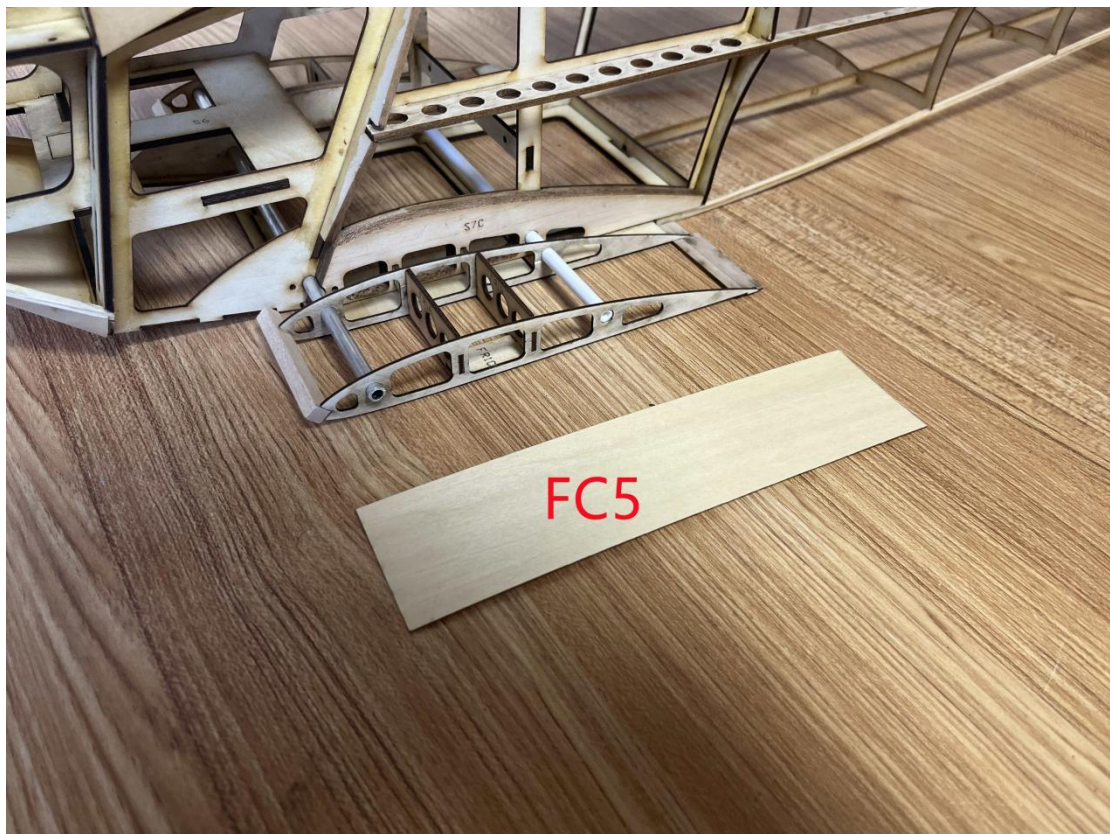

Step 61

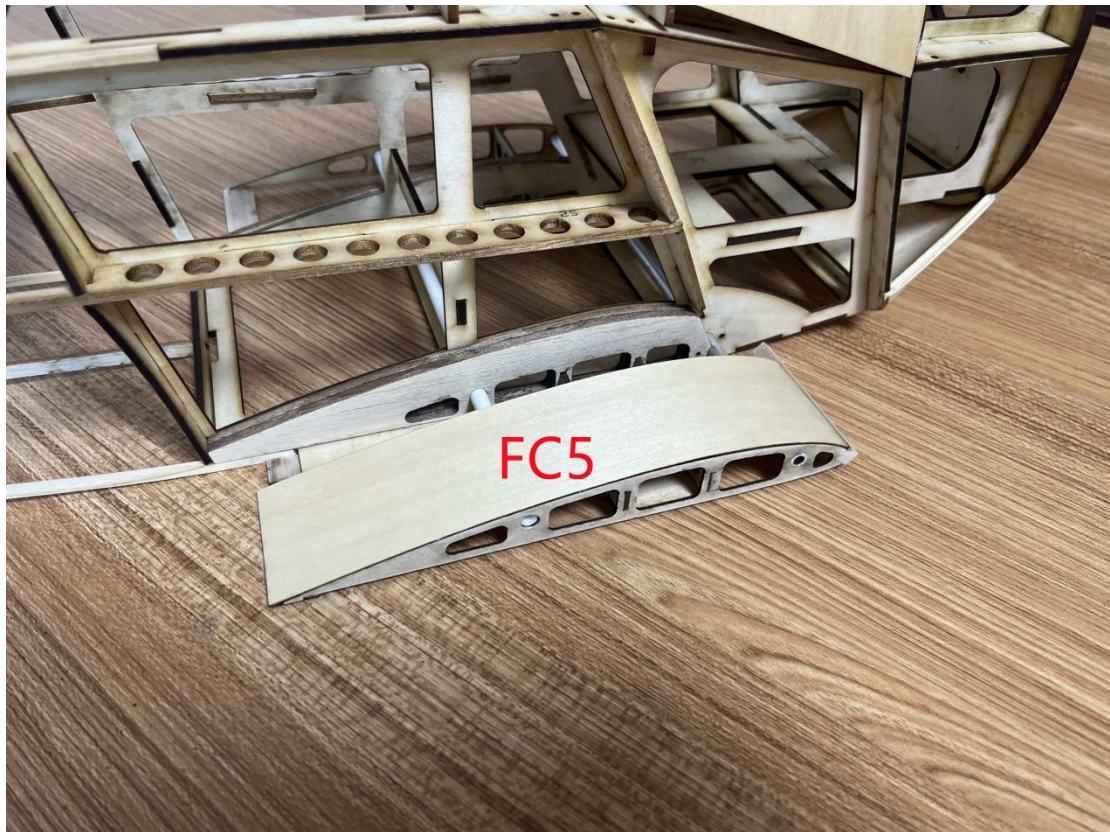

Step 62

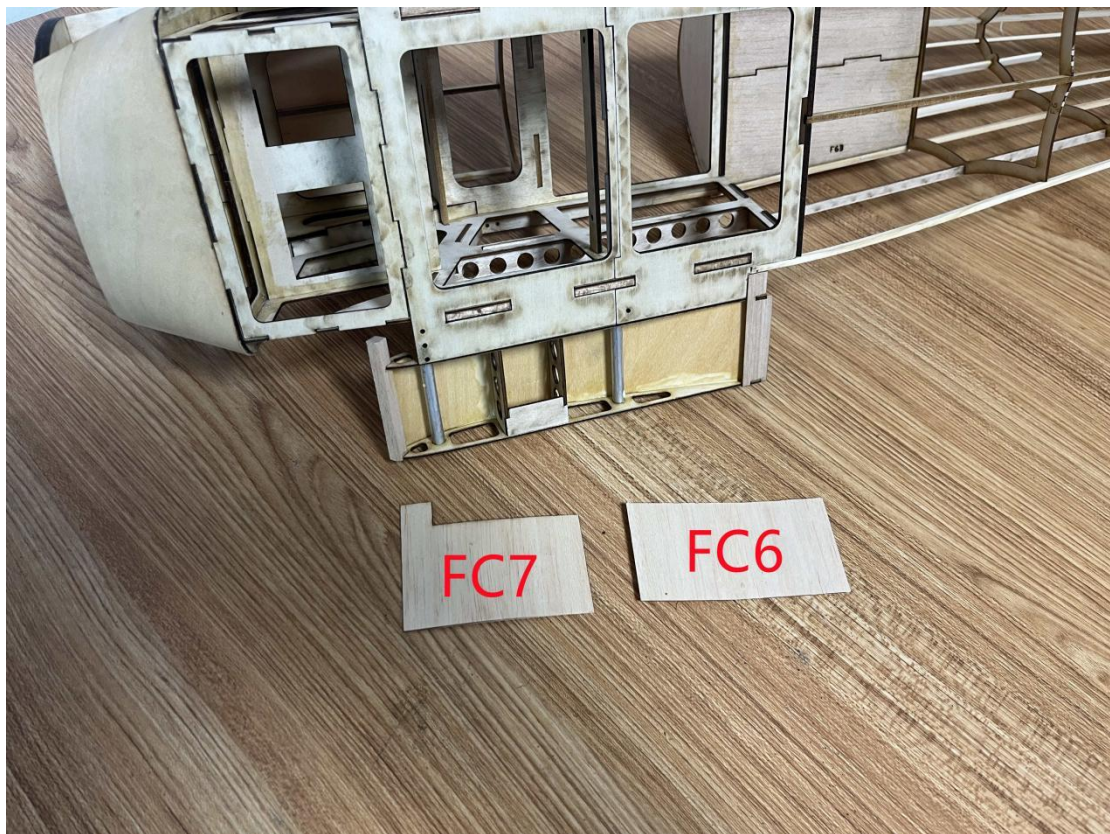

Step 63

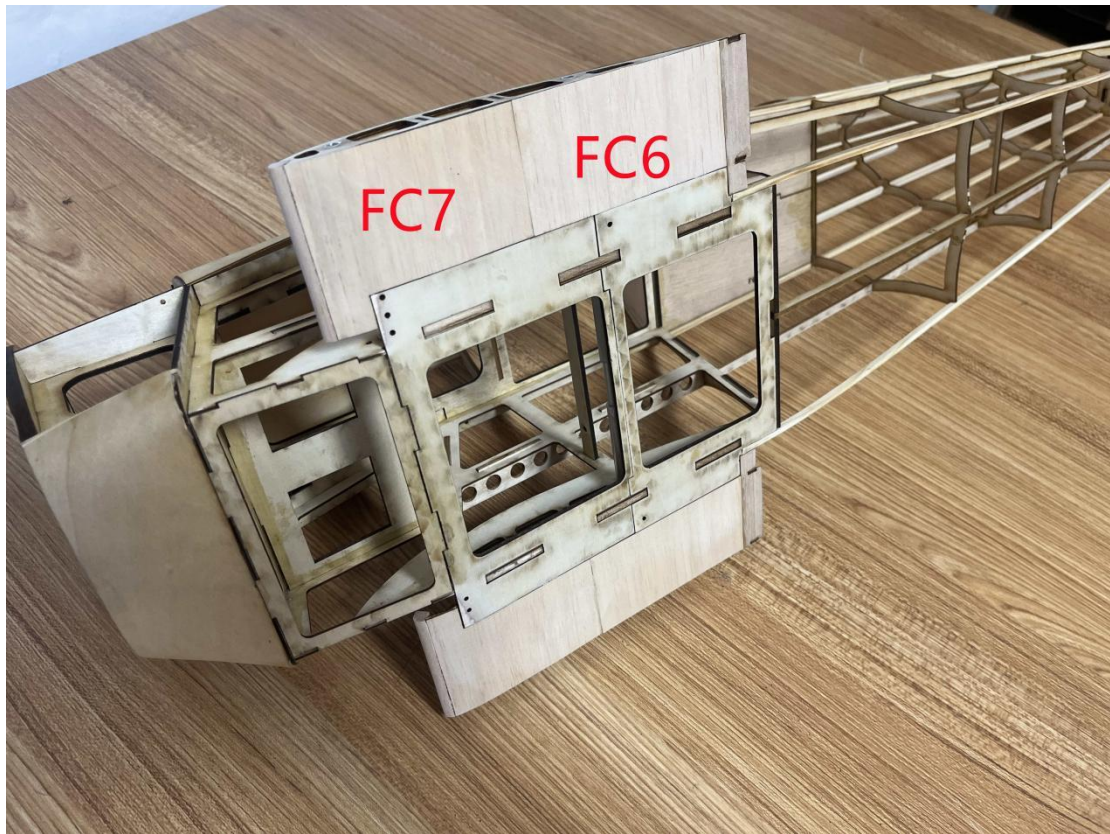

Step 64

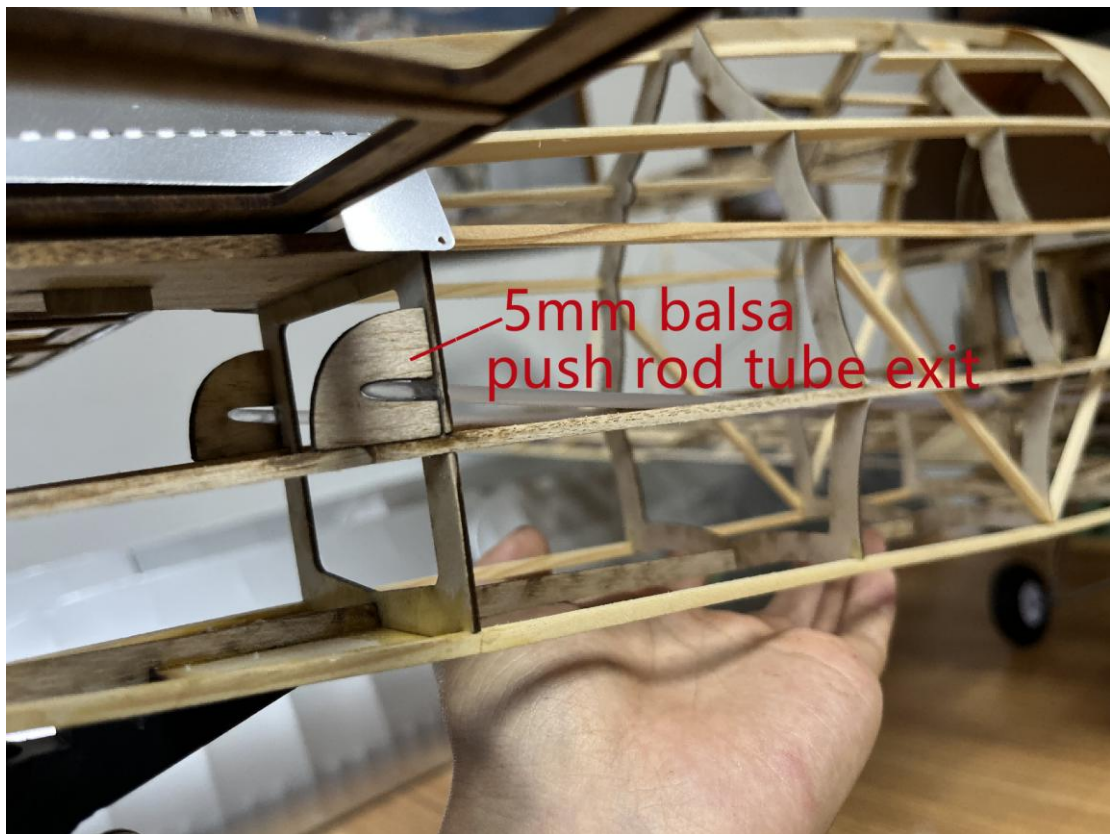

2. ASSEMBLY-Tails

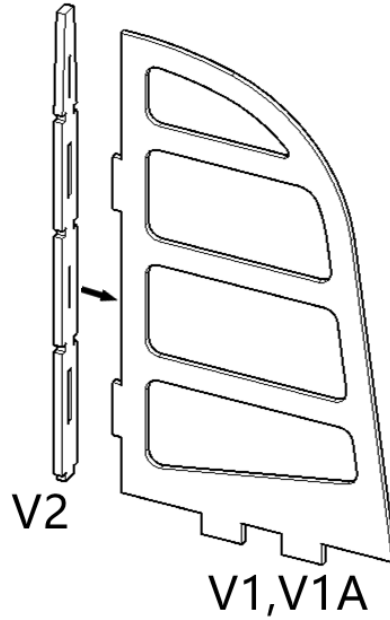

Step 1

Step 2

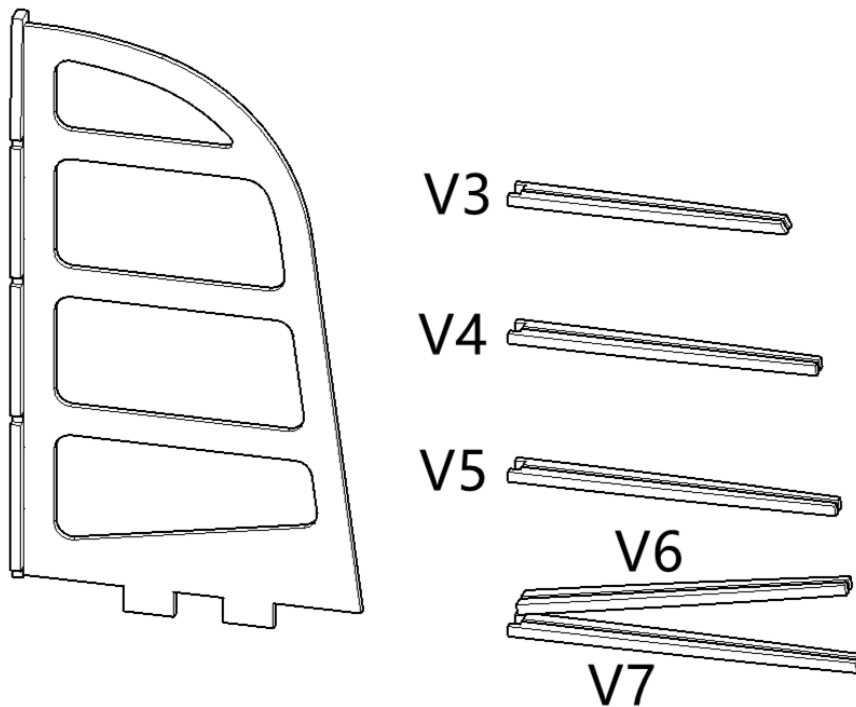

Step 3

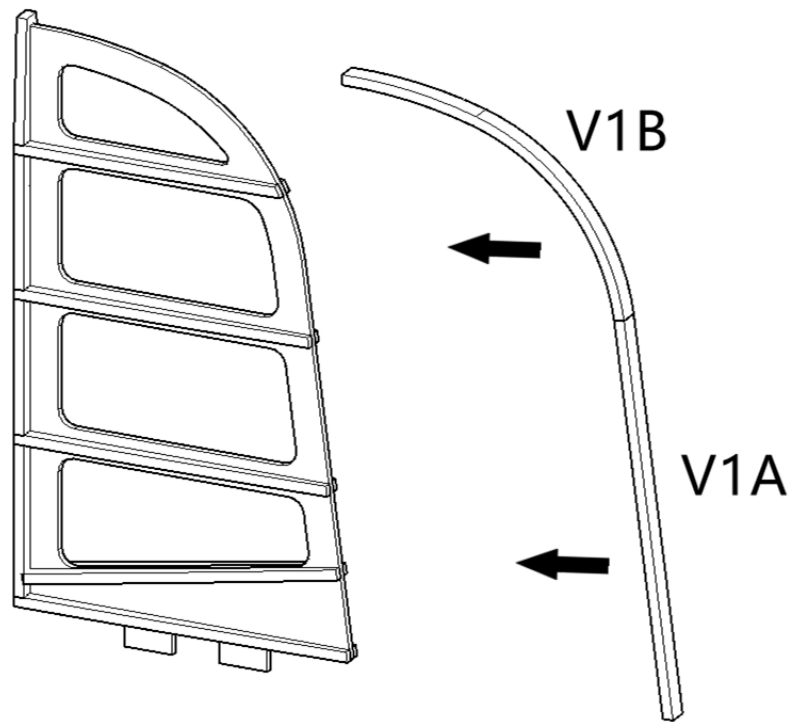

Step 4

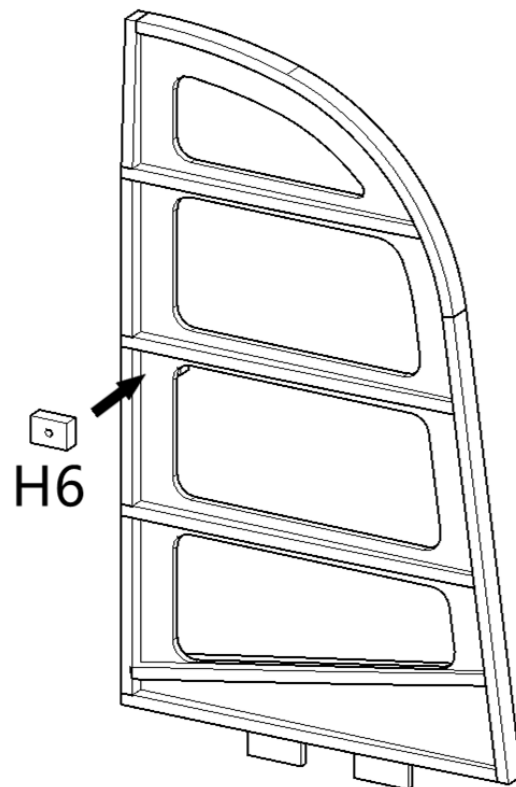

Step 5

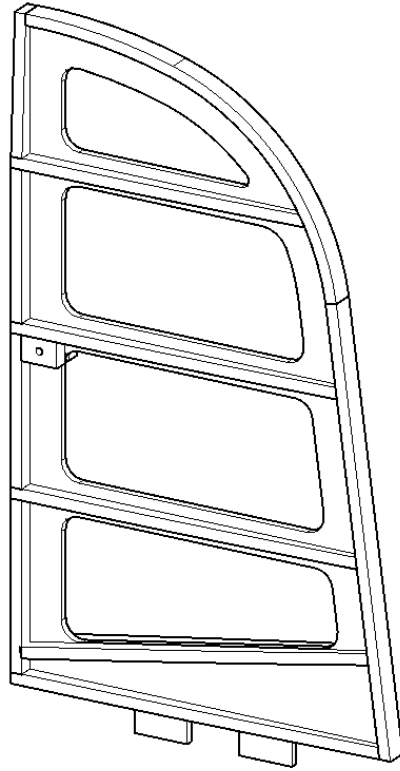

Step 6

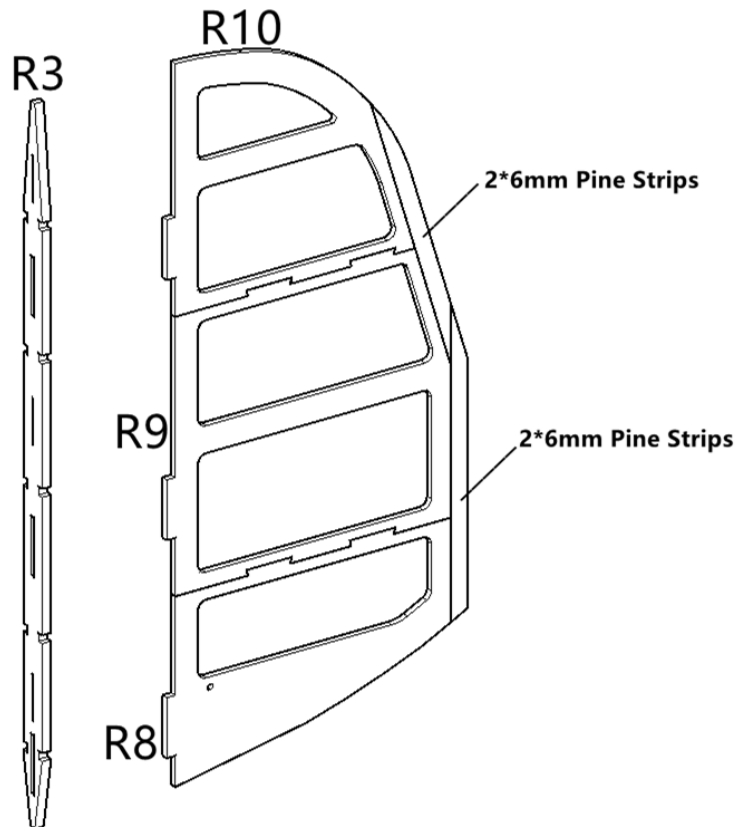

Step 7

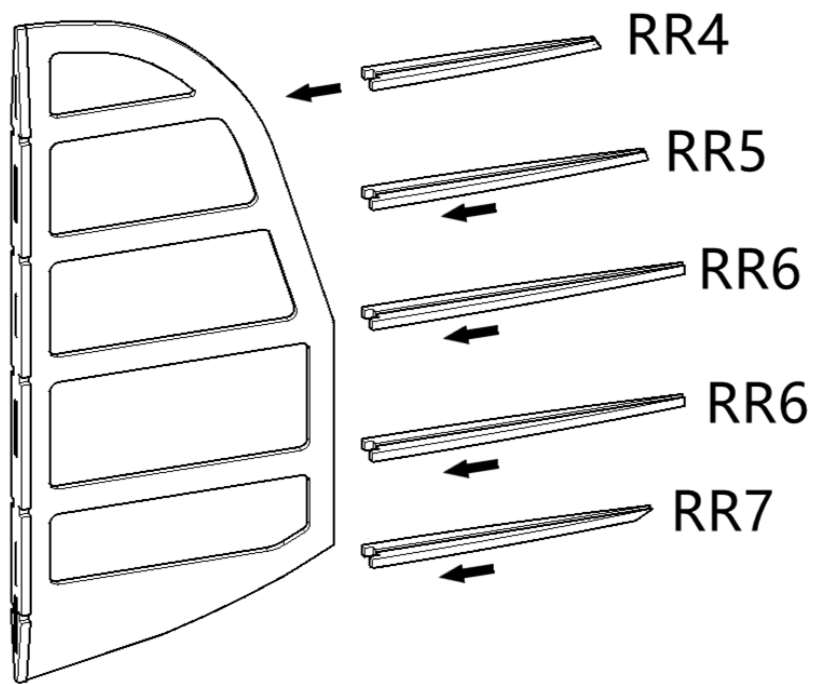

Step 8

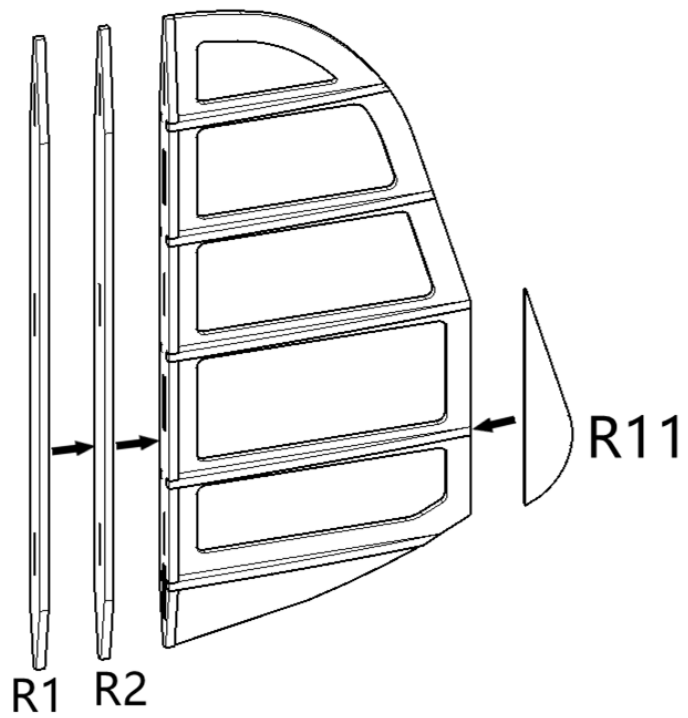

Step 9

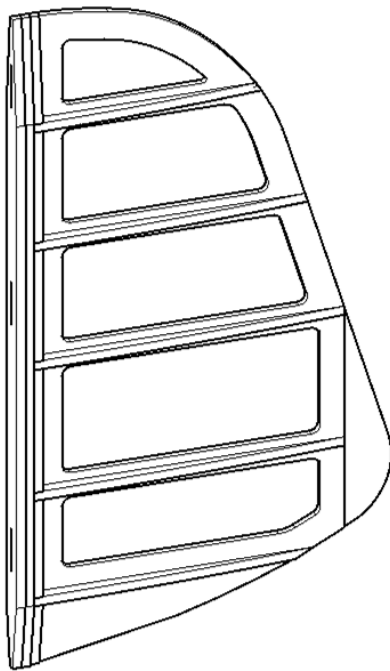

Step 10

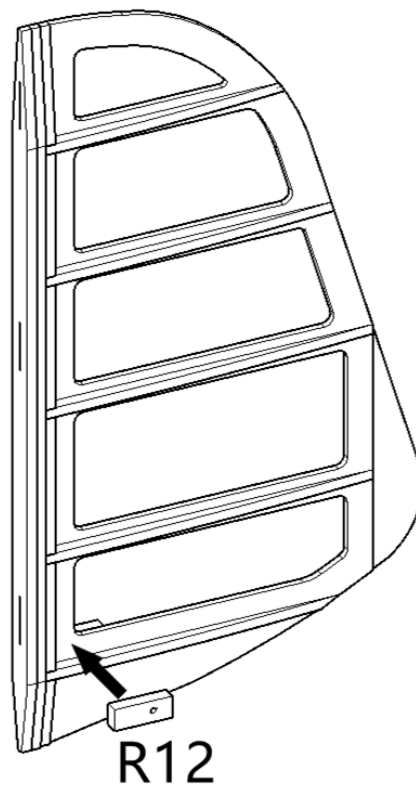

Step 11

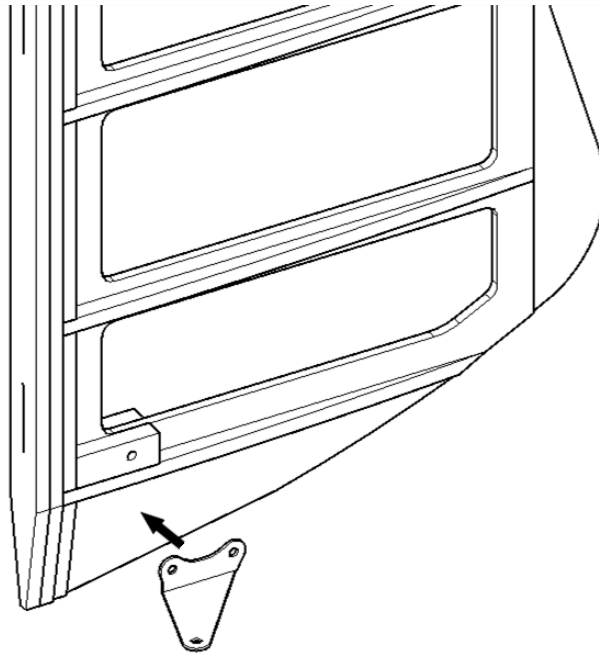

Step 12

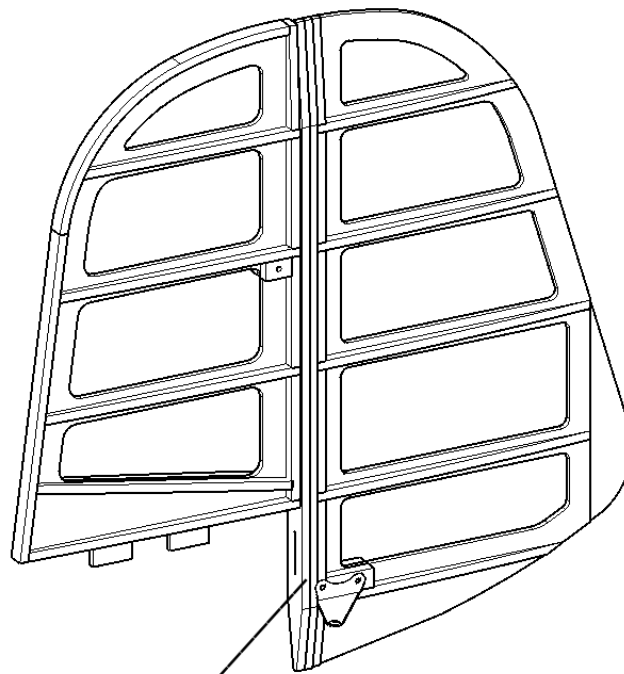

Sand this edge to bevel

Step 13

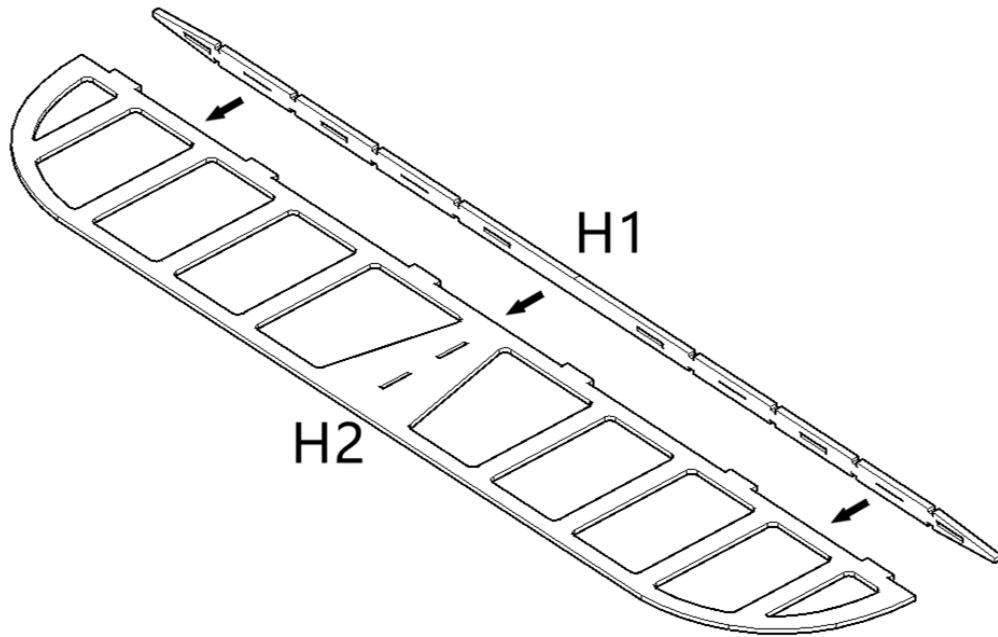

Step 14

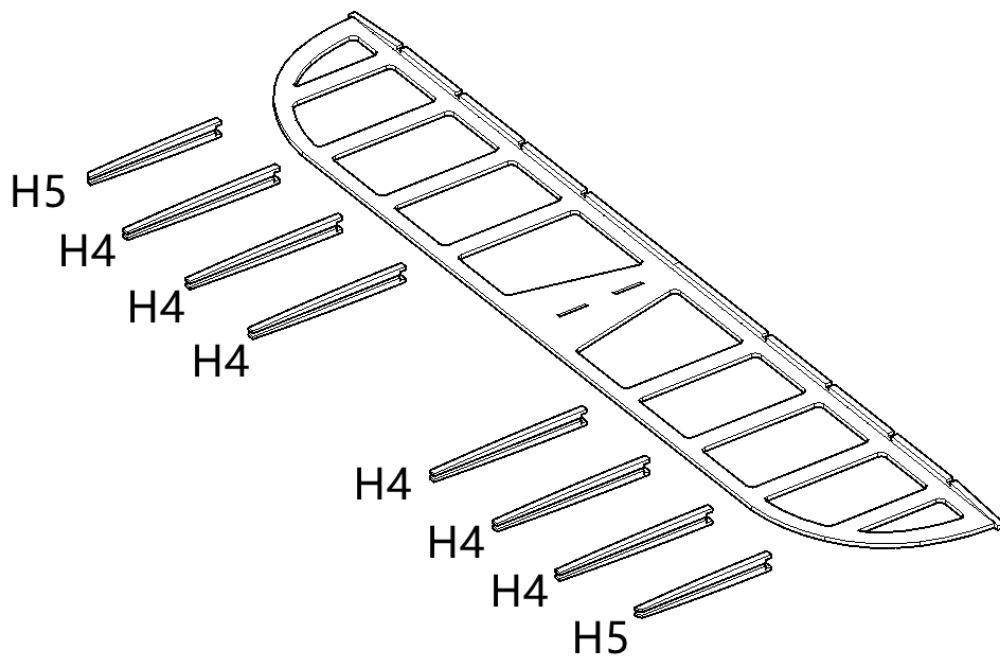

Step 15

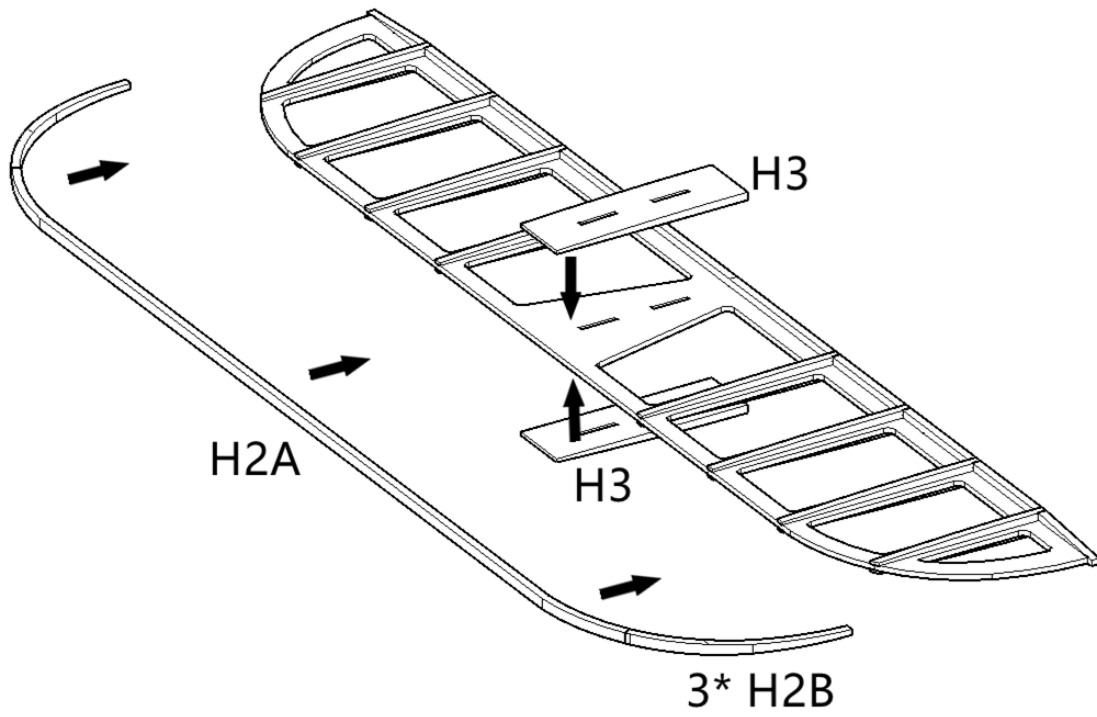

Step 16

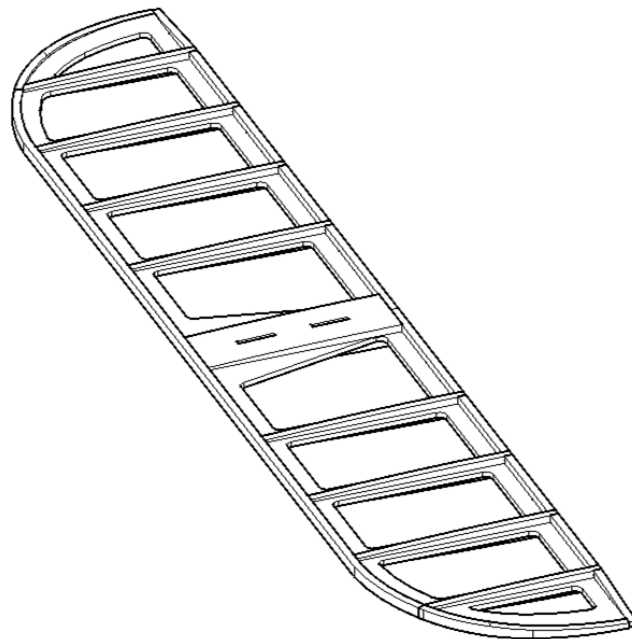

Step 17

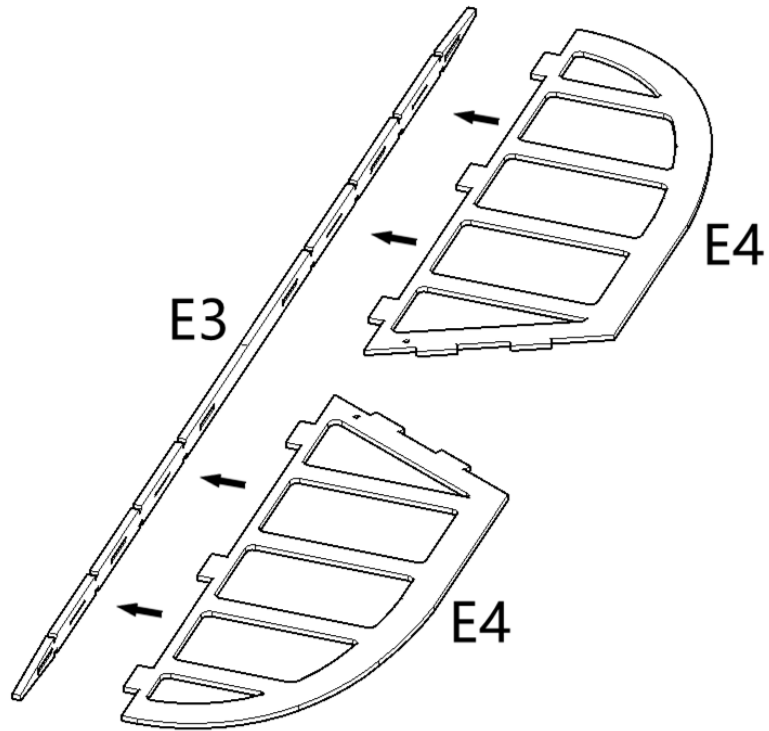

Step 18

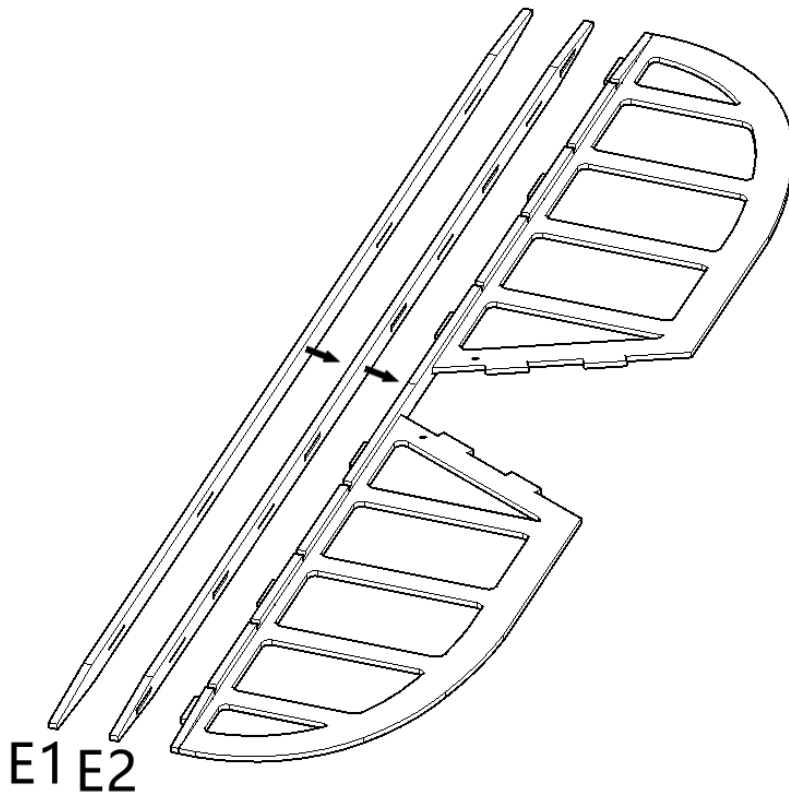

Step 19

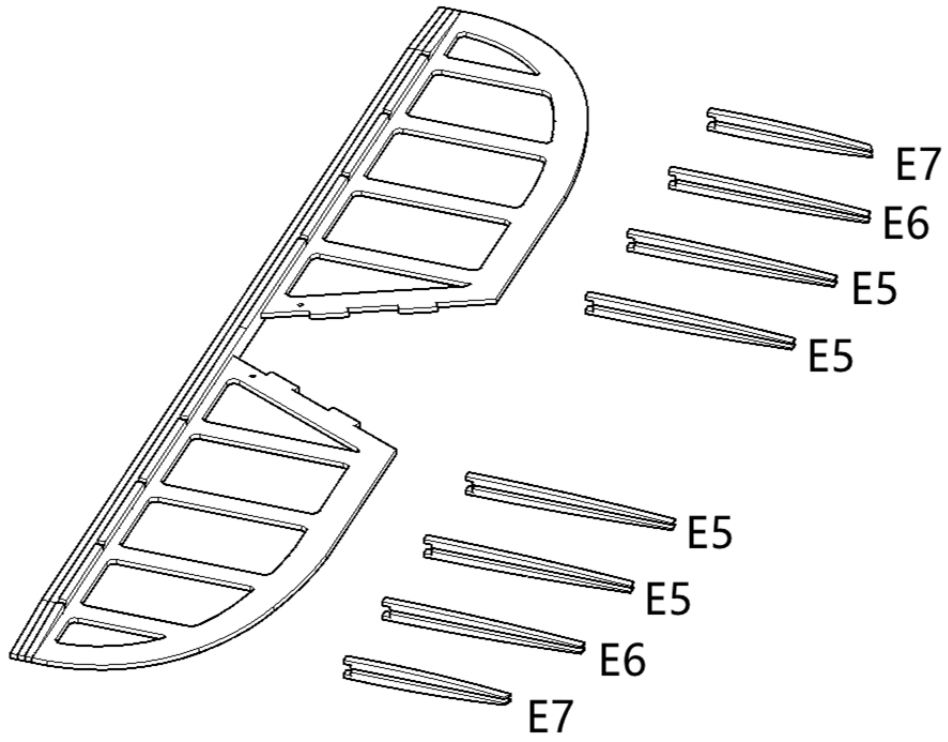

Step 20

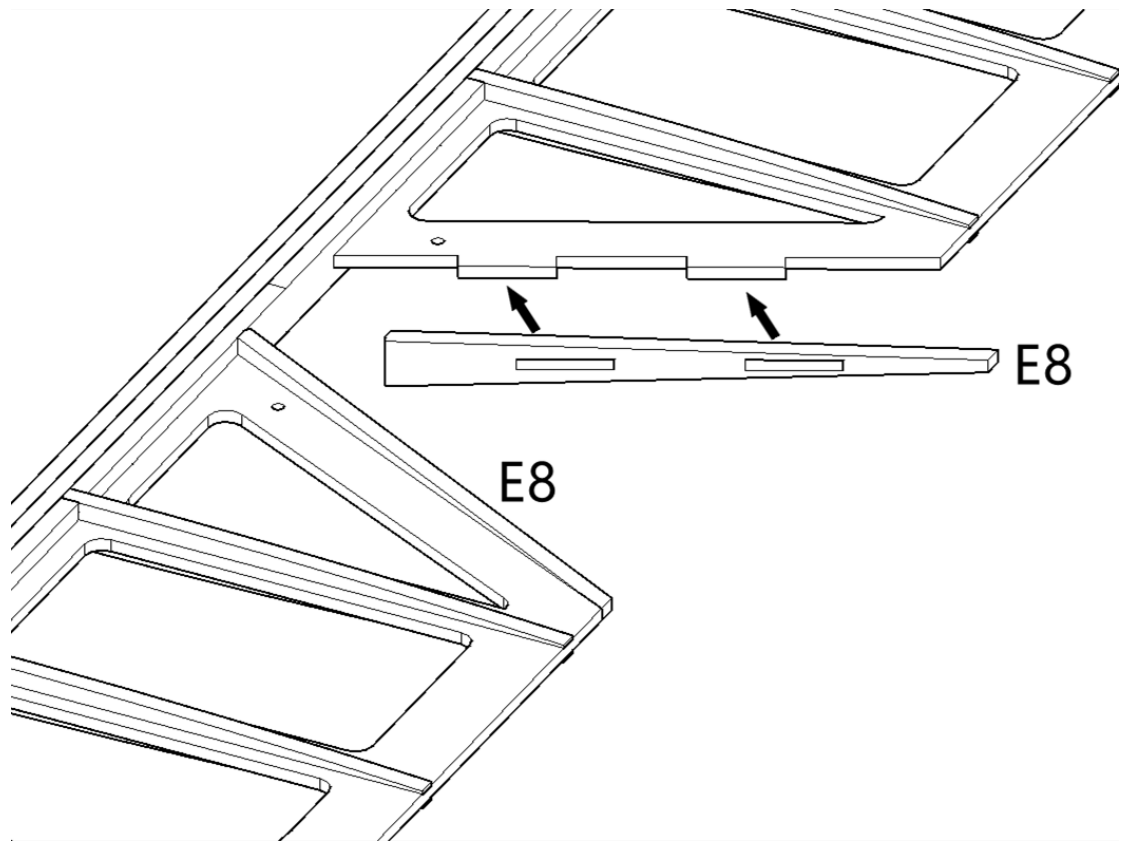

Step 21

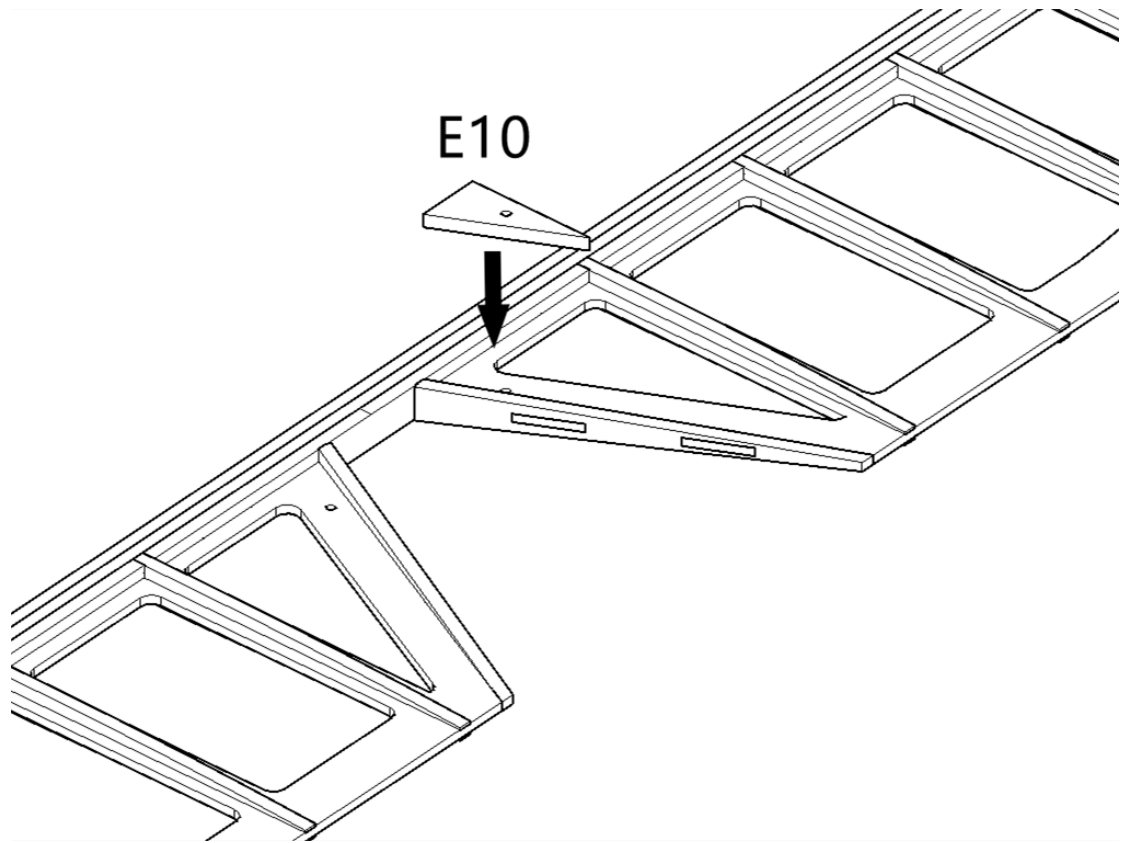

Step 22

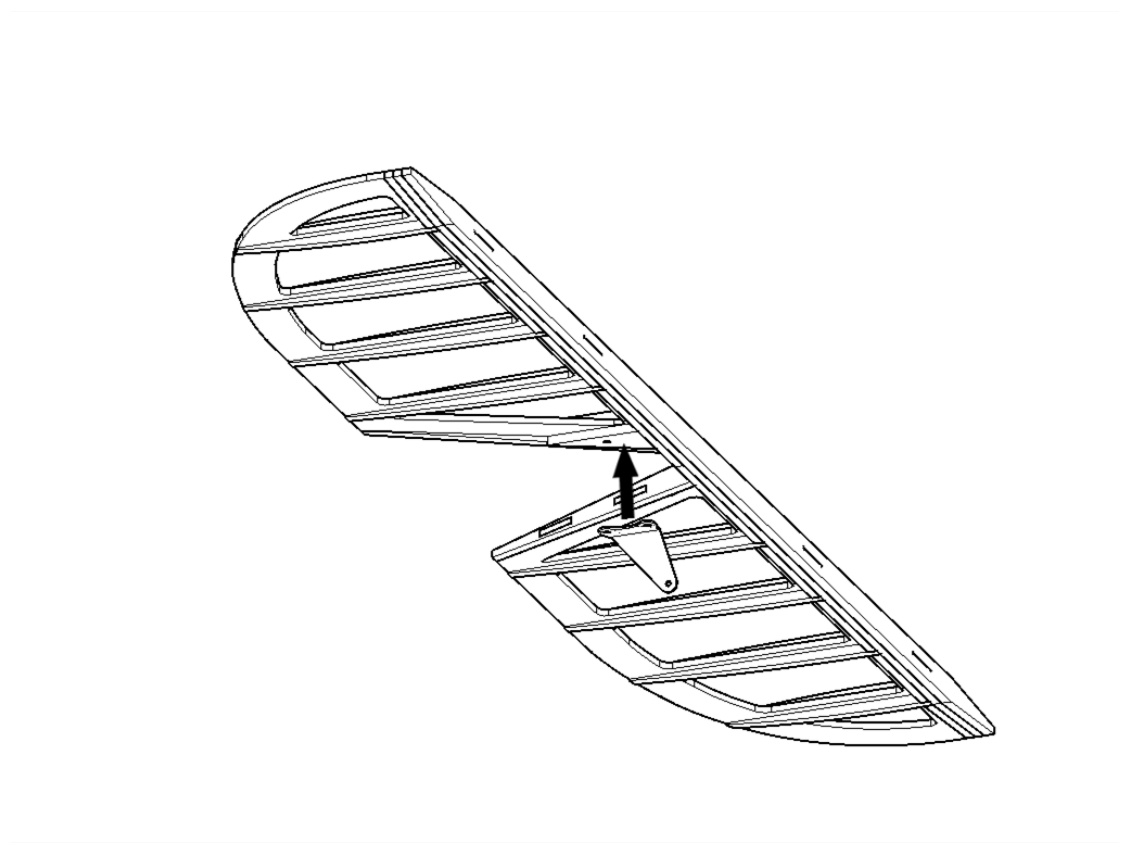

Step 23

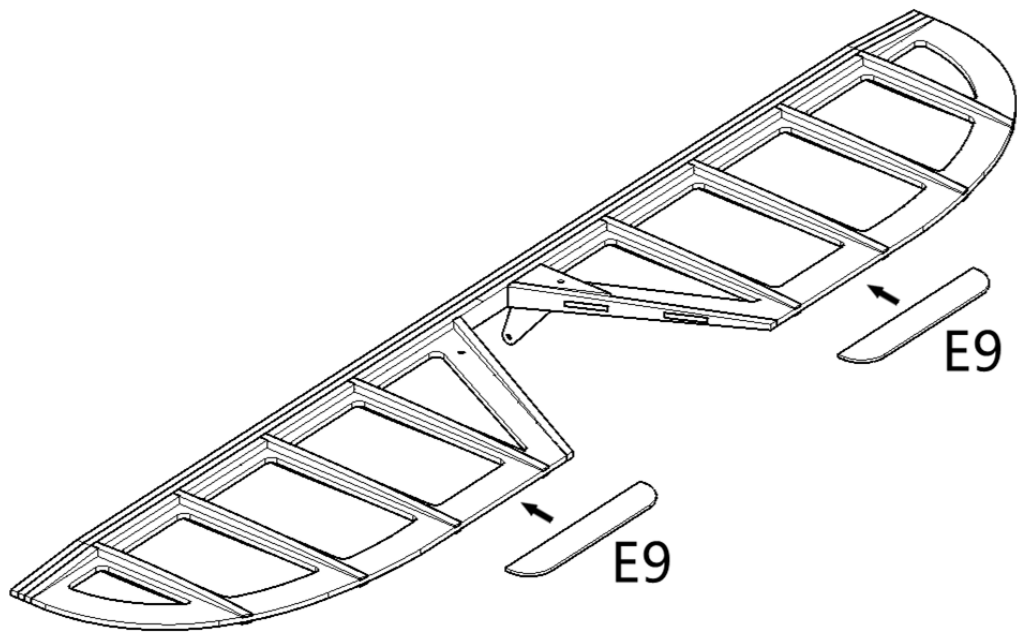

Step 24



Step 25



Step 26

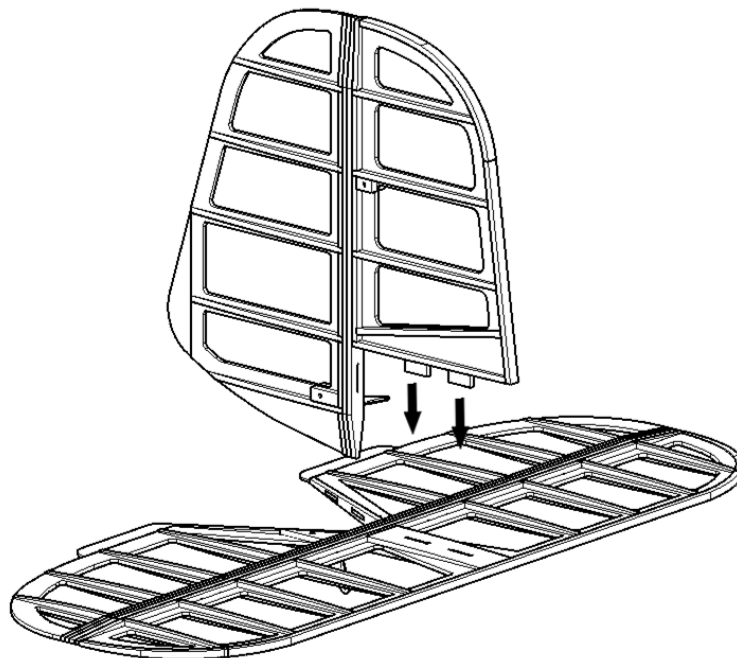

Step 27

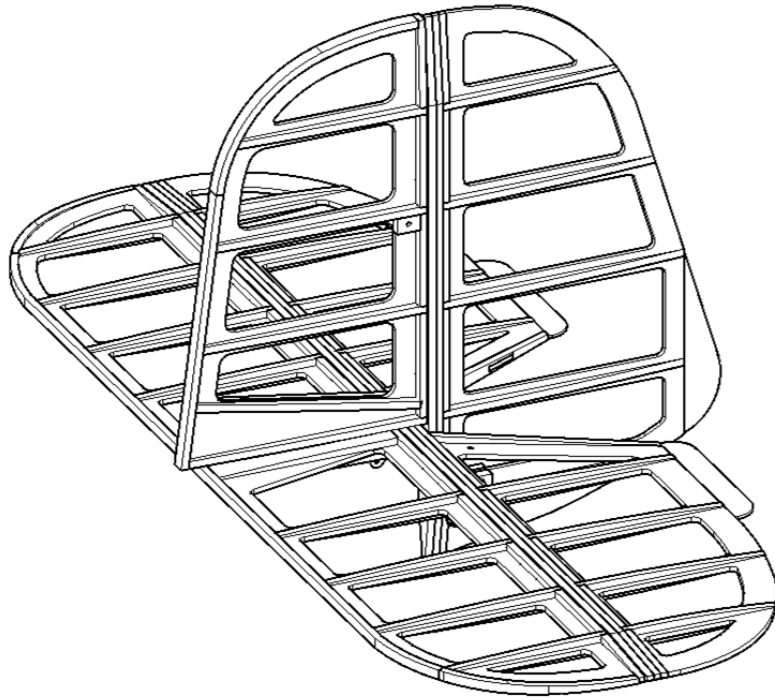

My Nots:

3.ASSEMBLY-Central wing

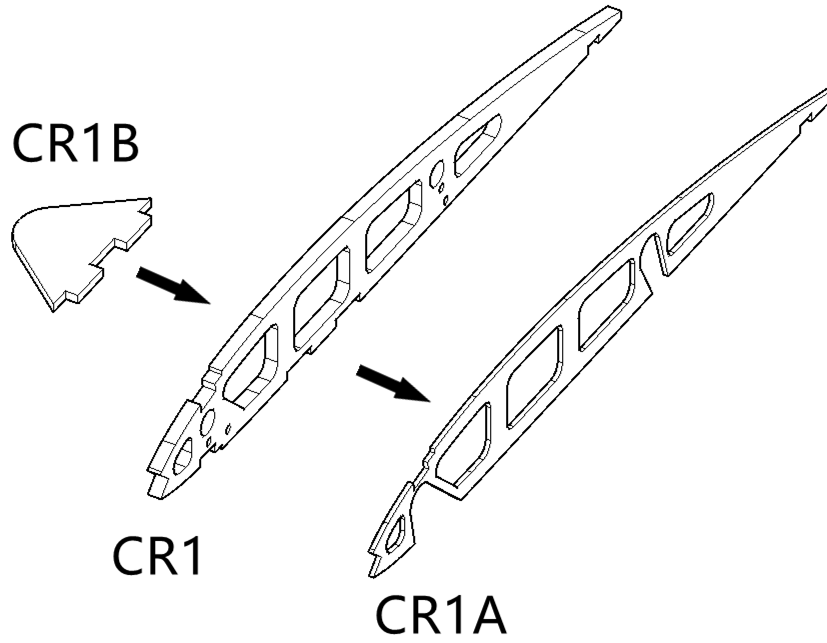

Step 1

Step 2

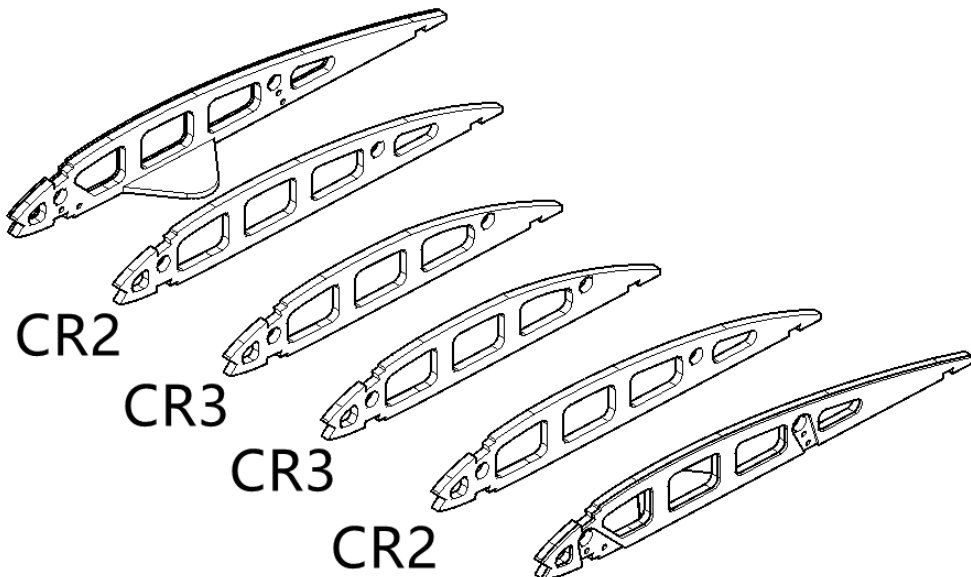

Step 3

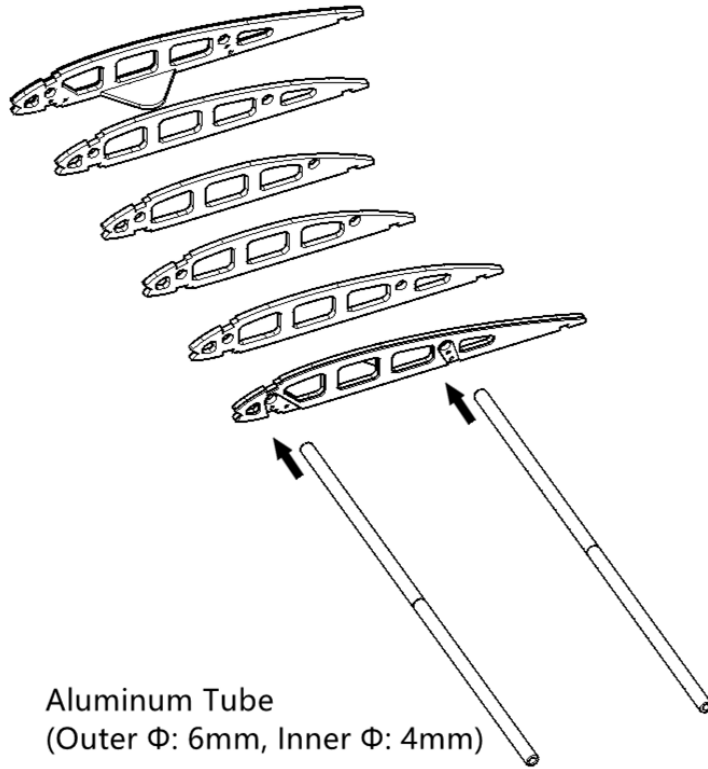

Step 4

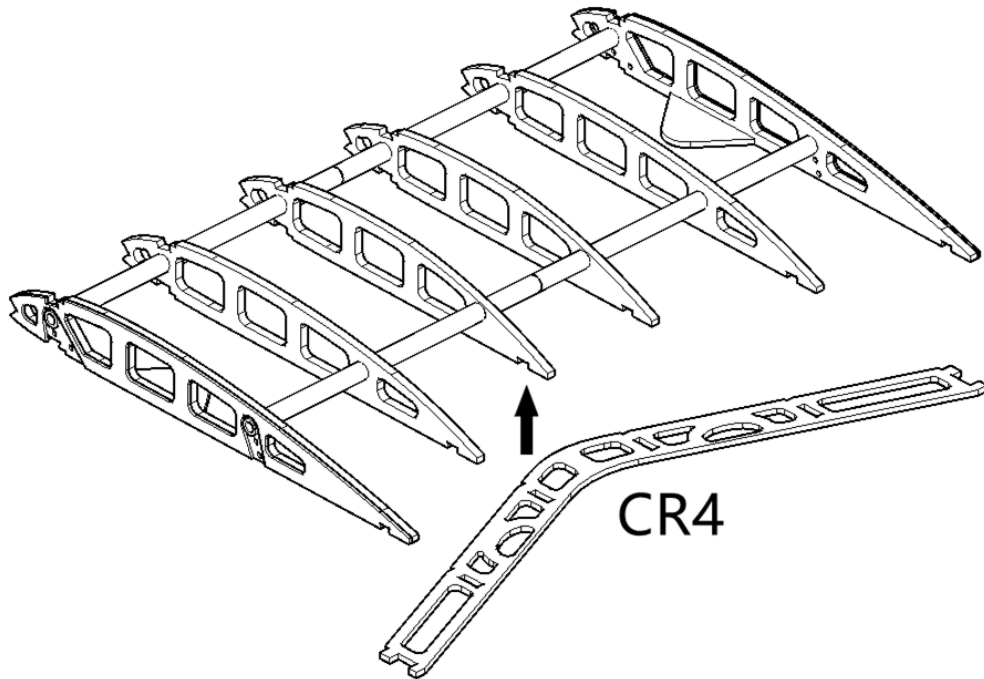

Step 5

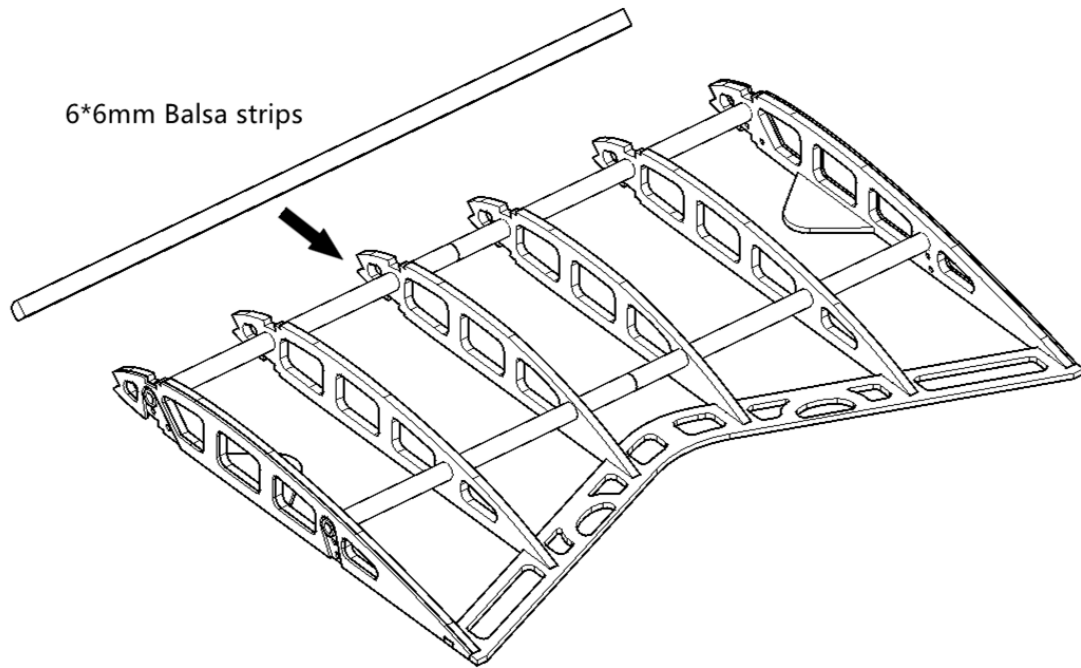

Step 6

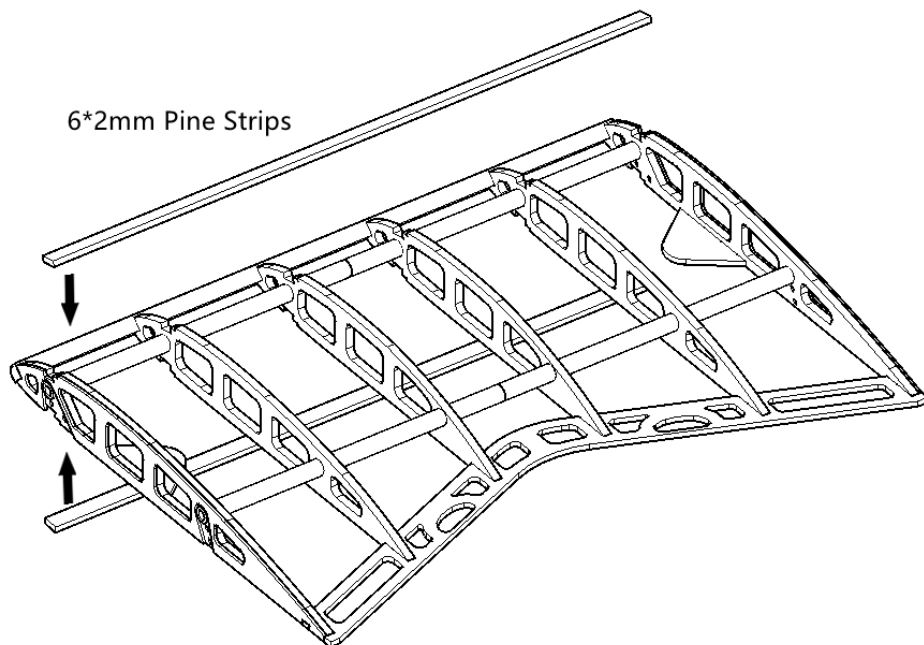

Step 7

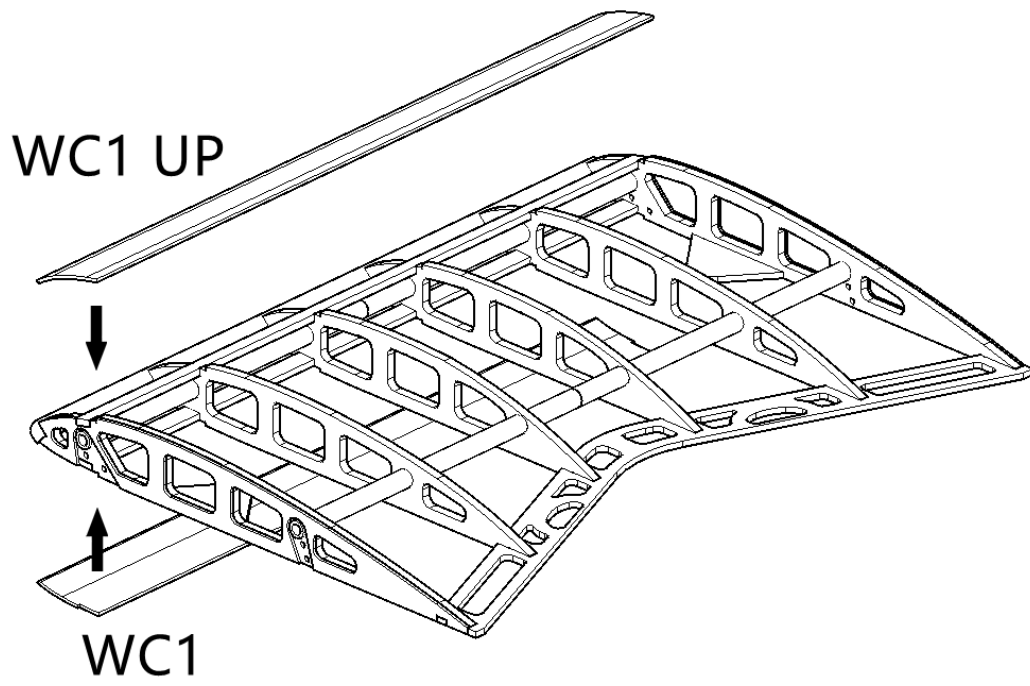

Step 8

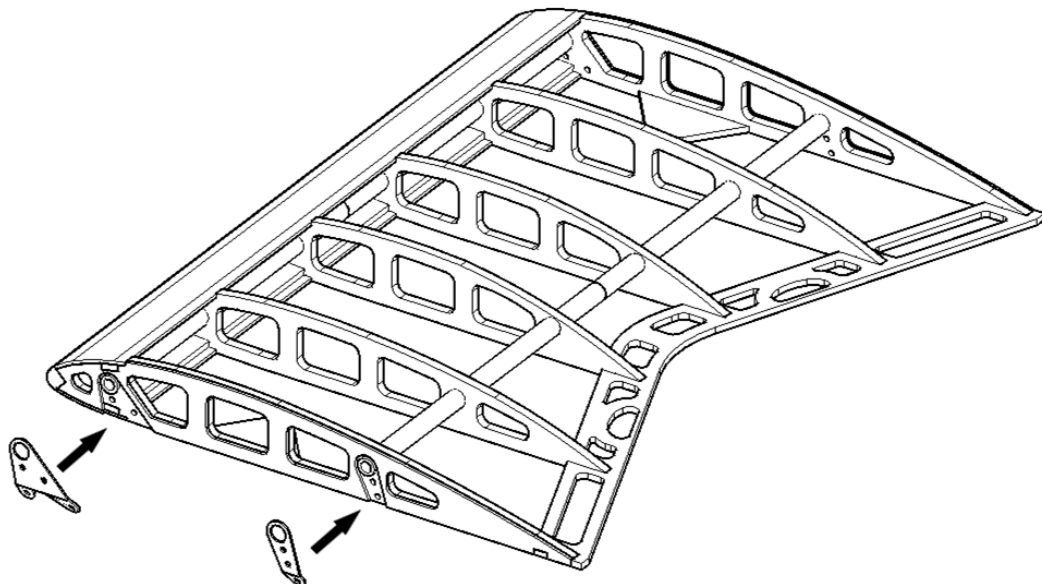

Step 9

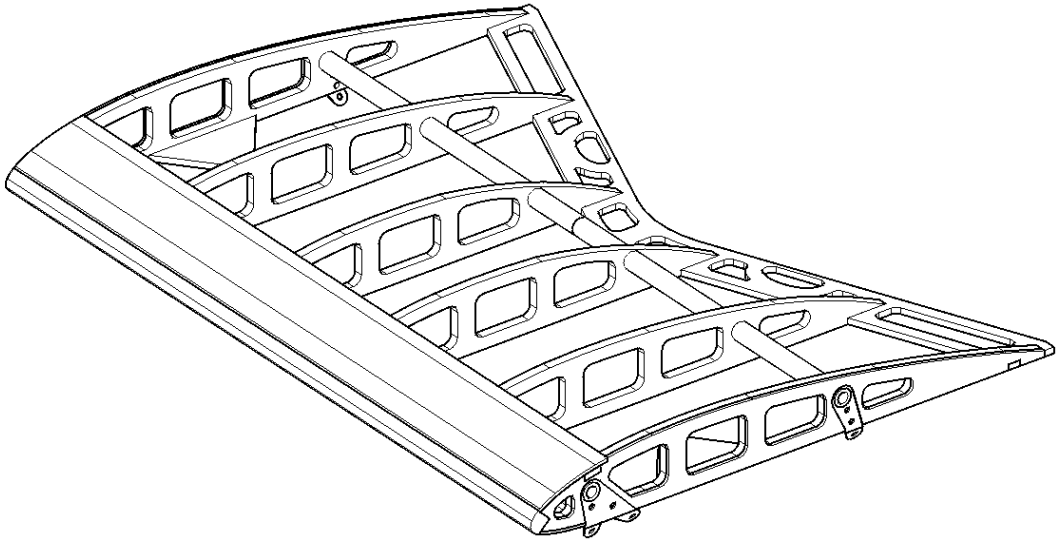

Step 10



Step 11



Step 12

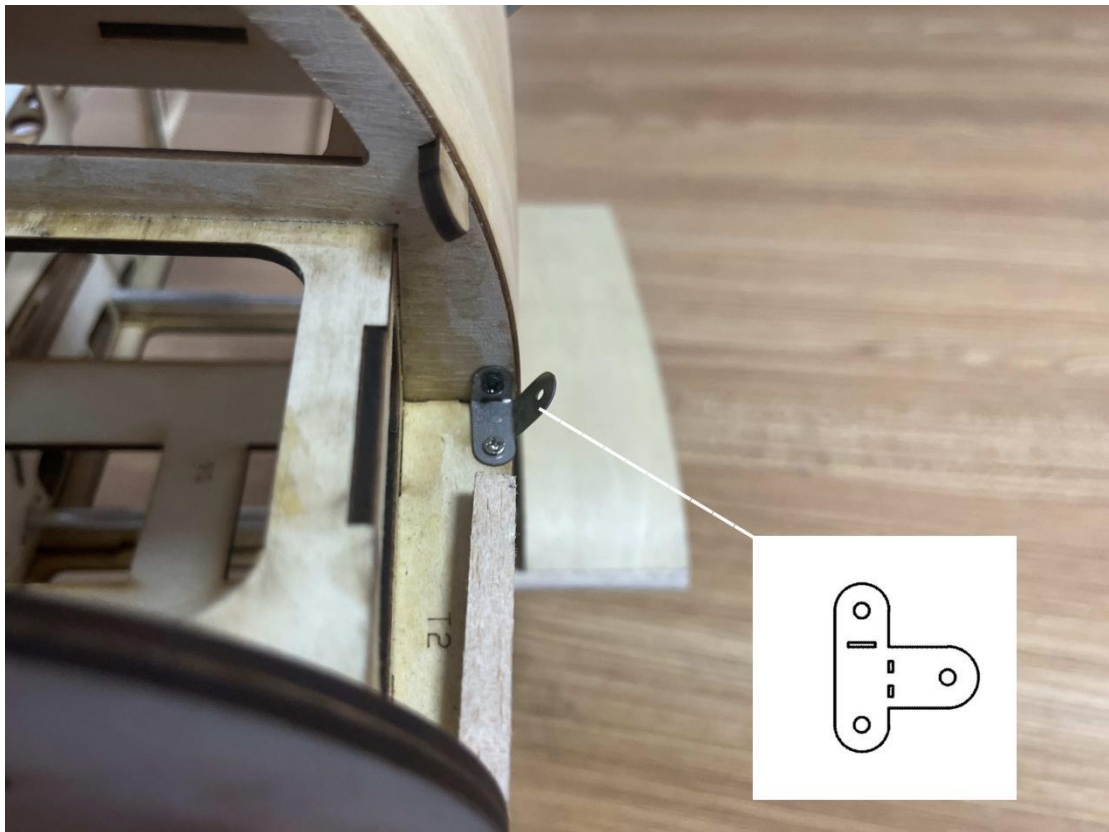

Step 13



Step 14



Step 15



Step 16

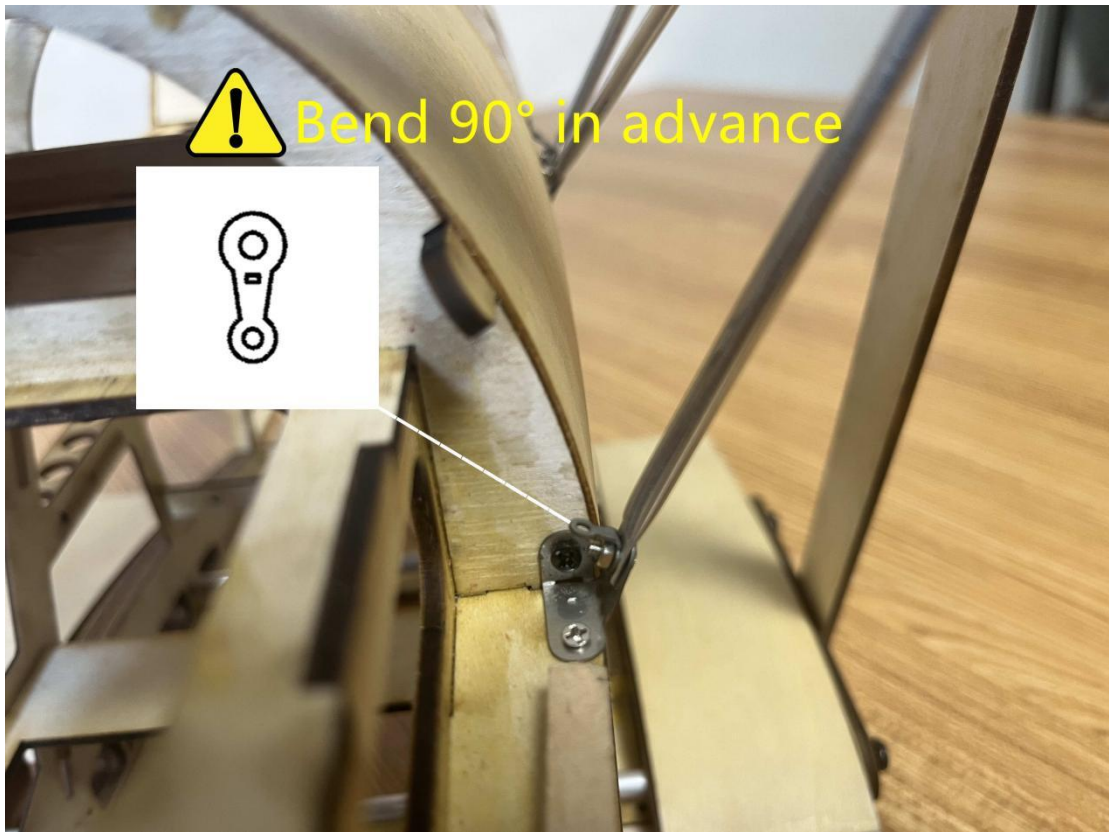

Step 17



Step 18

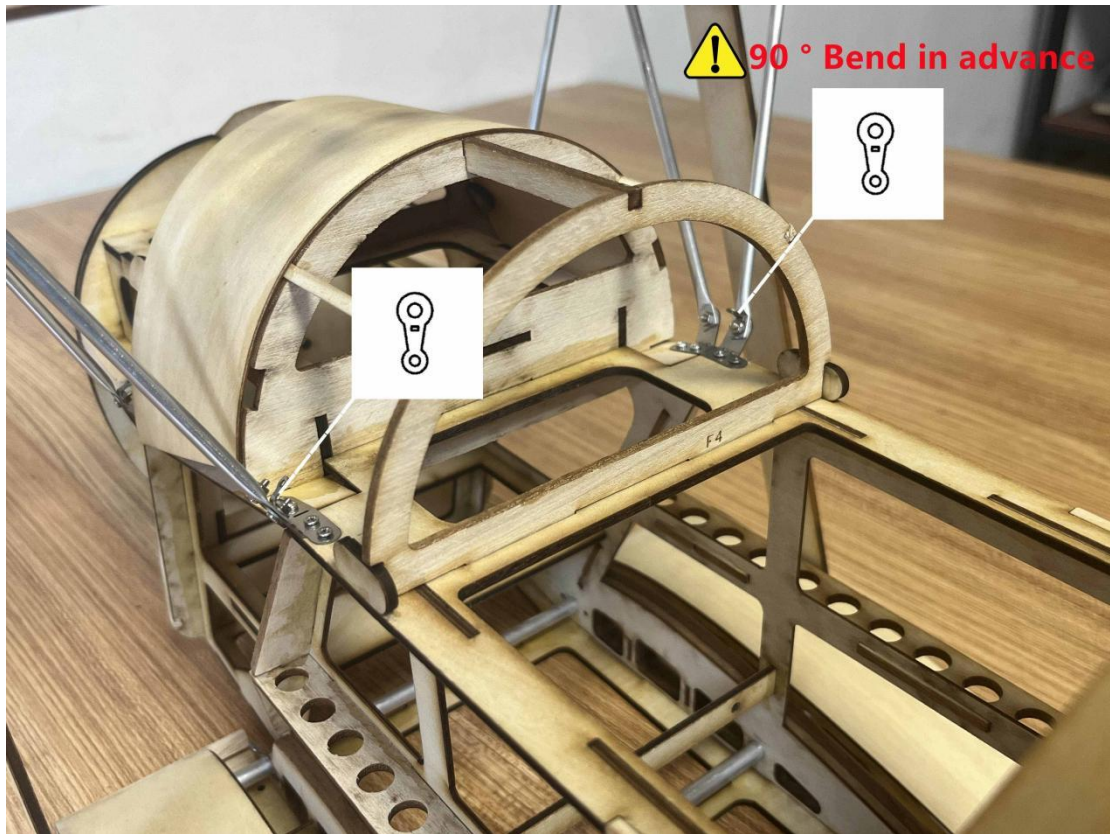

Step19



Step 20

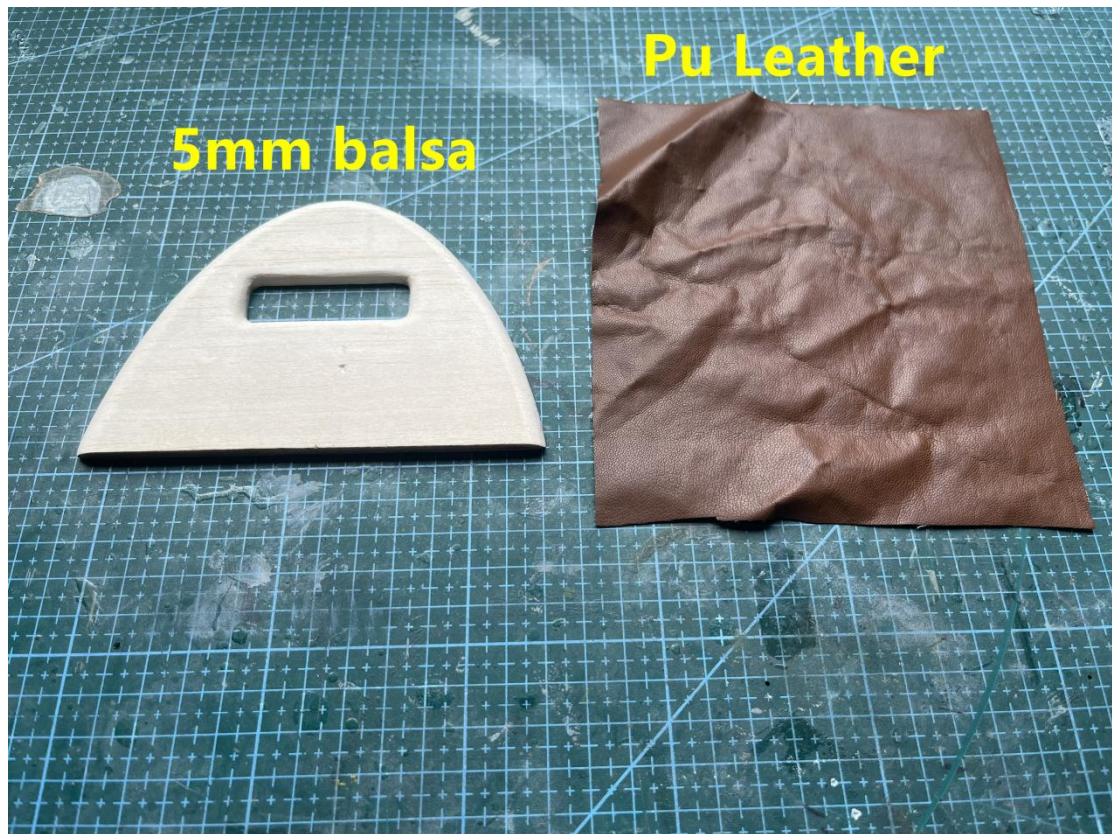

Step 21



Tips: How to cover the parts using leather:



1. Apply a layer of glue on the components
2. Cover the parts with leather, making the front of the parts as tight as possible and without wrinkles
3. Use a small electric iron to adjust the temperature to 135 °C to iron the surface to solidify the glue
4. Brush the glue again at the edge of the leather, then iron it with an iron, stick to the edge, and press the folds. There can be wrinkles on the back

My Notes:

4.ASSEMBLY-Cabin Doors & Panel

Step 1



Step 2



Step 3



Step 4

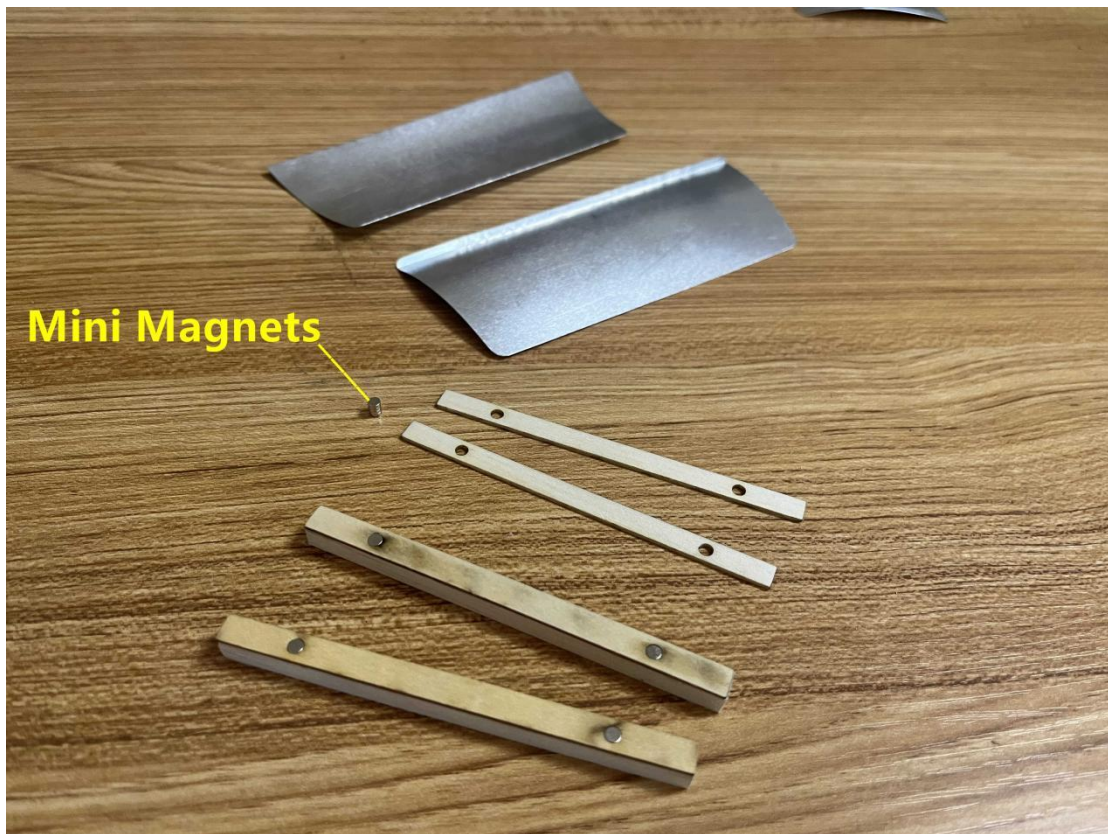

Step 5



Step 6

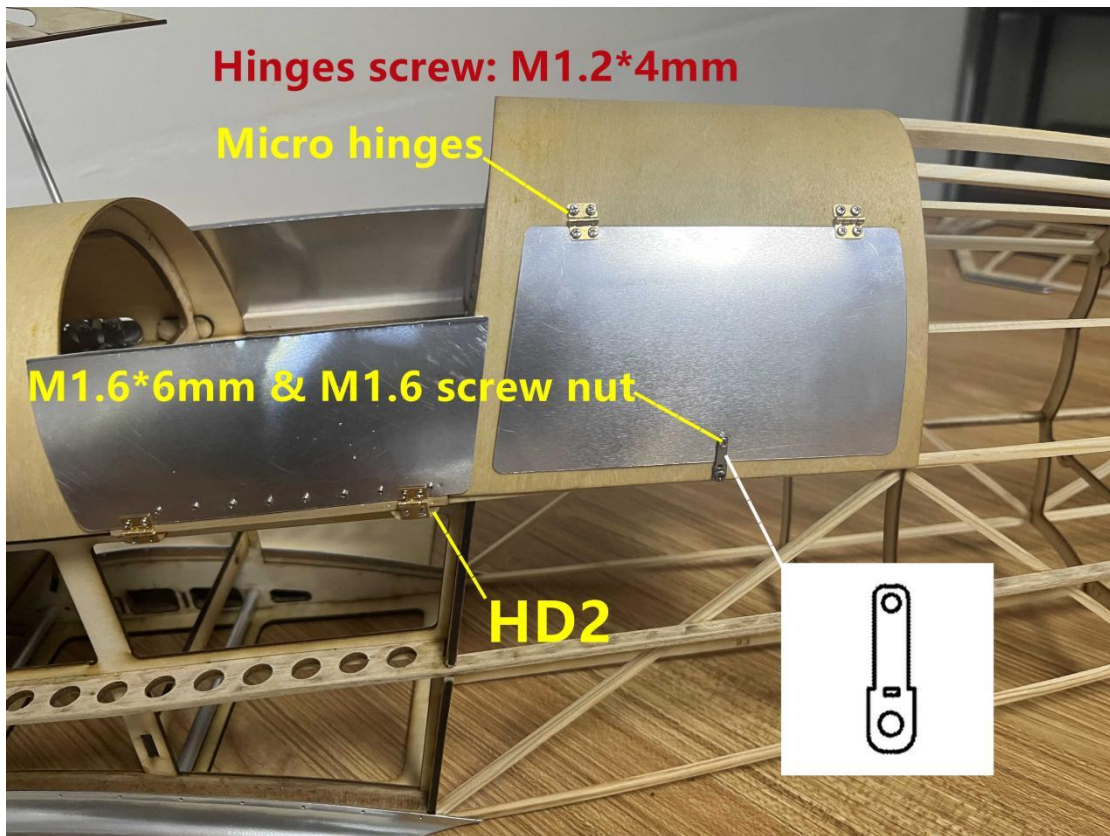

Step 7

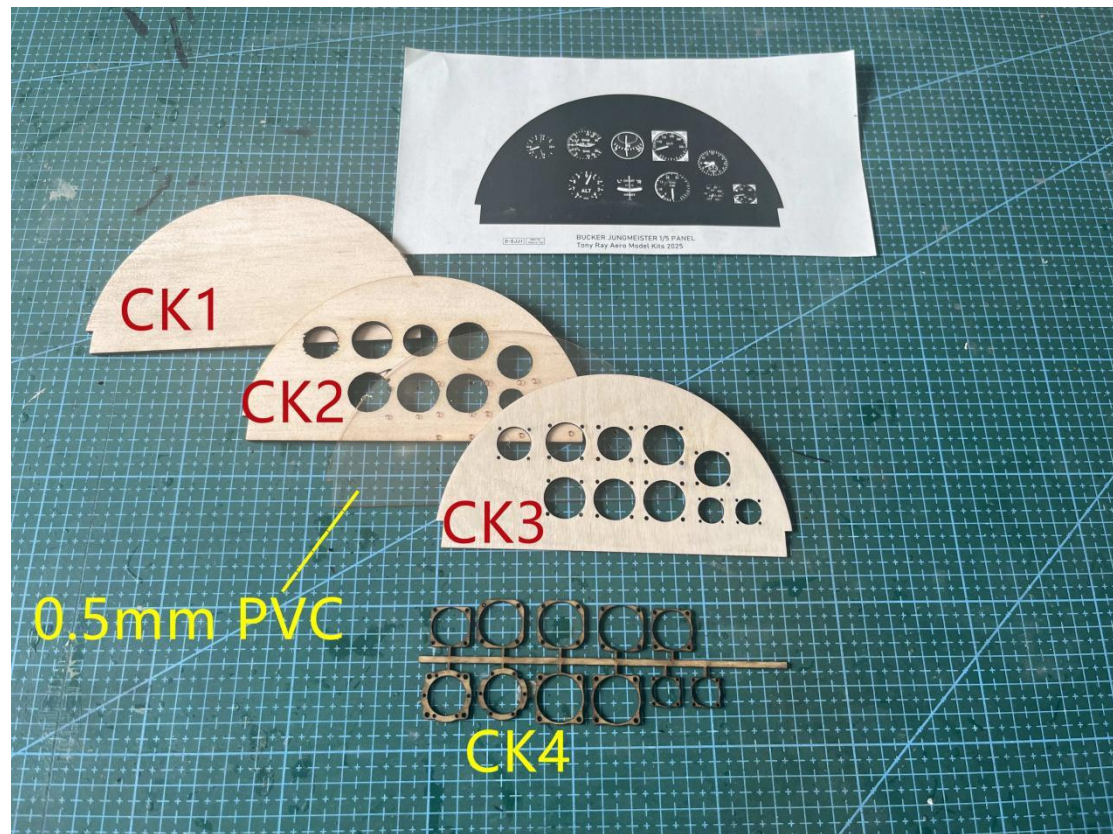

Step 8



5.ASSEMBLY-Landing Gear

Step 1



Step 2



Step 3

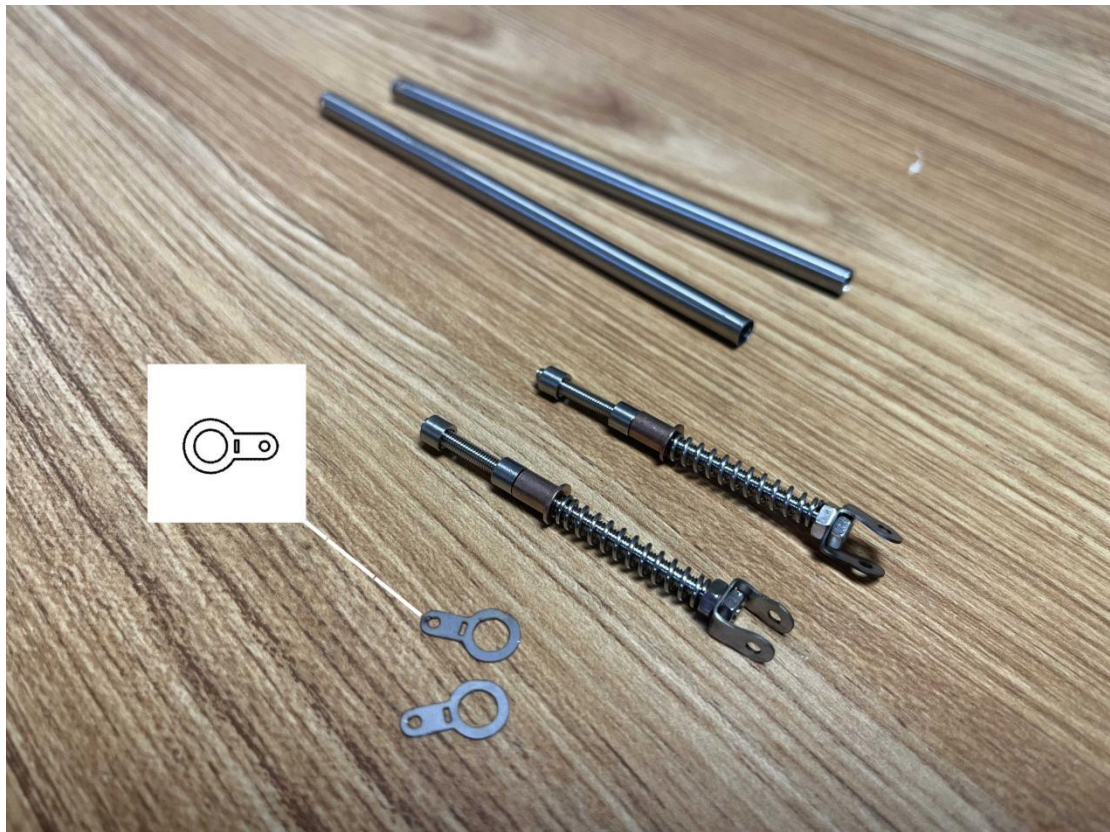

Step 4

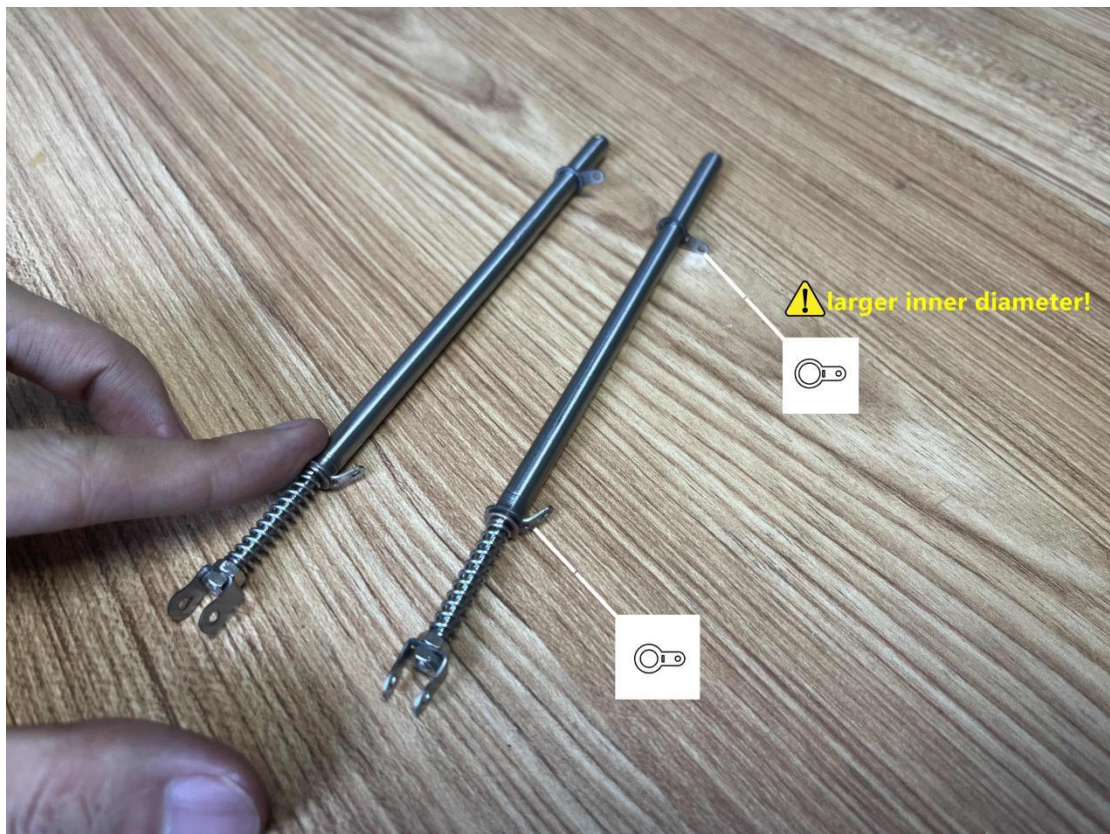

Step 5



Step 6



Step 7



Step 8

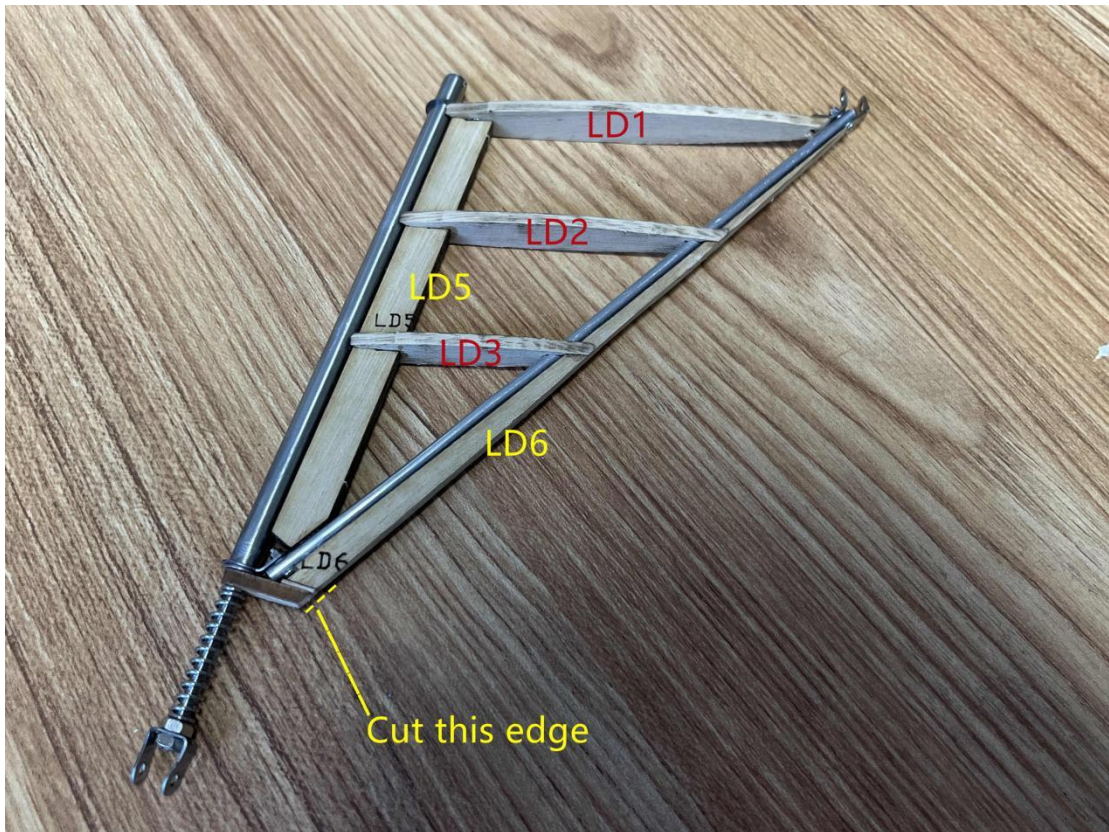

Step 9

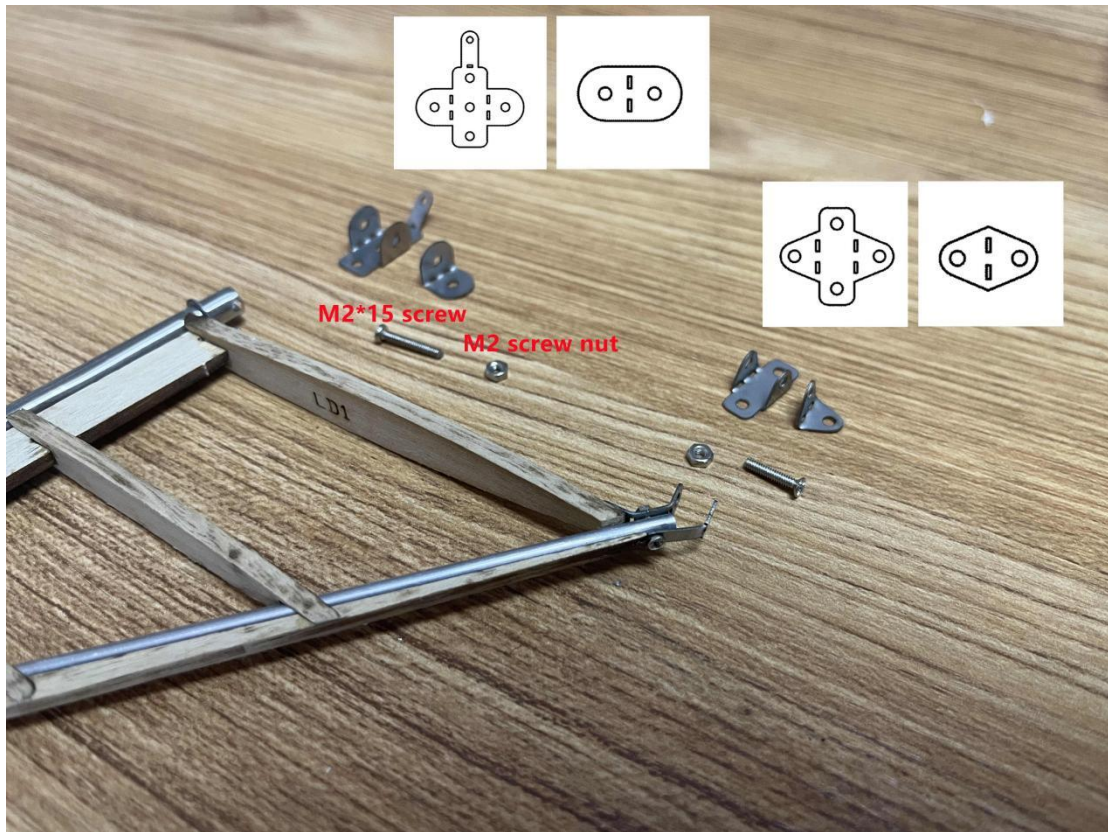

Step 10

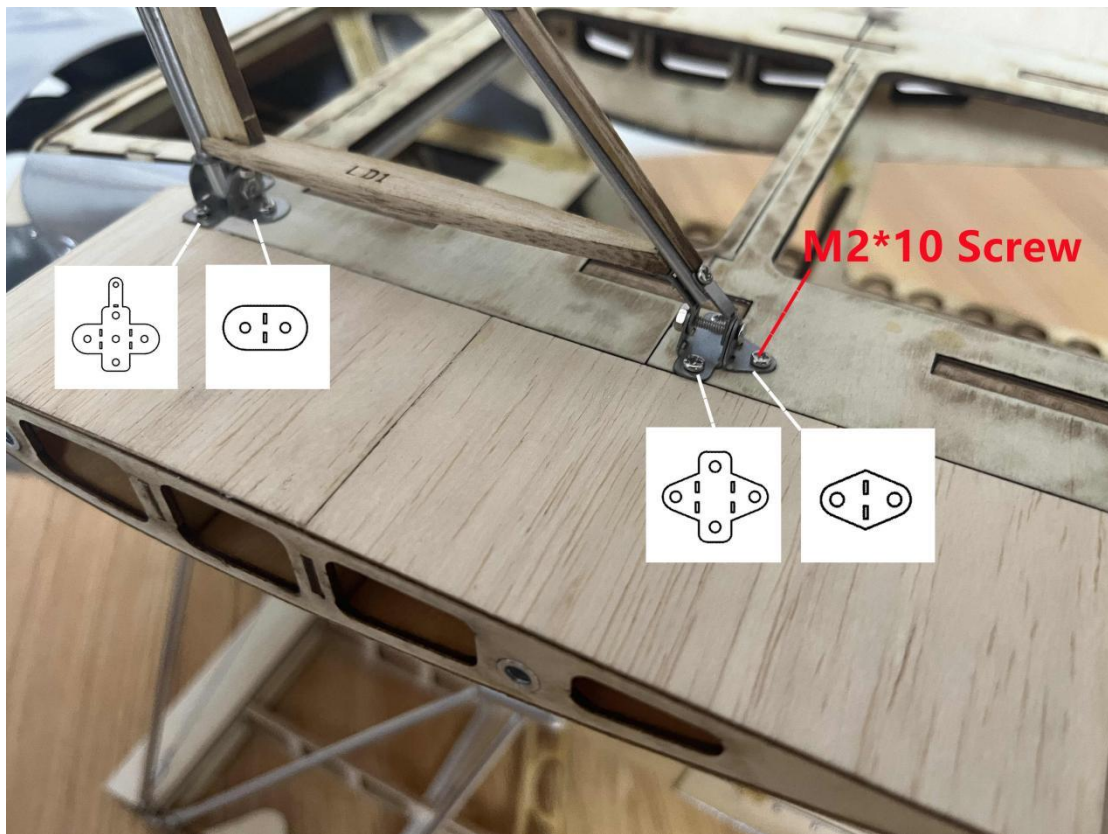

Step 11

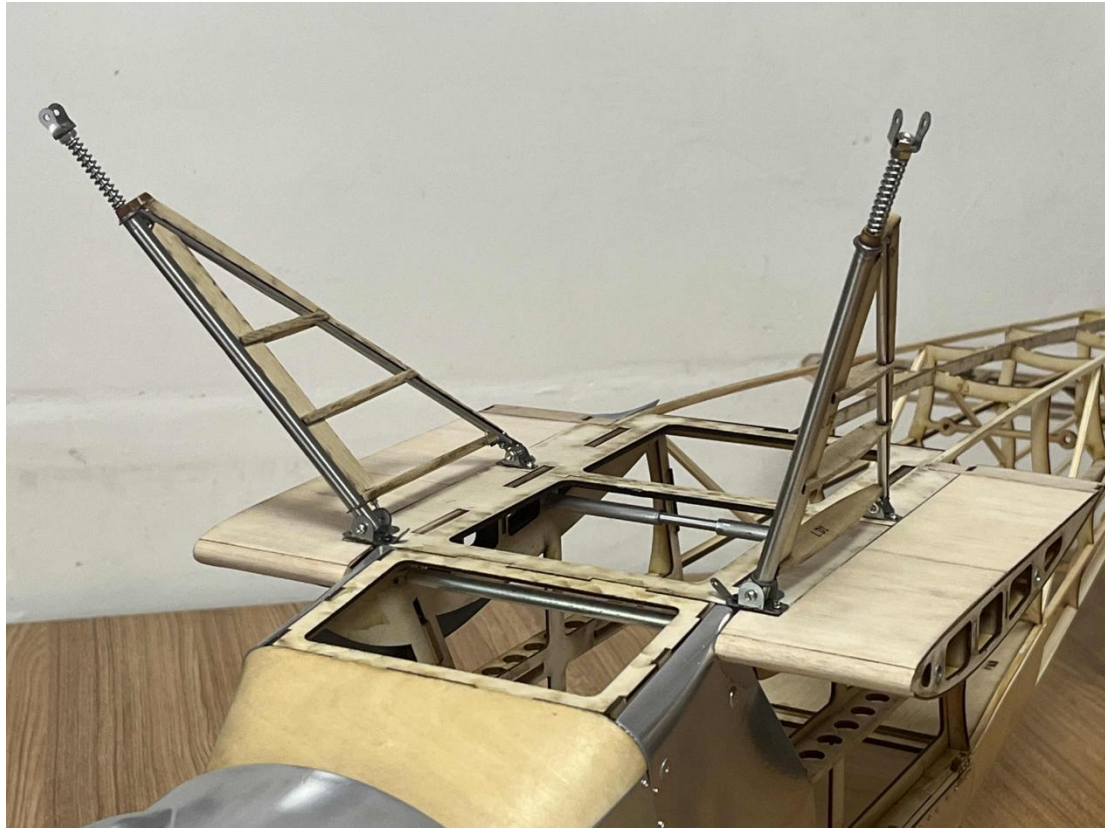

Step 12



Step 13

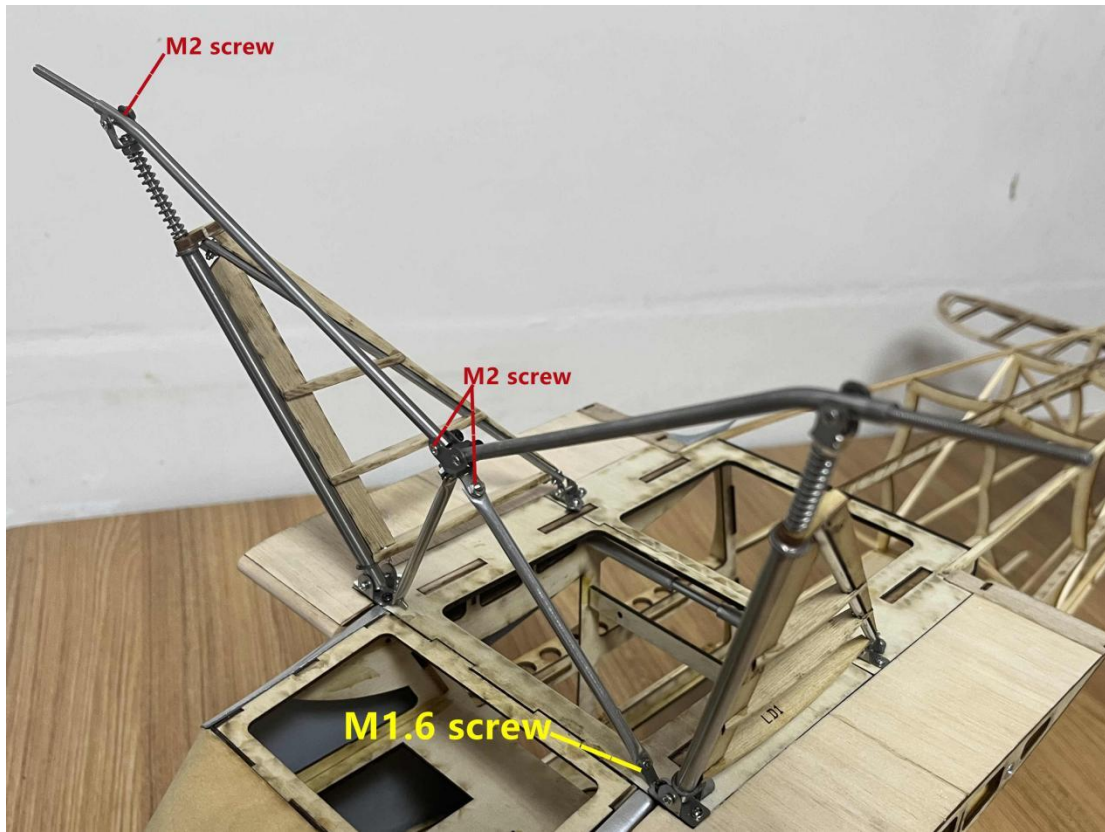

Step 14

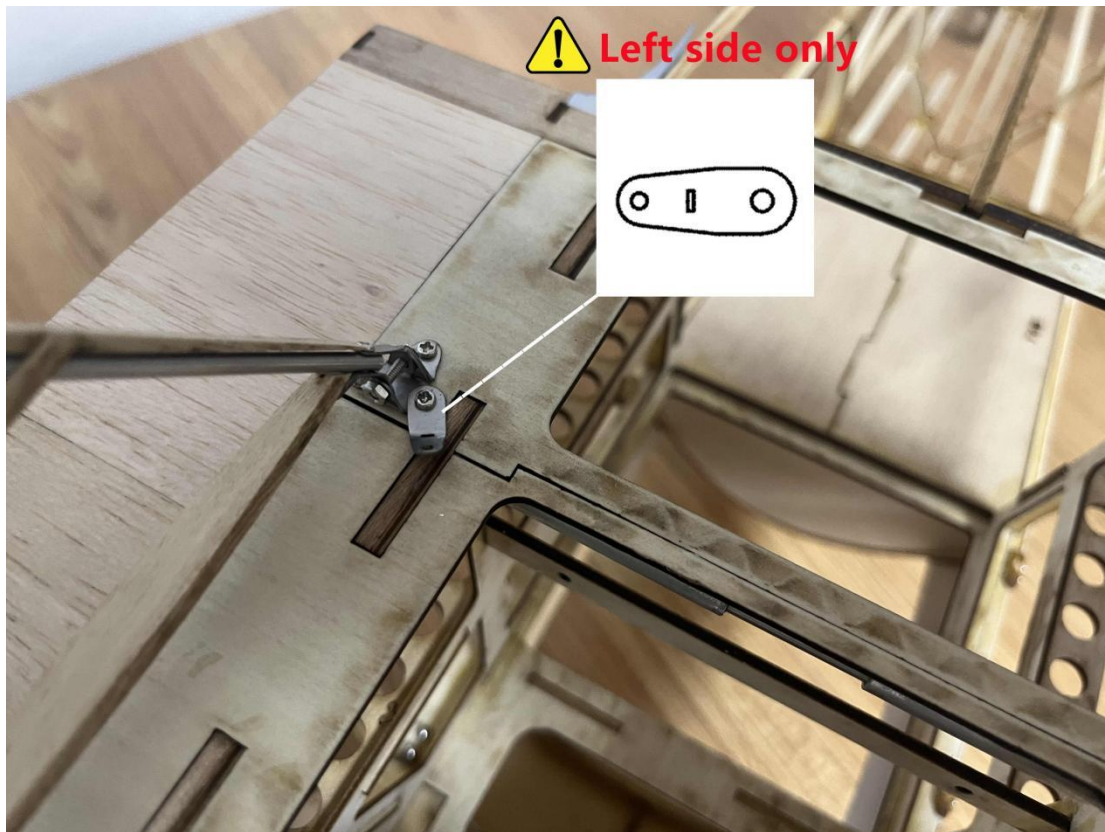

Step 15

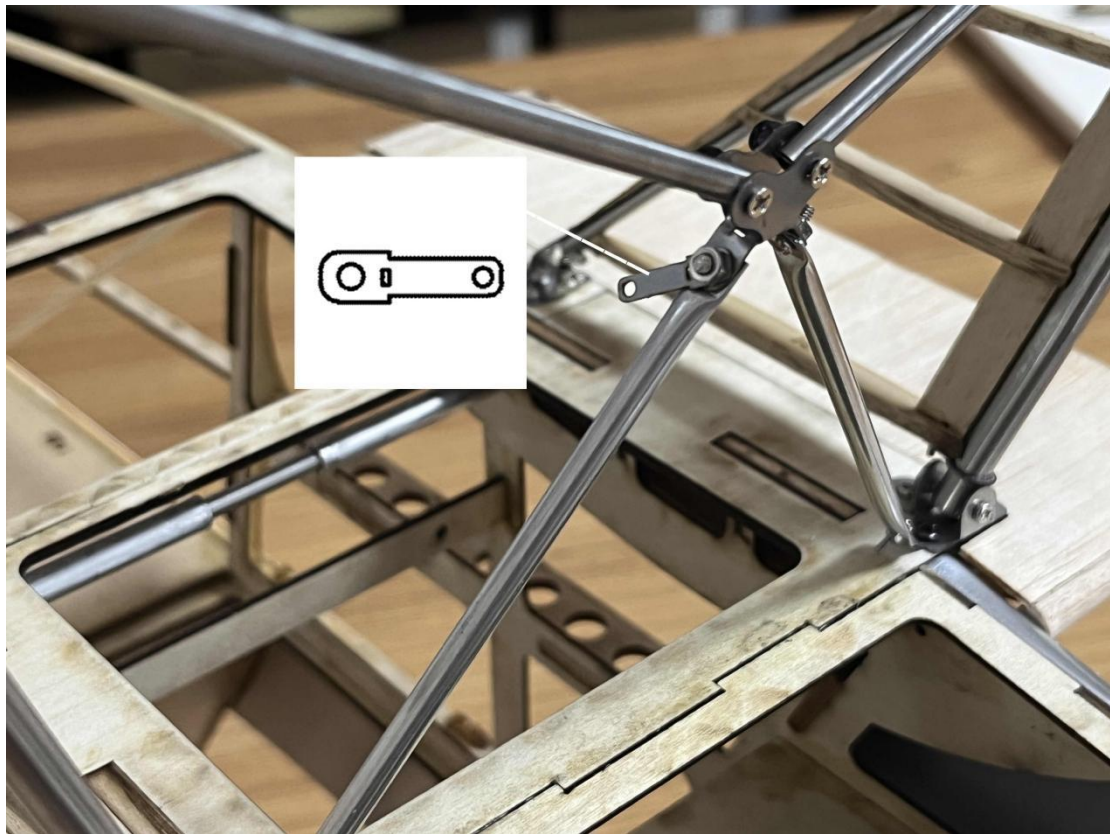

Step 16

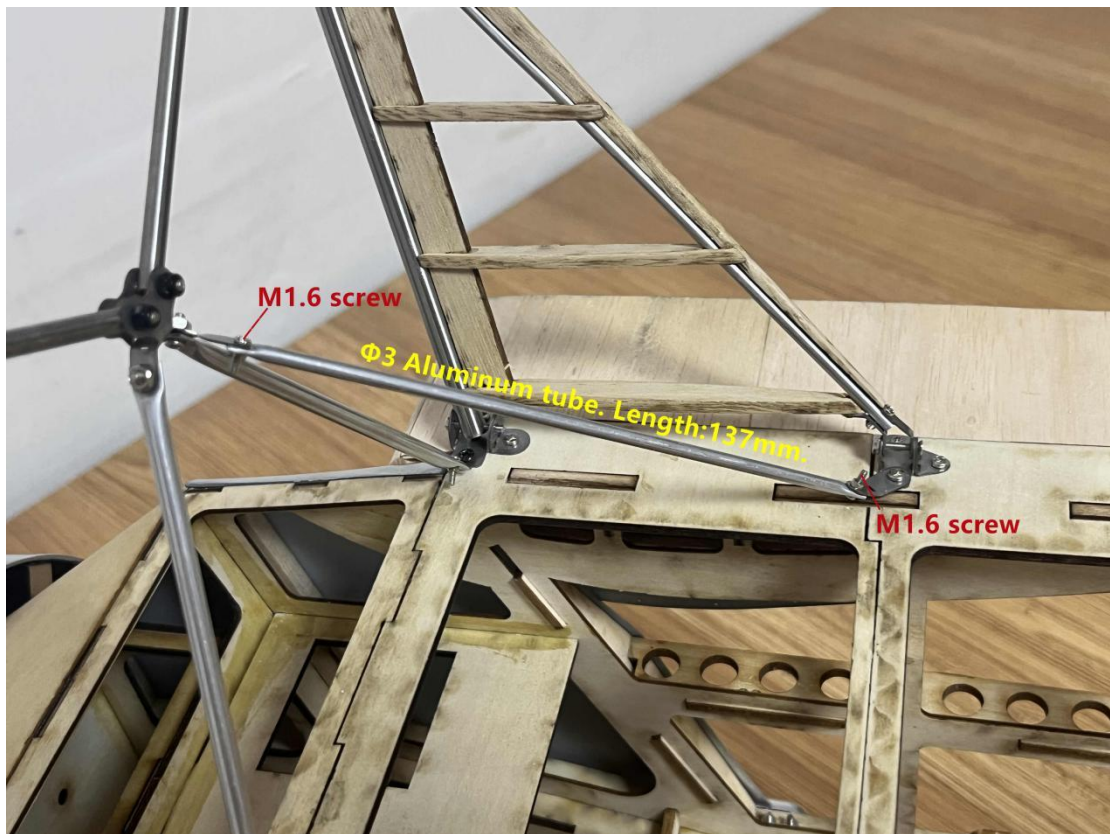

Step 17

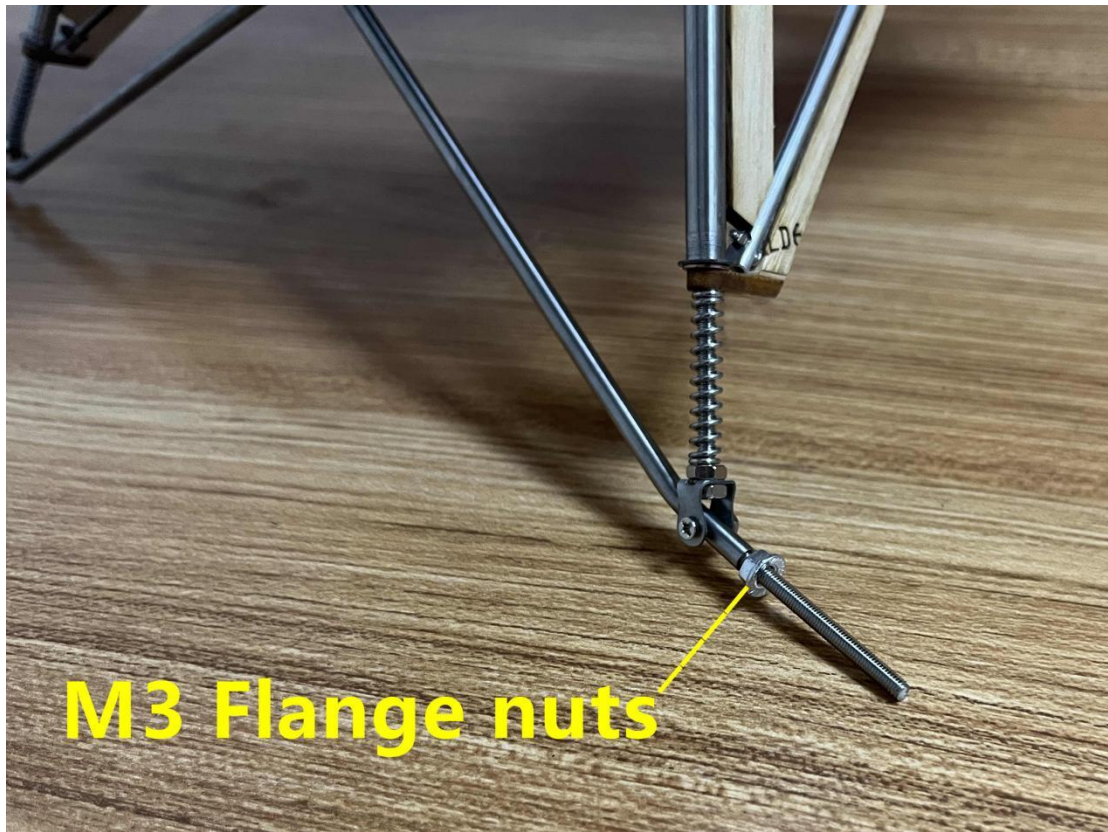

Step 18



6.ASSEMBLY-Cowl

Step 1



Step 2



Step 3



Step 4

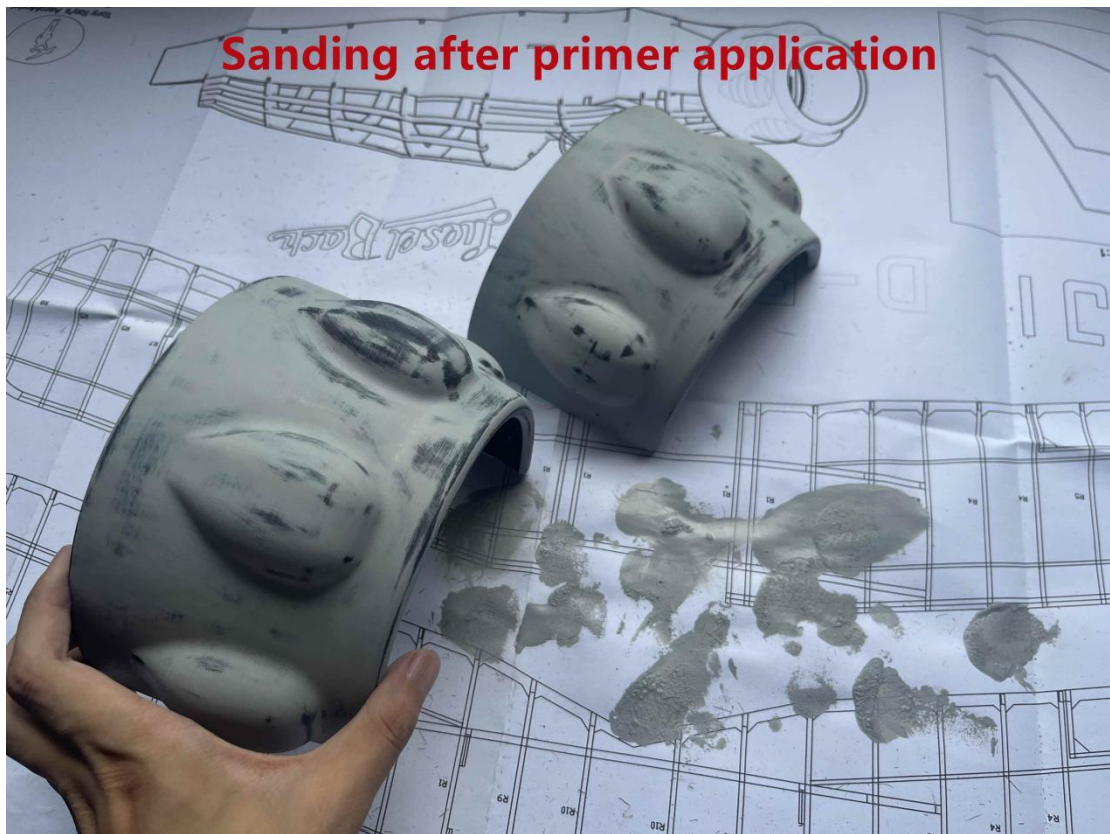

Step 5



Step 6

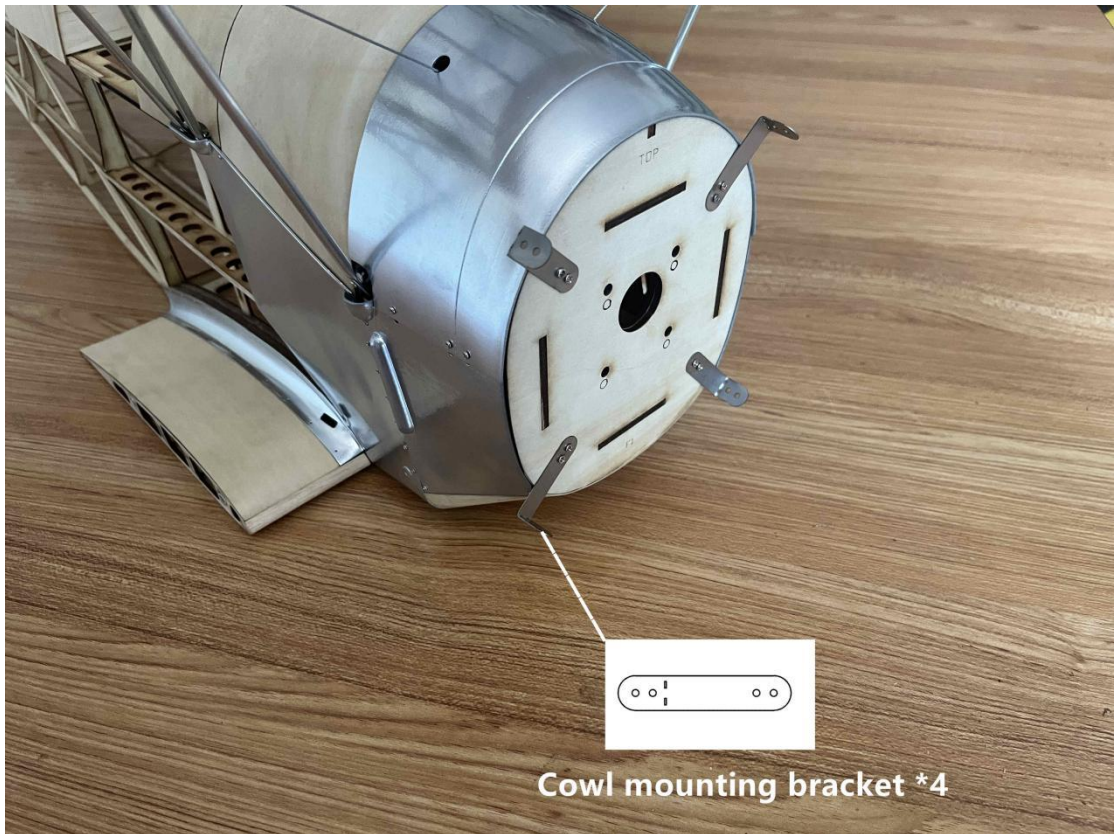

Cowl mounting bracket *4

7.ASSEMBLY-*Bottom Wings*

Step 1

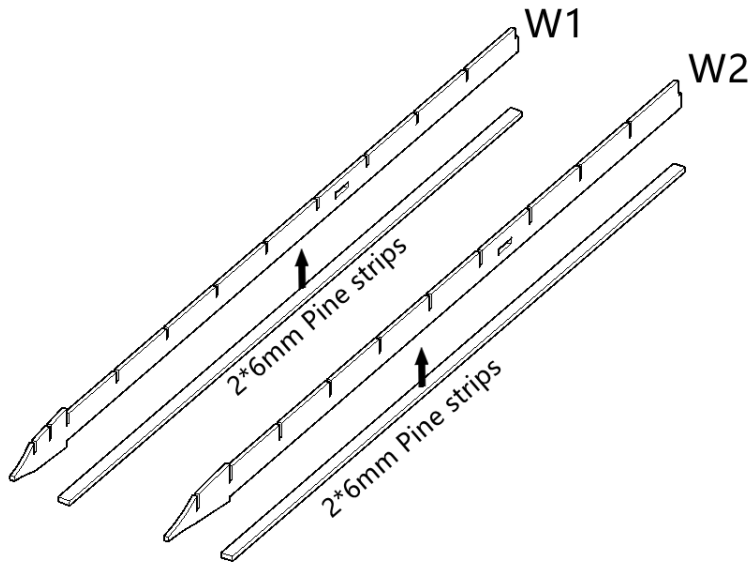

Step 2

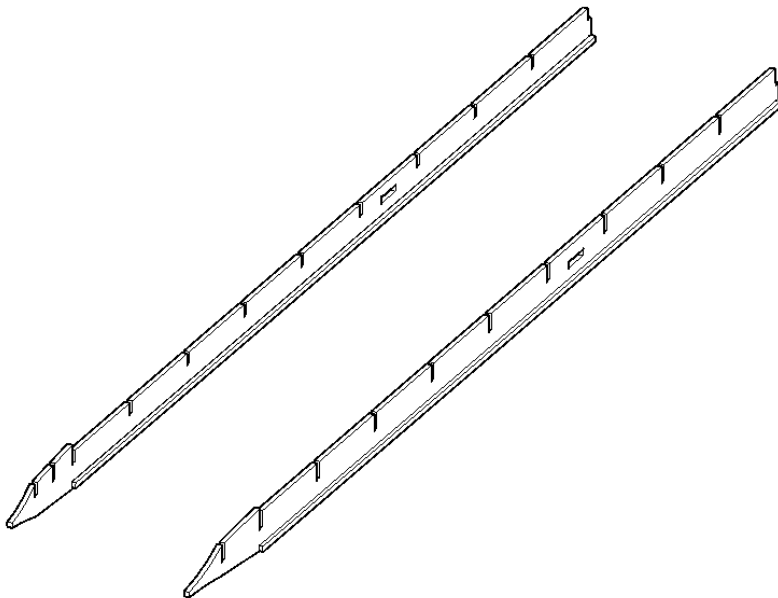

Step 3

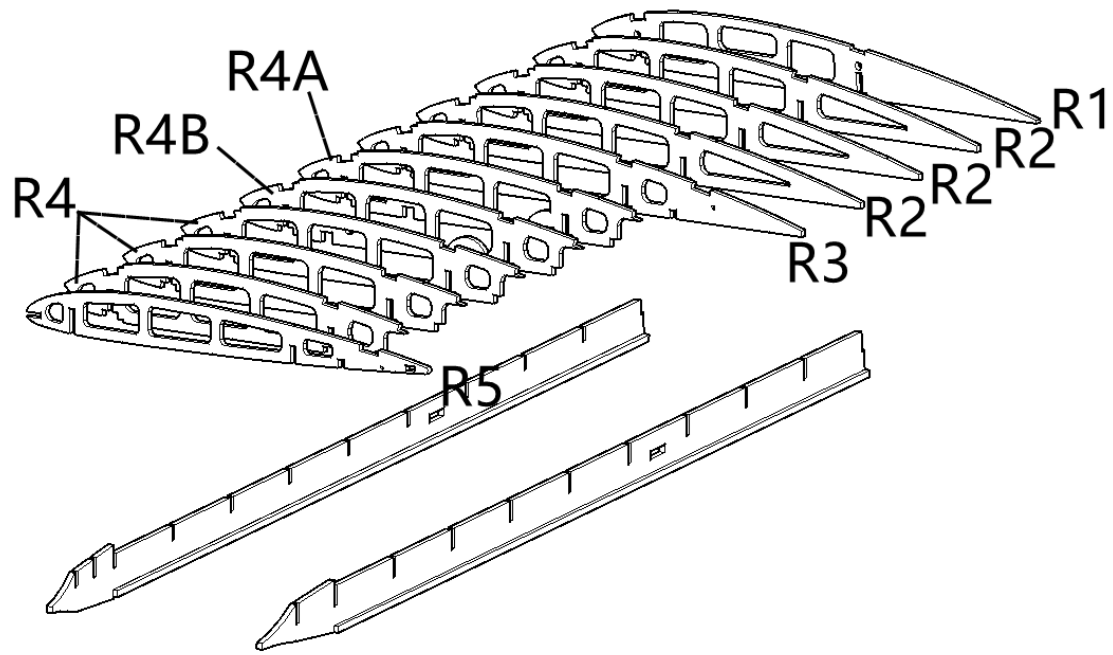

Step 4

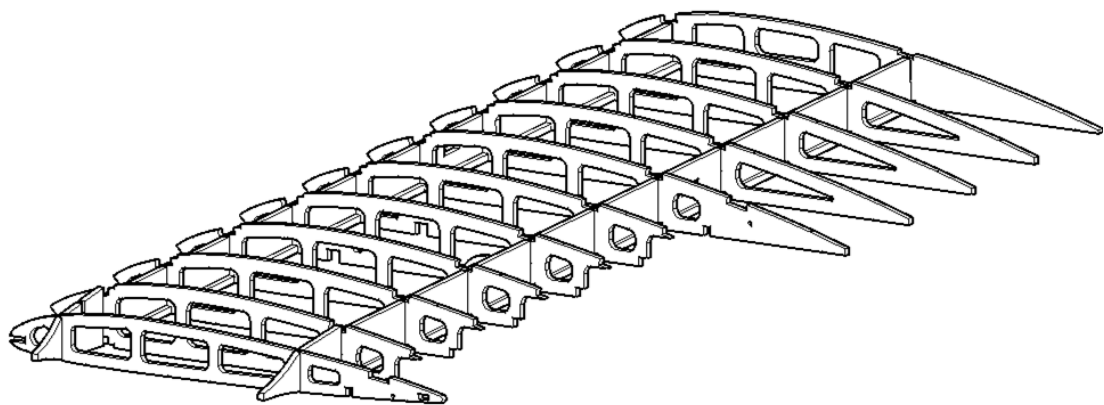

Step 5

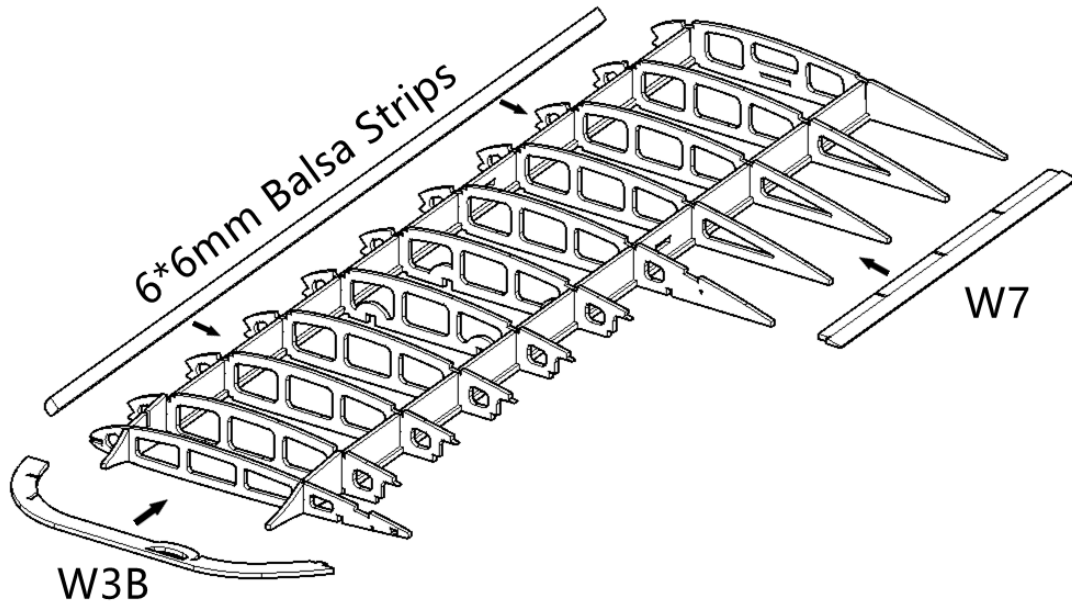

Step

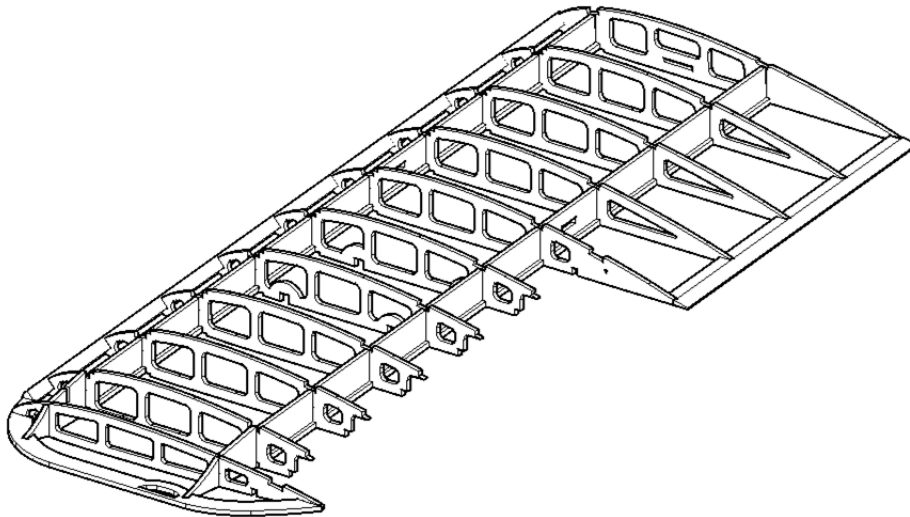

Step 7

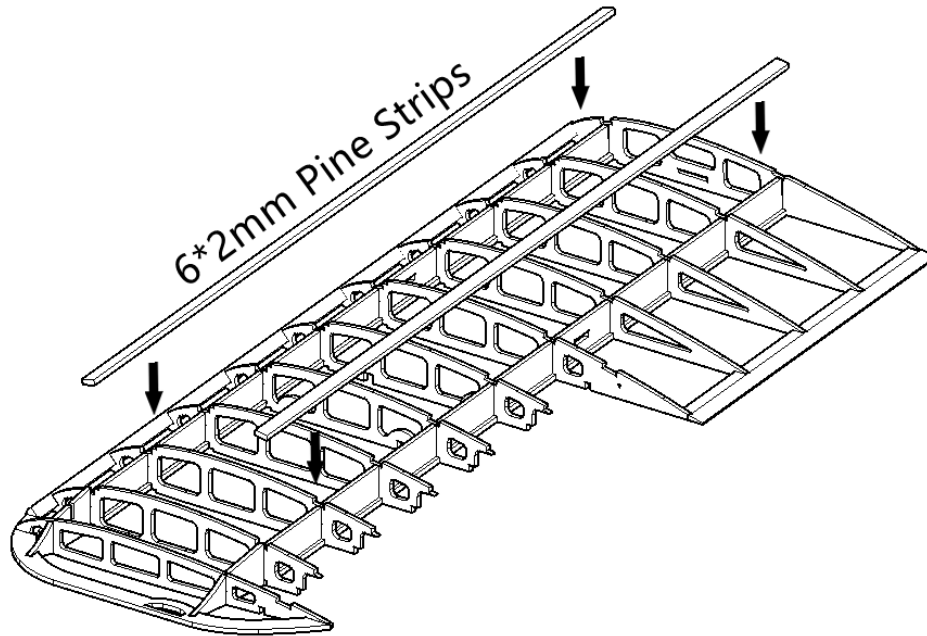

Step 8

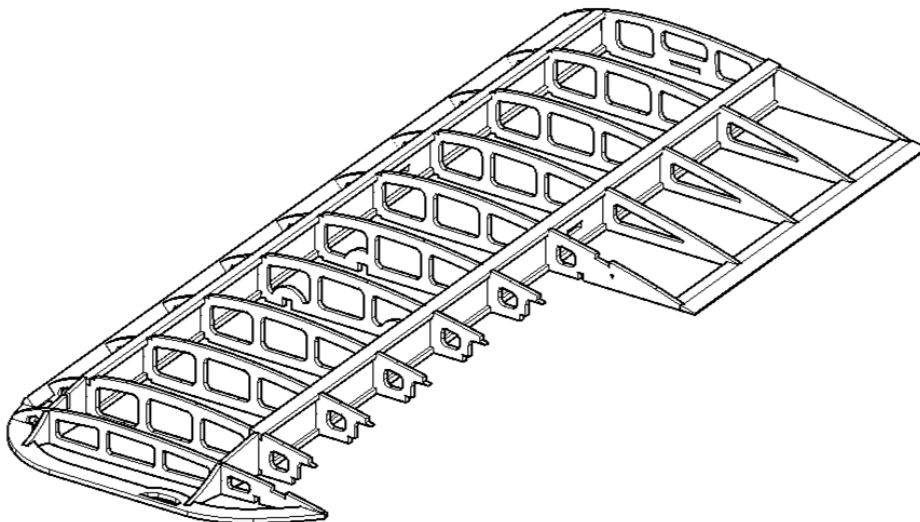

Step 9

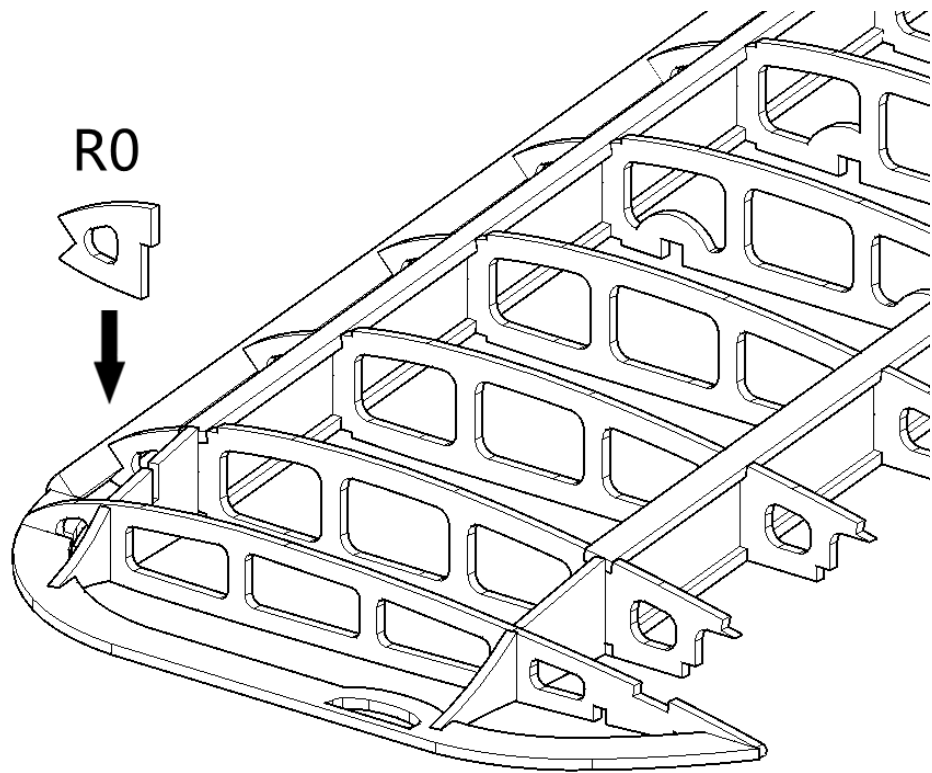

Step 10

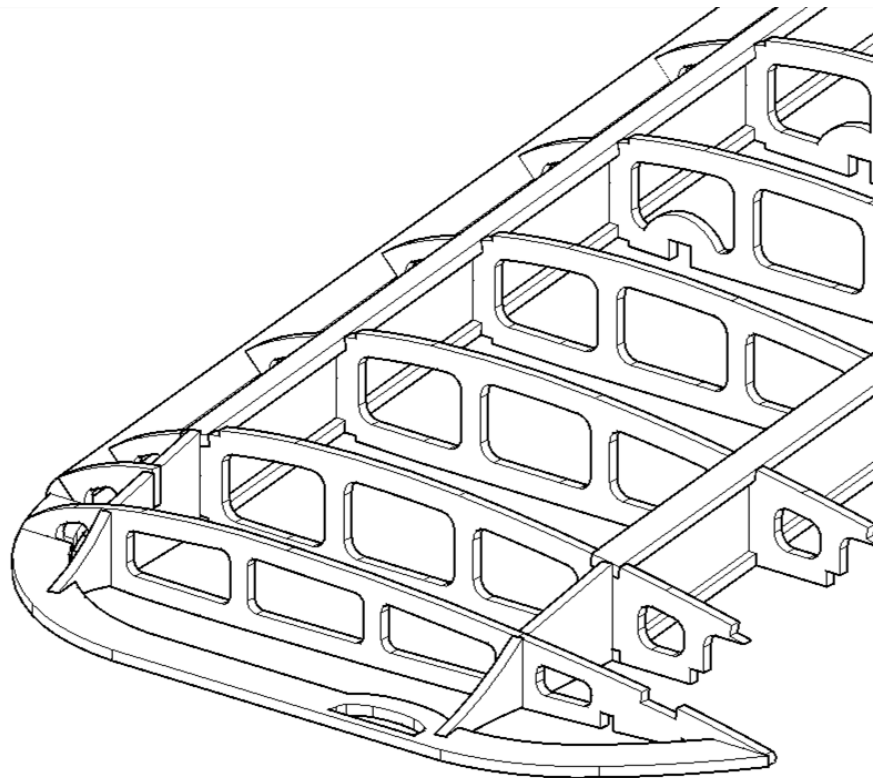

Step 11

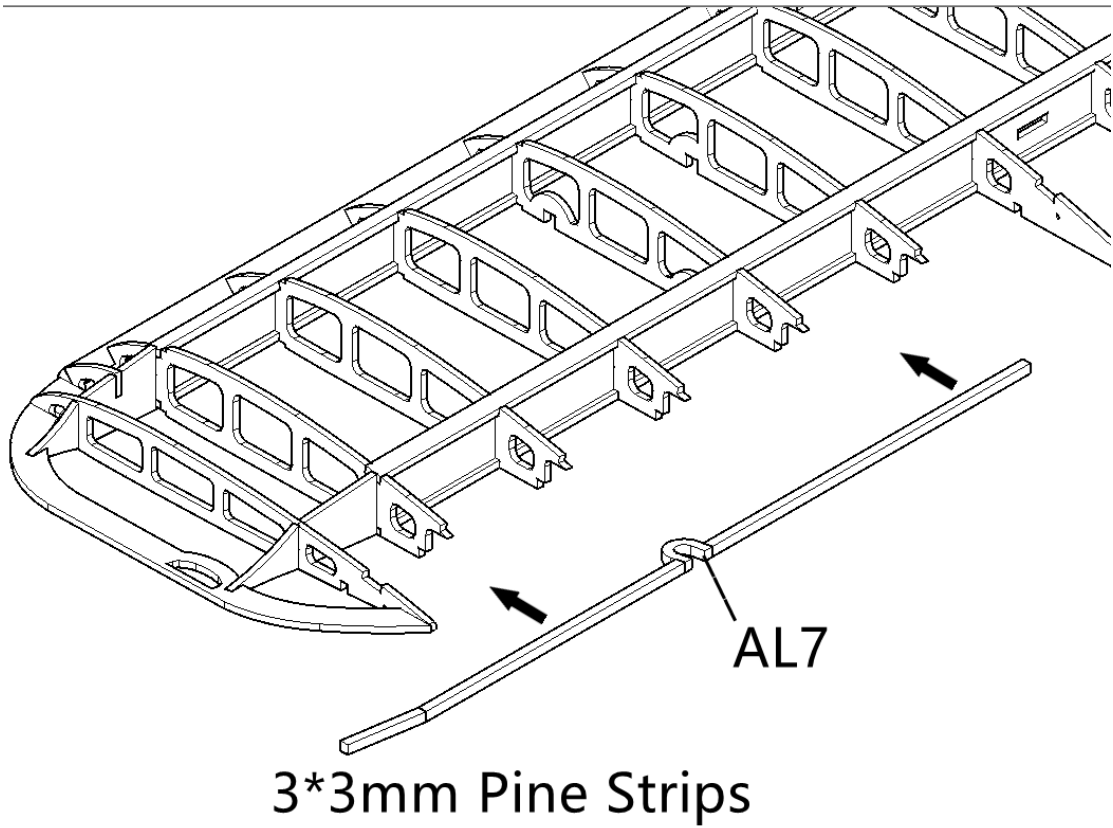

Step 12

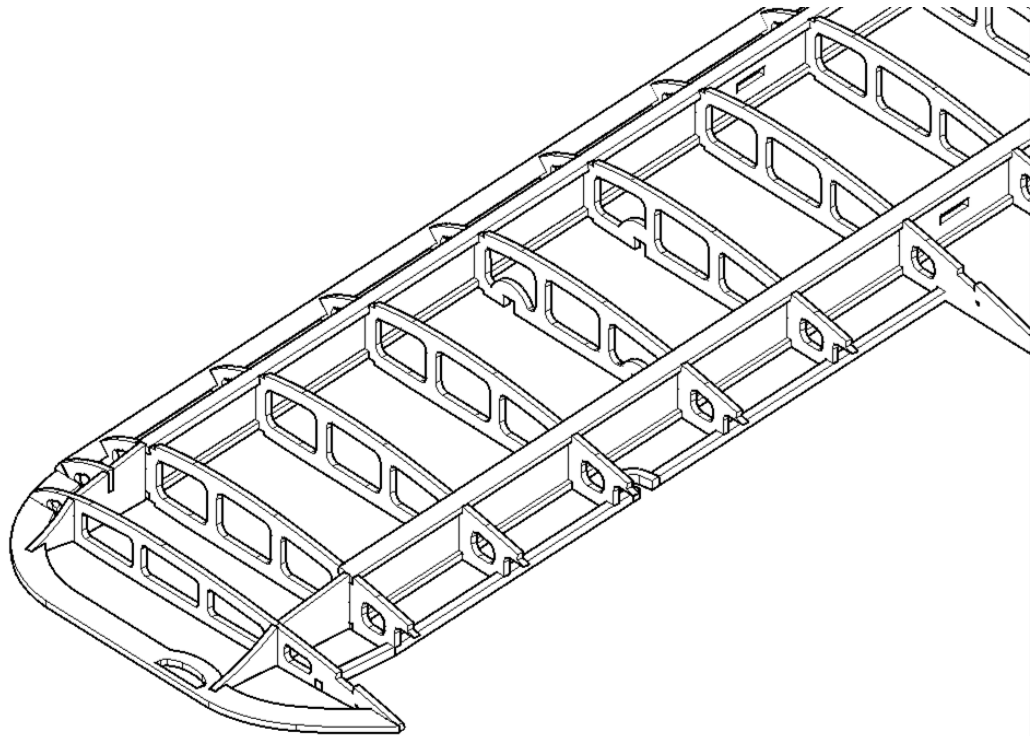

Step 13

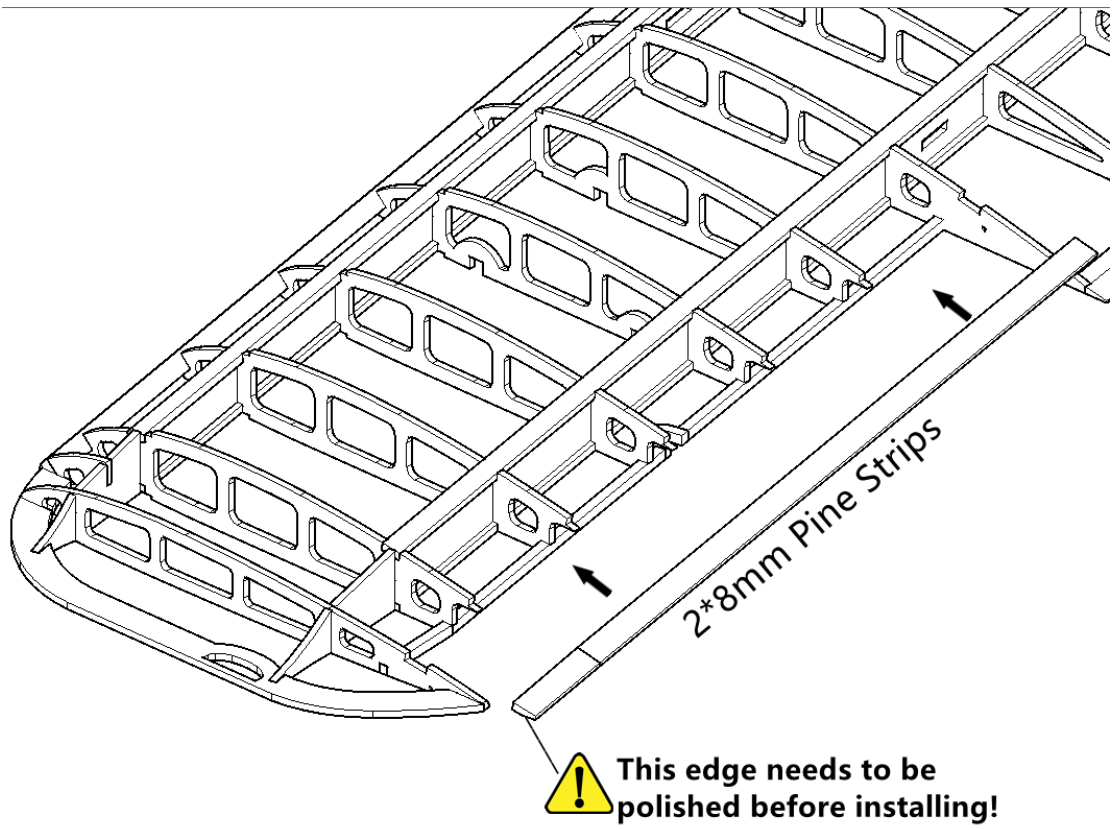

Step 14

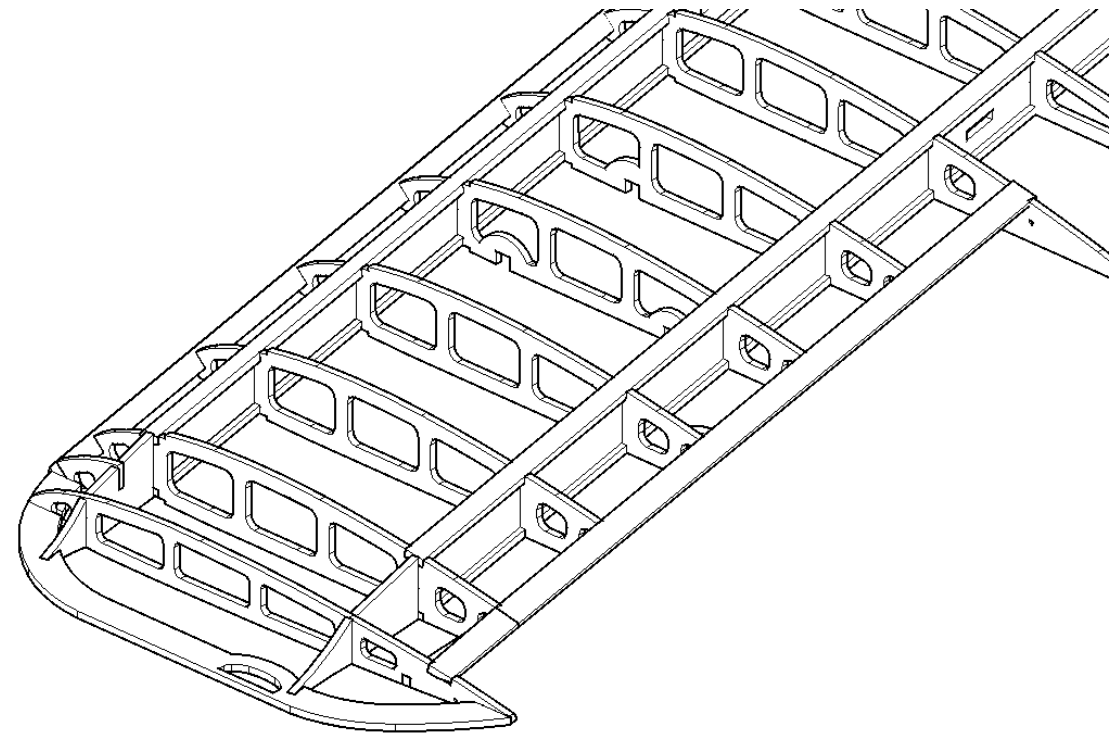

Step 15

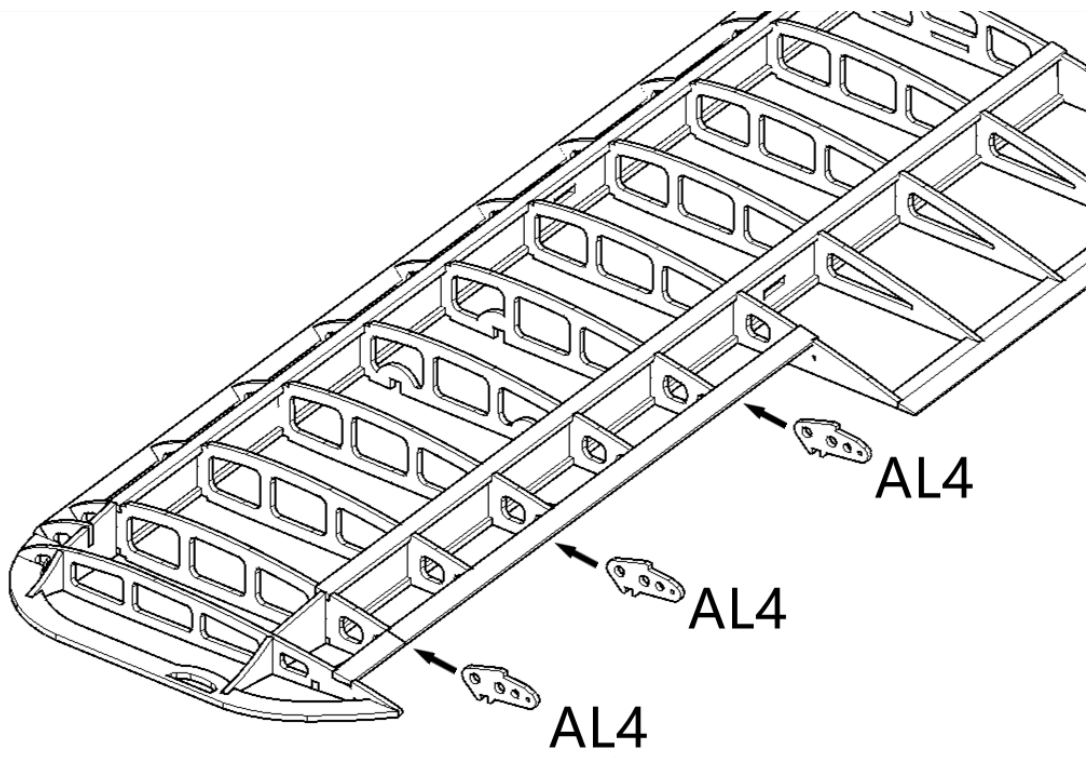

Step 16

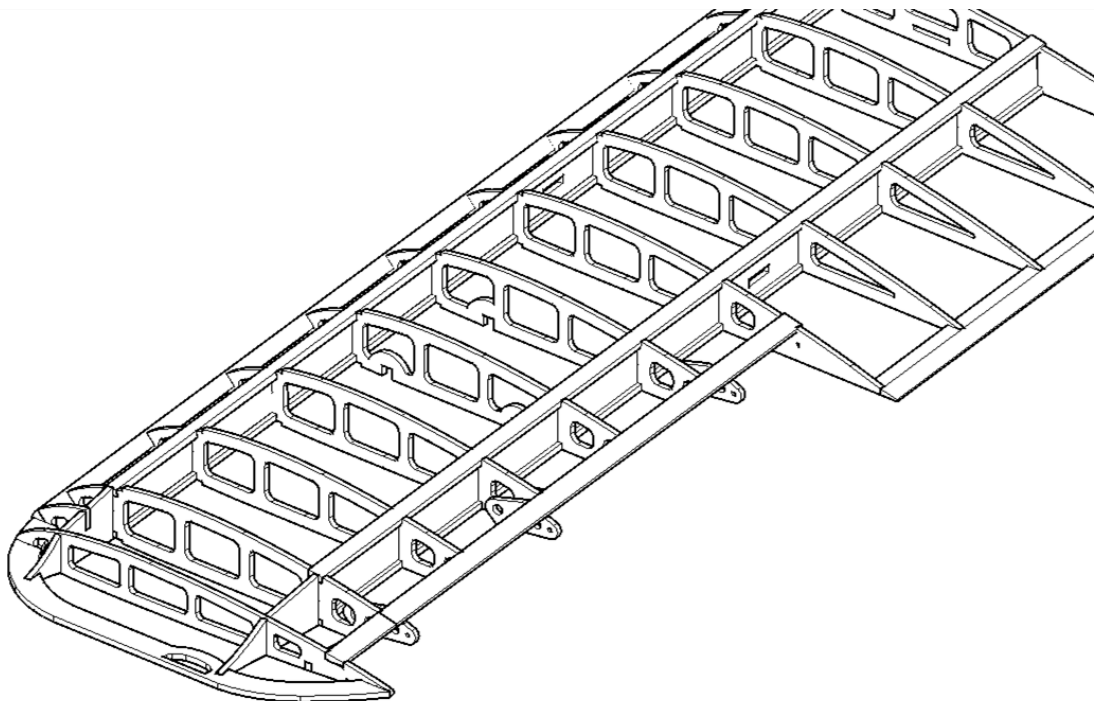

Step 17

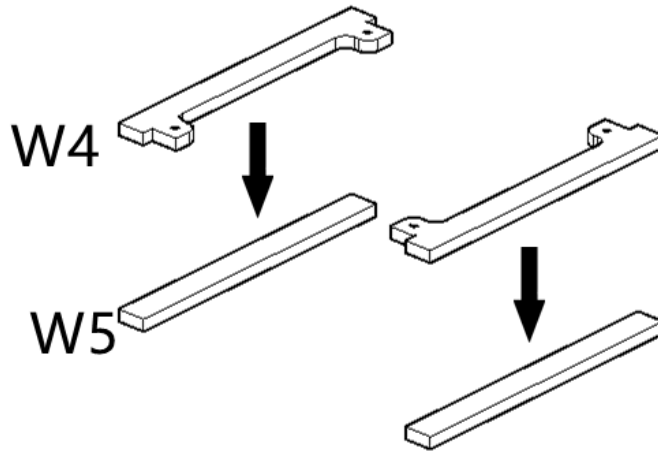

Step 18

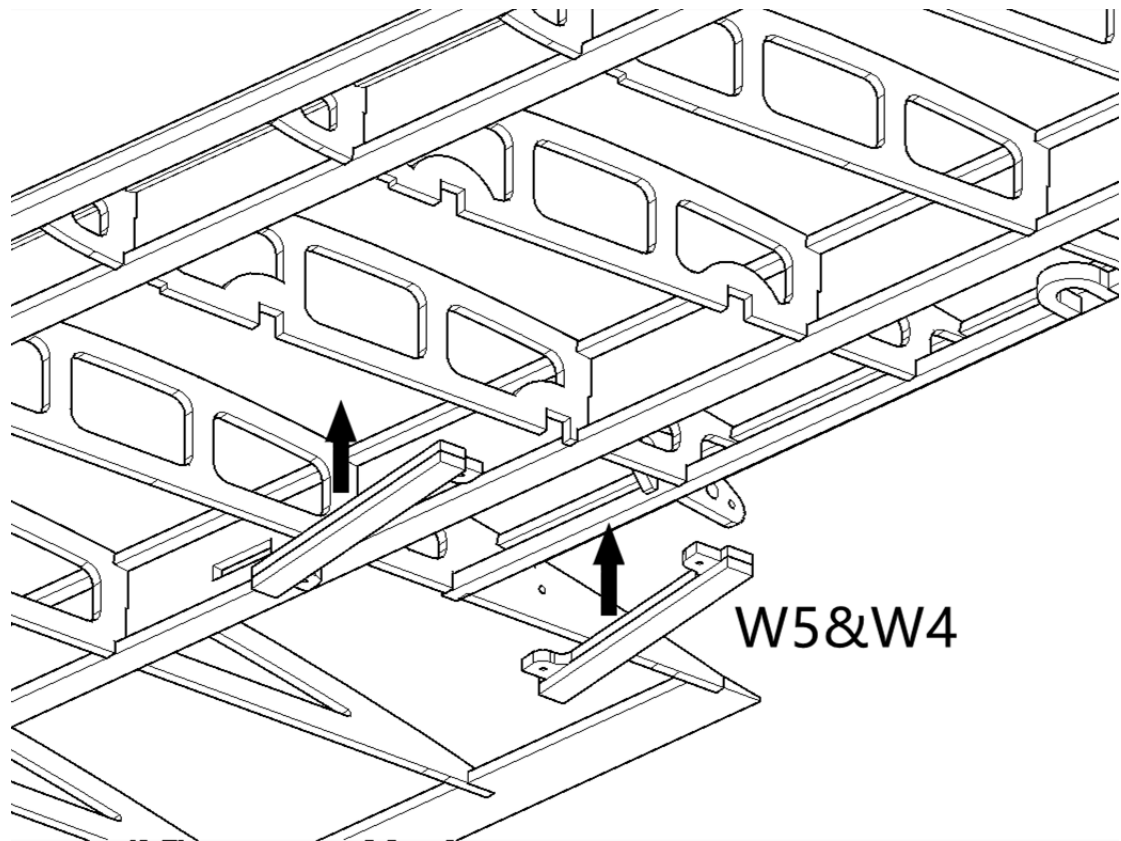

Step 19

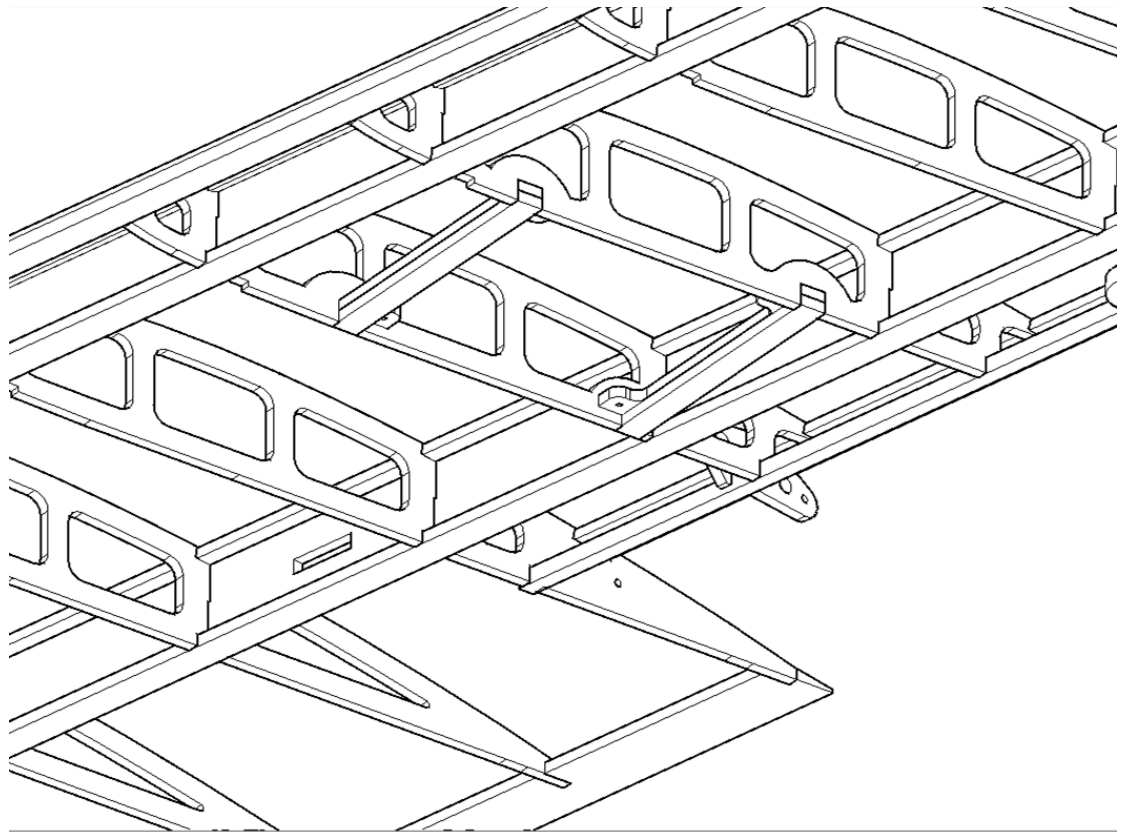

Step 20

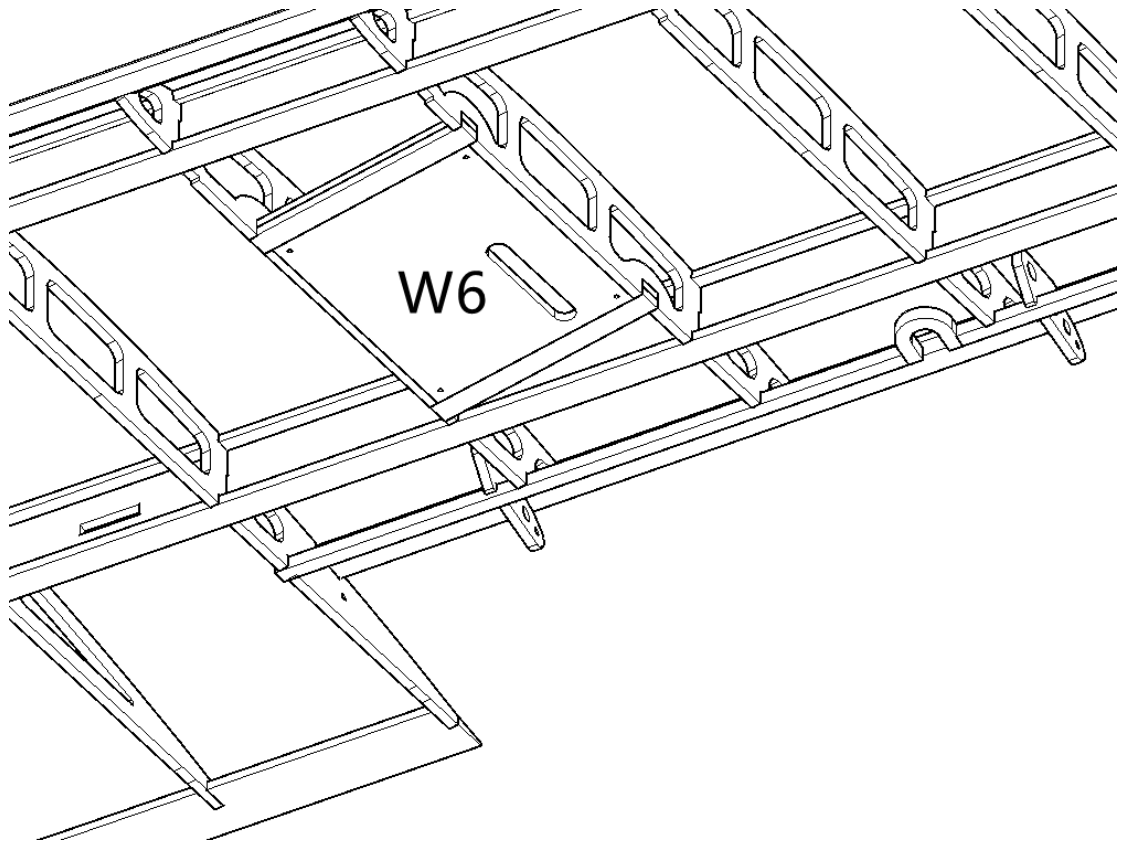

Step 21

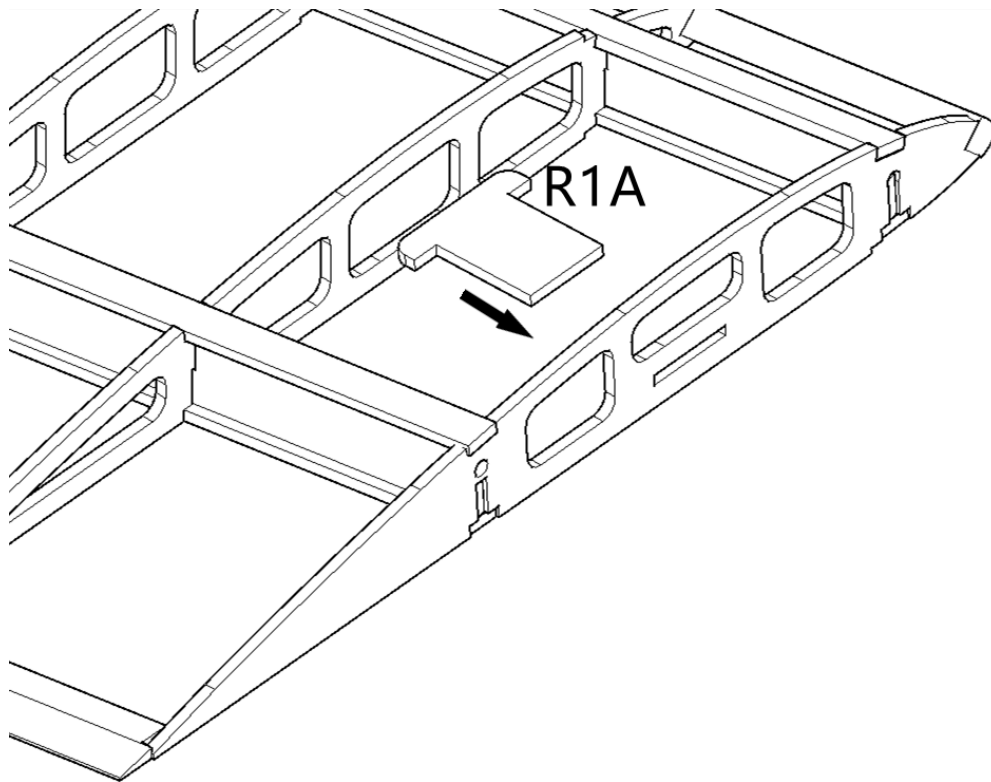

Step 22

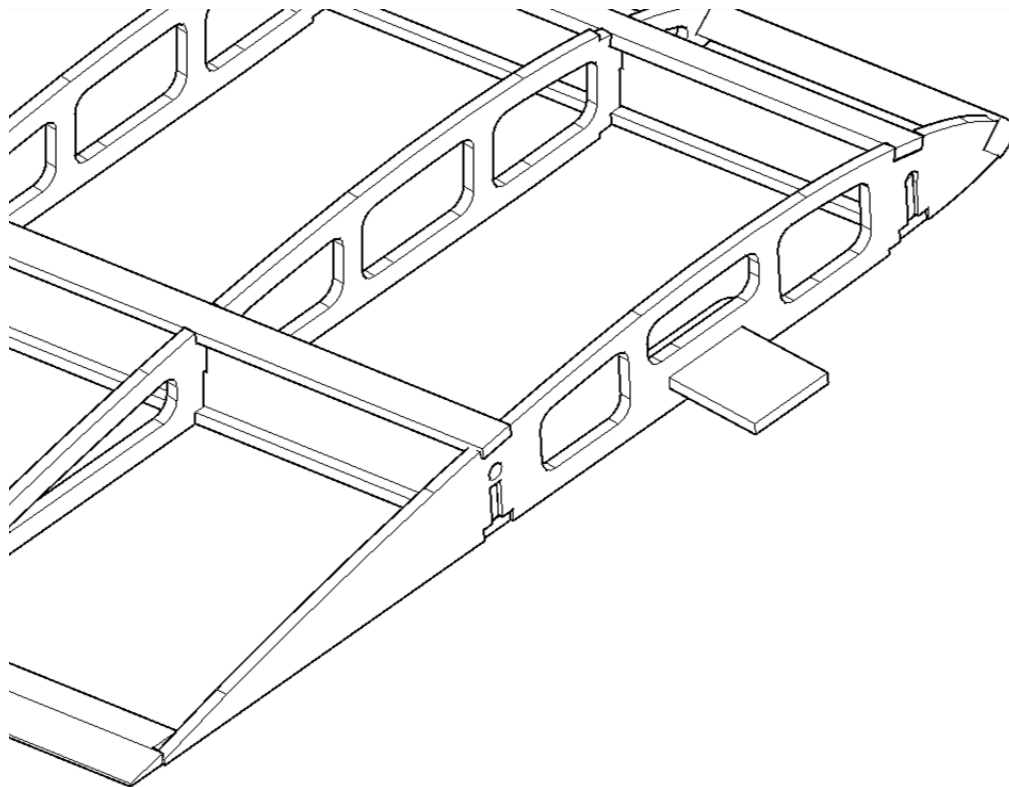

Step 23

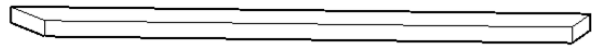
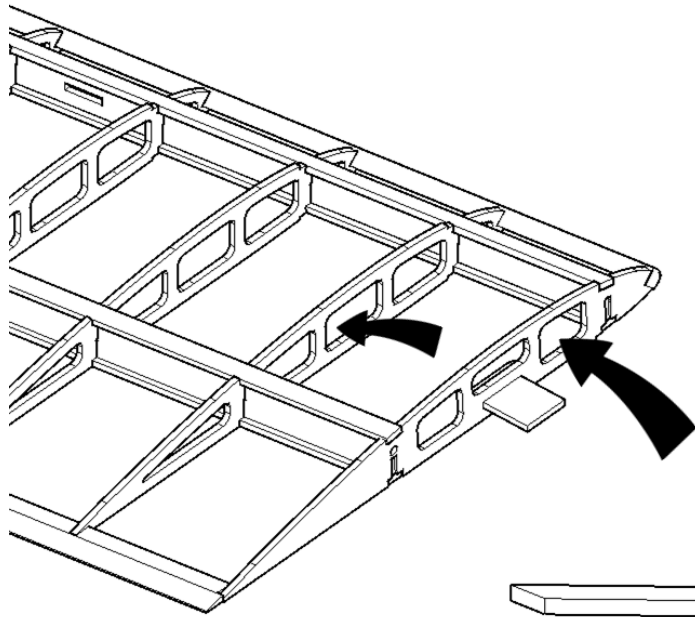

6*6mm Balsa Strips

Step 24

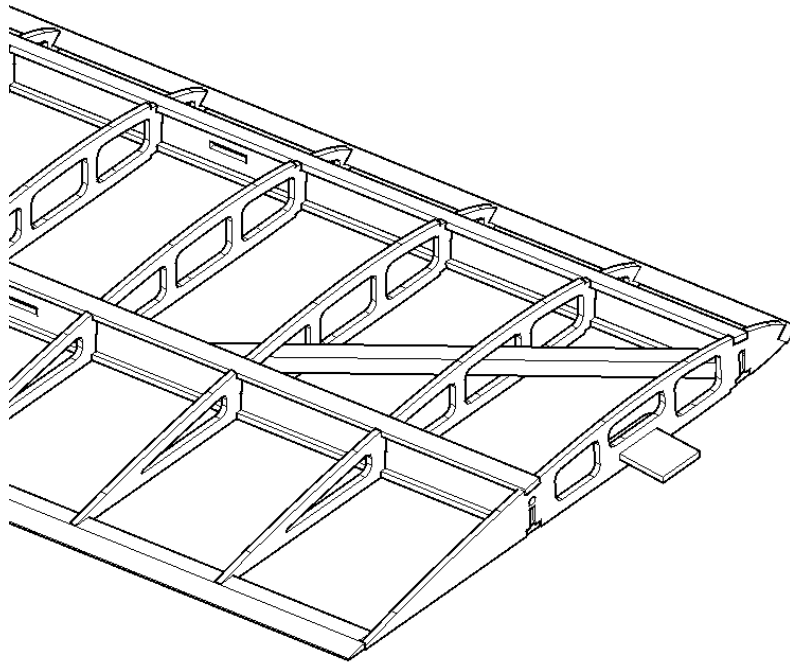

Step 25

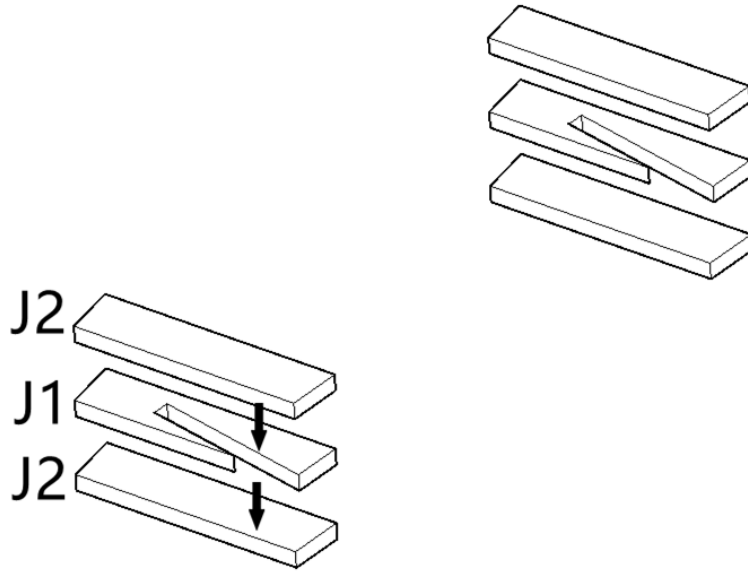

Step 26

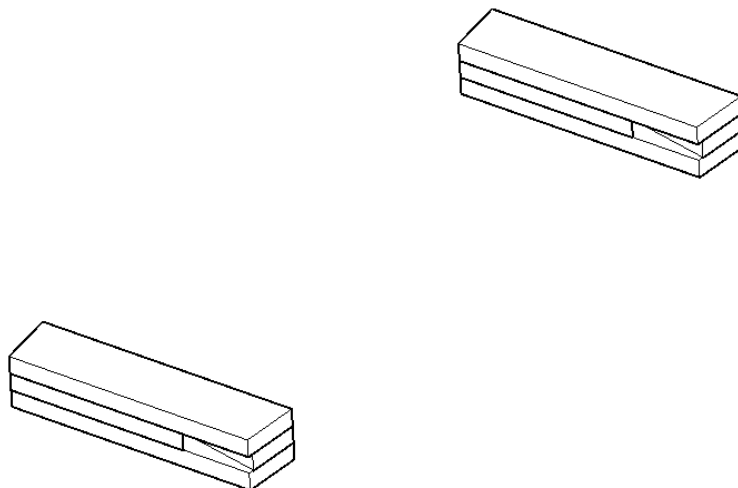

Step 27

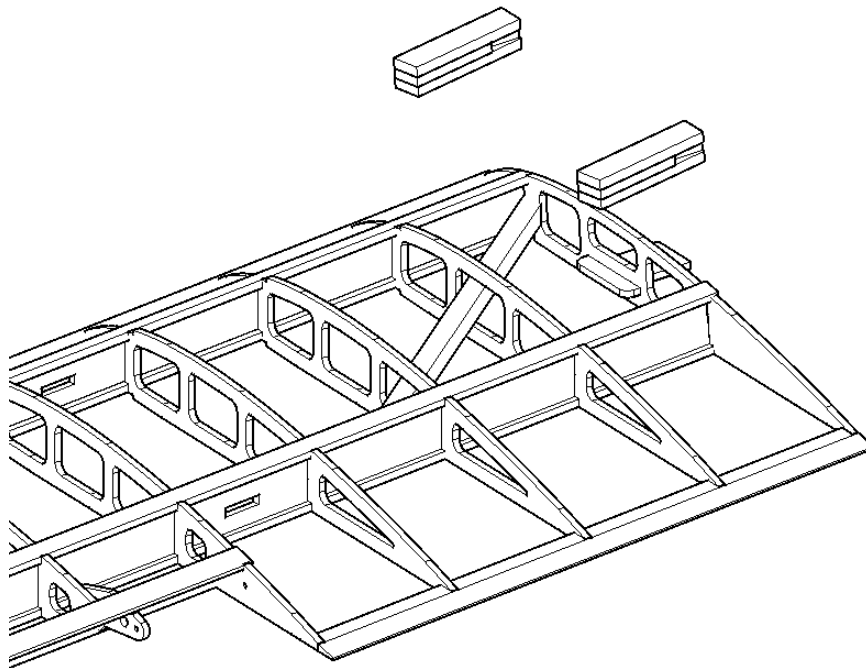

Step 28

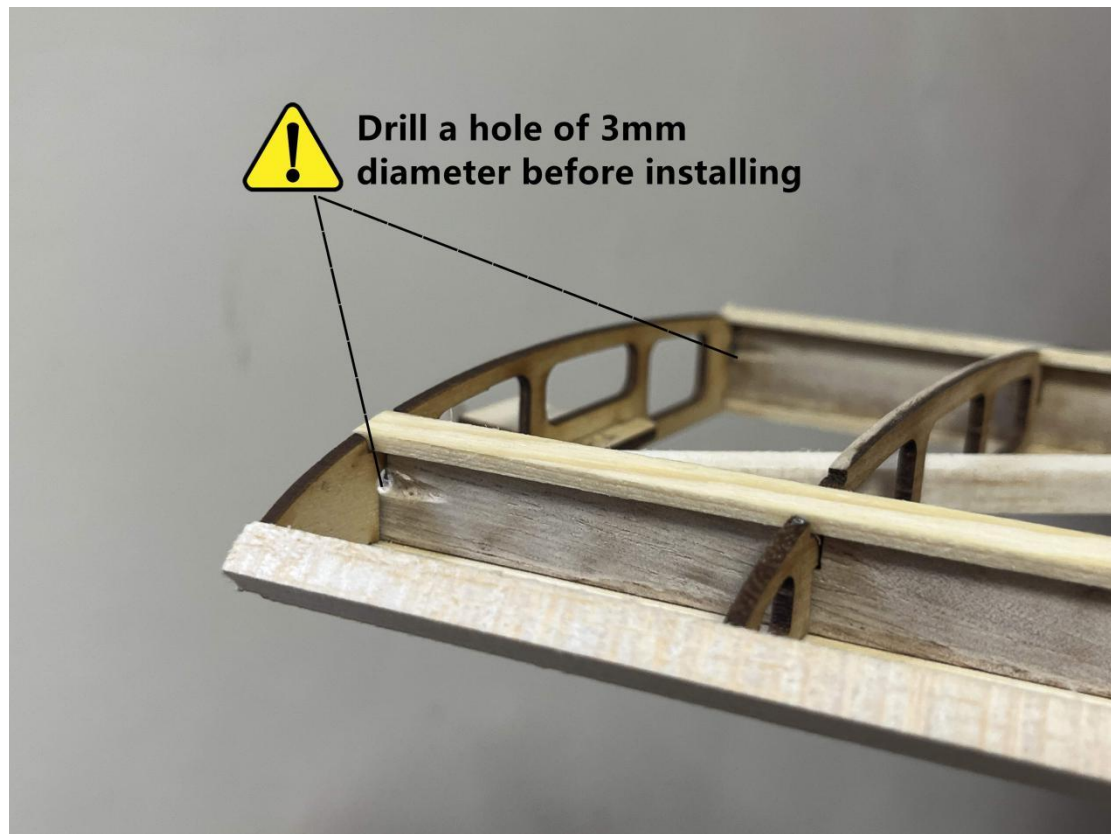

Step 29

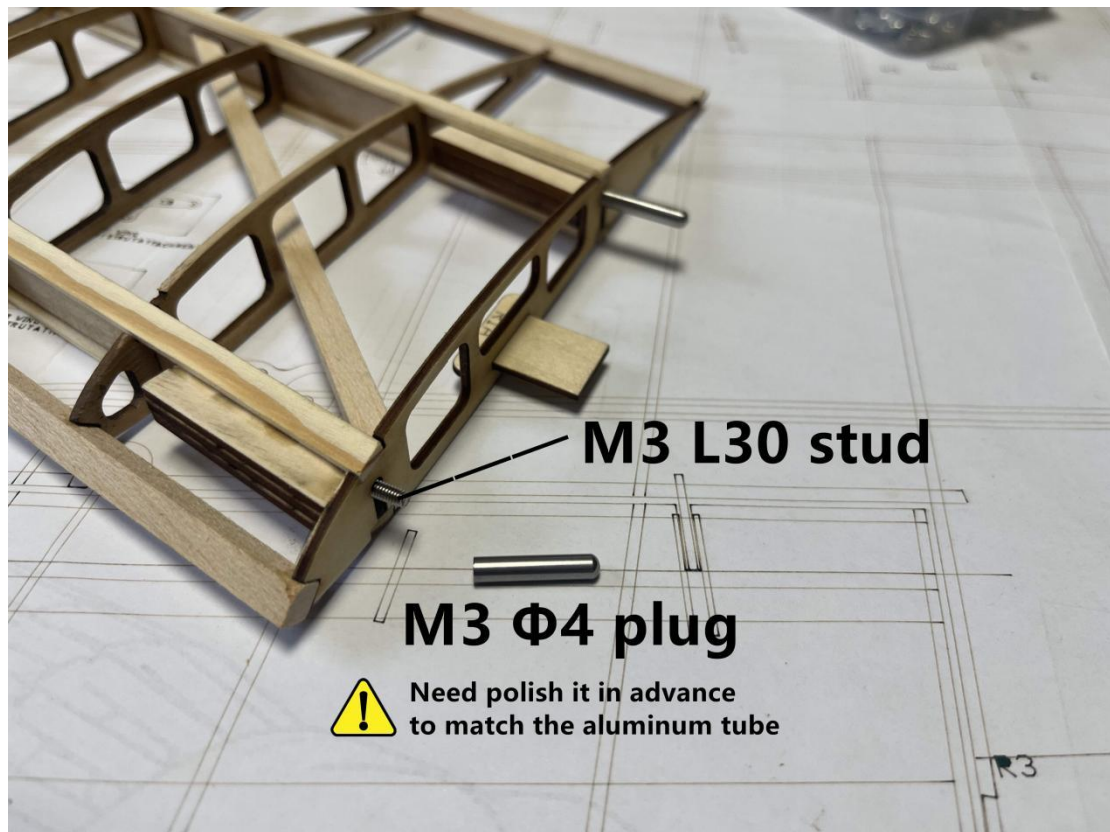

Step 30

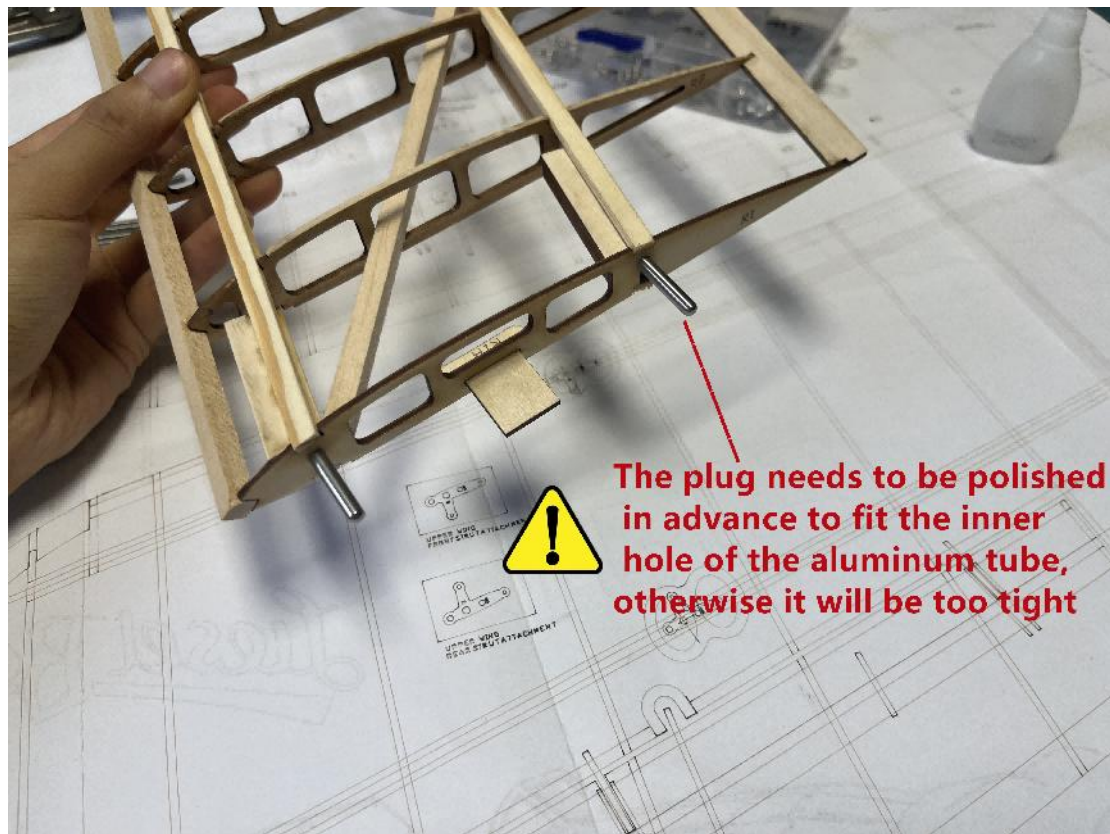

Step 31

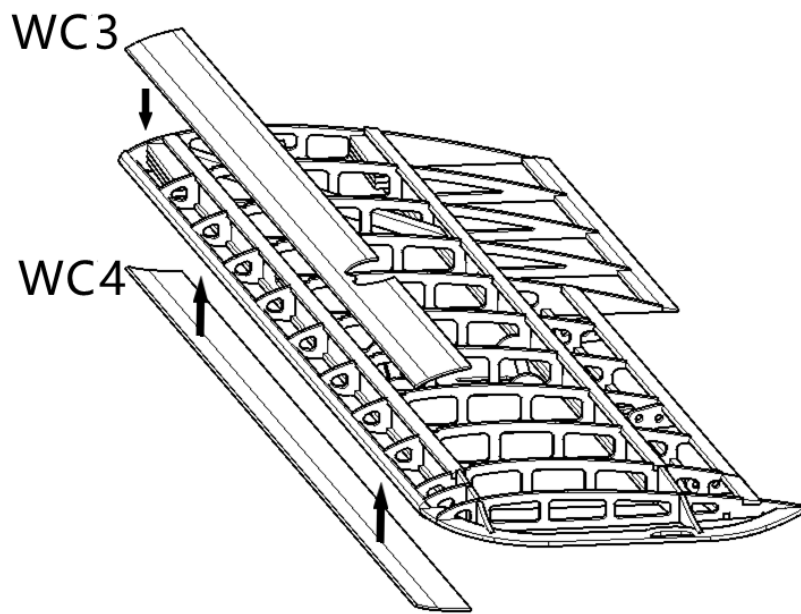

Step 32

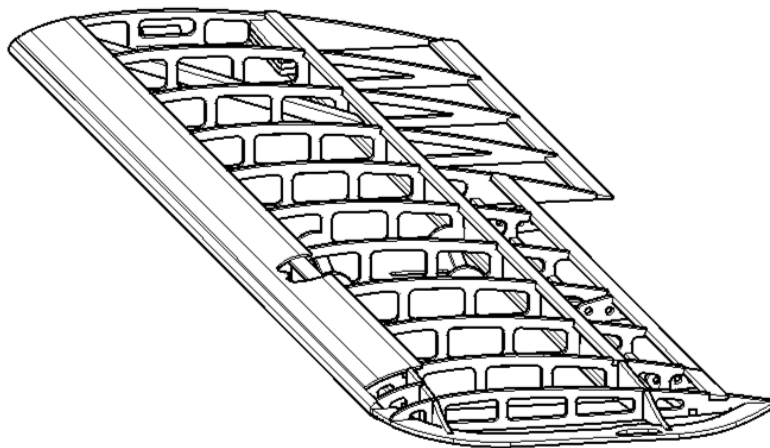

Step 33

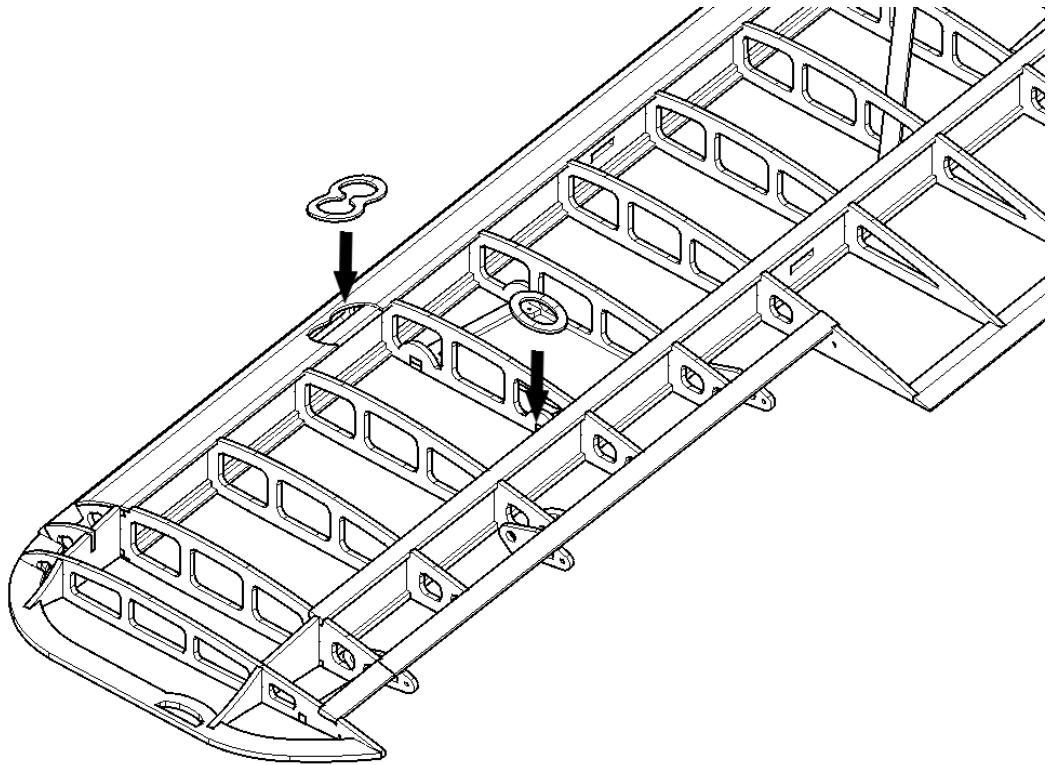

Step 34

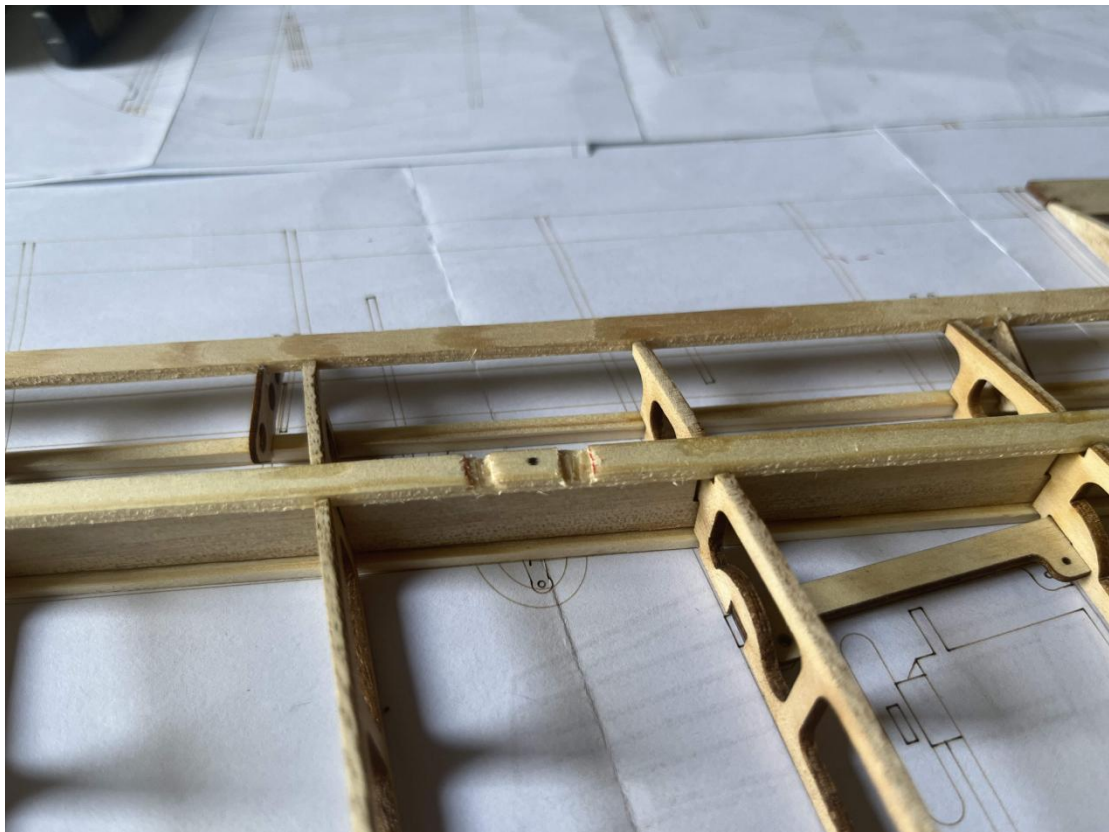

Step 35

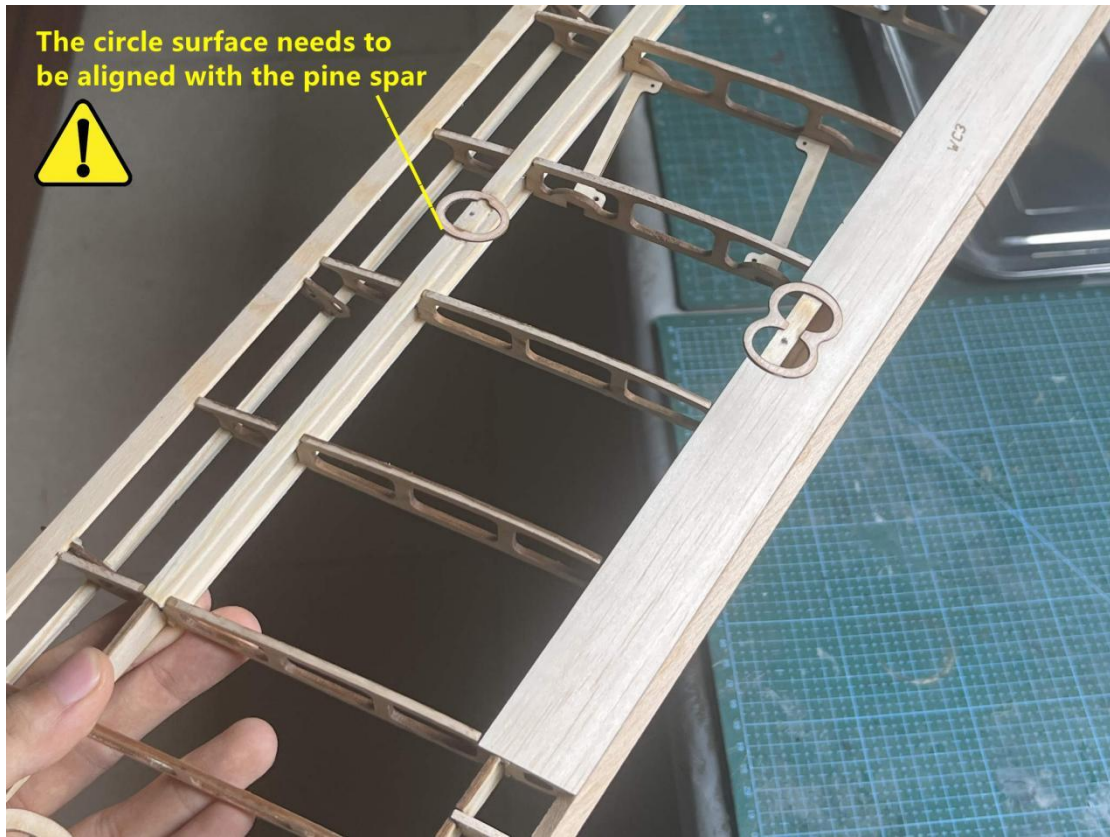

Step 36



Step 37

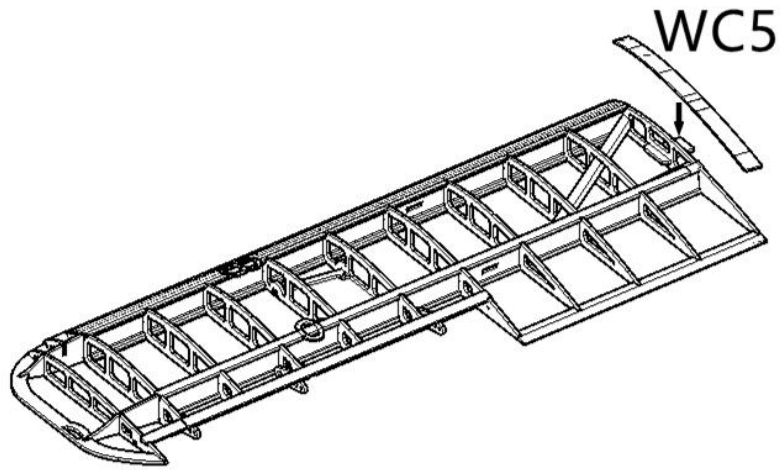

Step 38

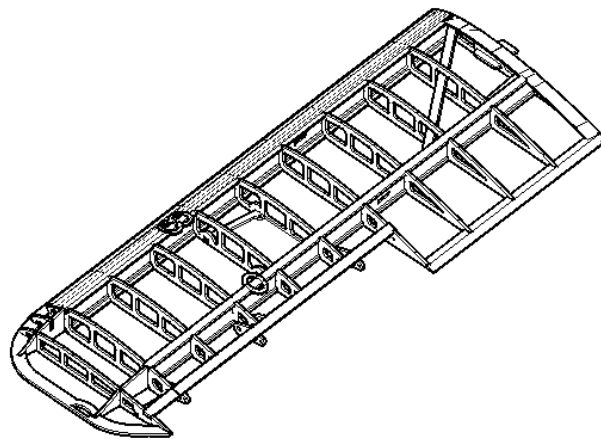

Step 39

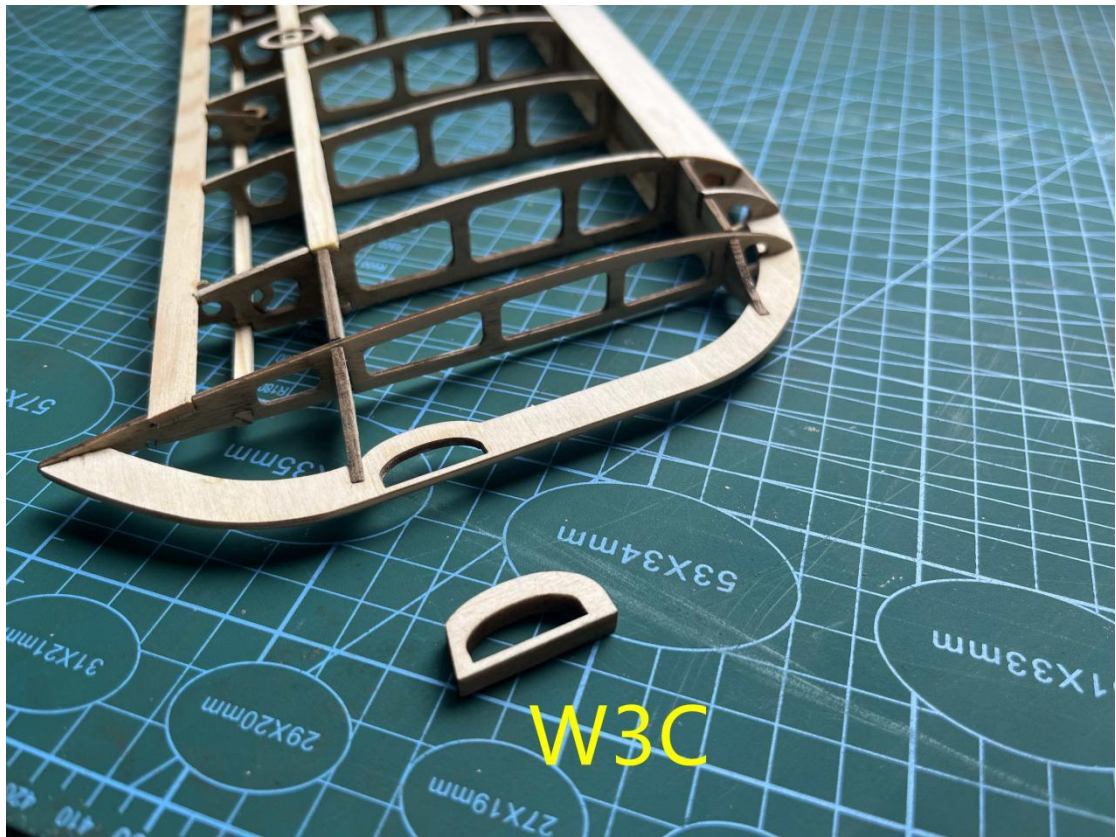

Step 40

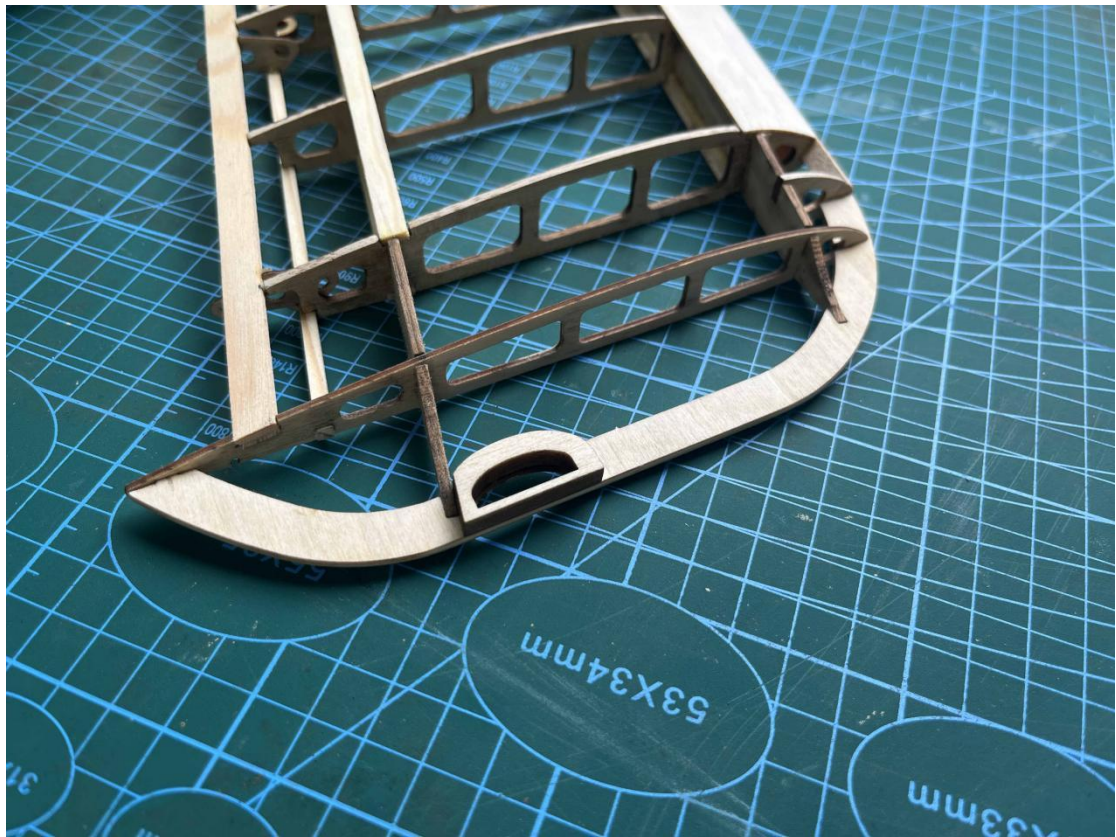

Step 41

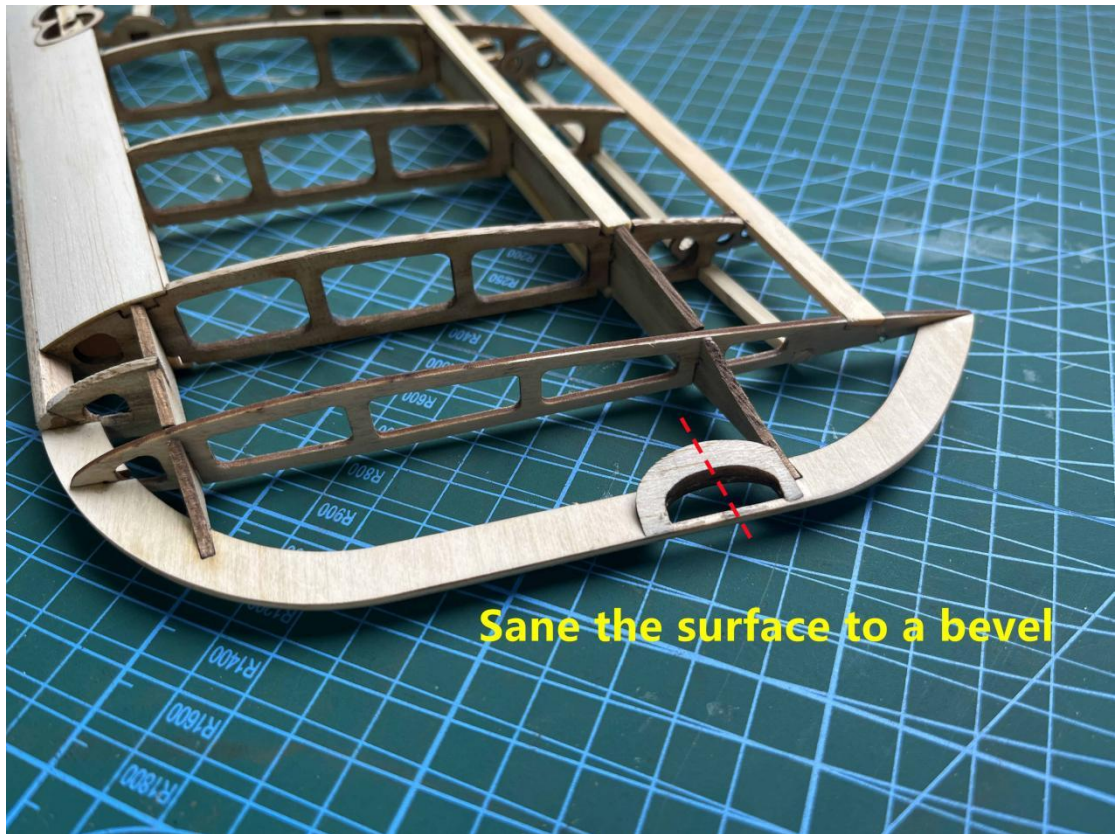

My Notes:

8.ASSEMBLY-Top Wings

Step 1

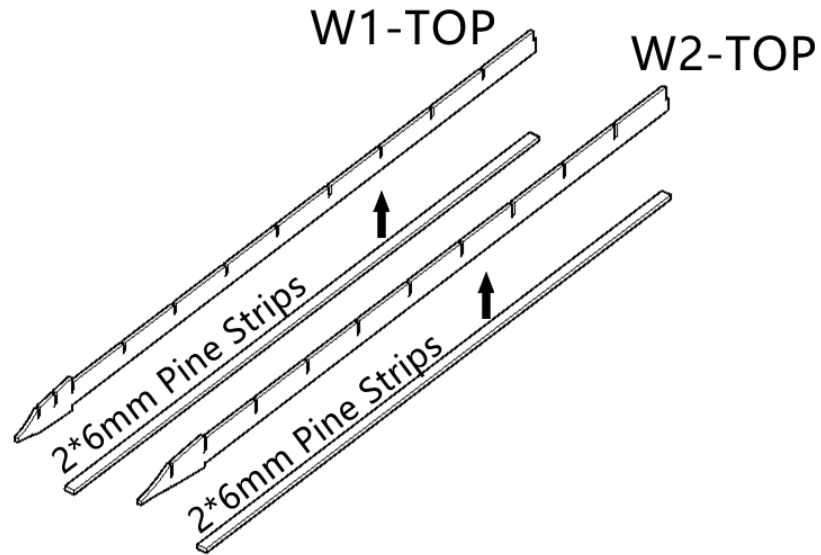

Step 2

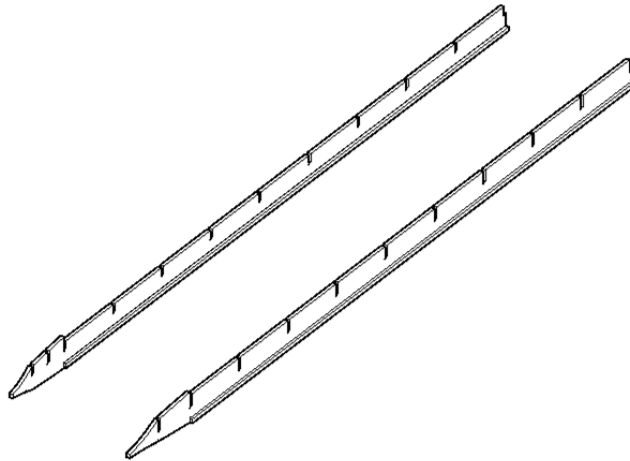

Step 3

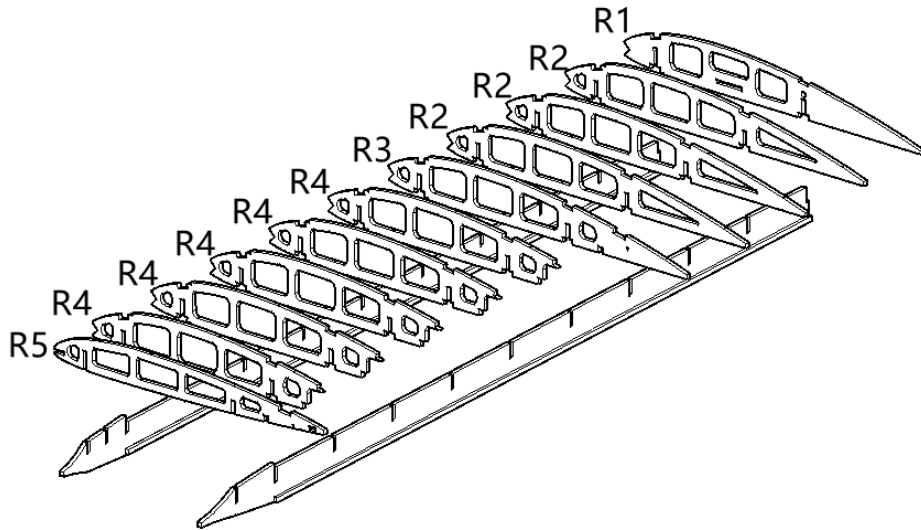

Step 4

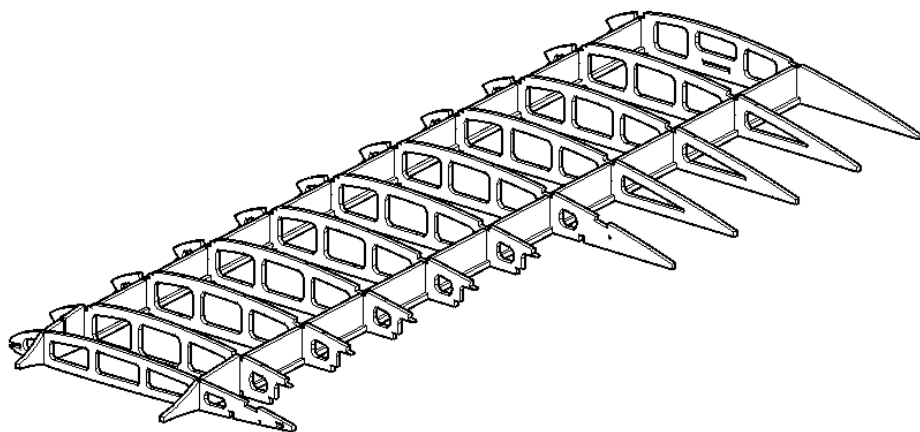

Step 5

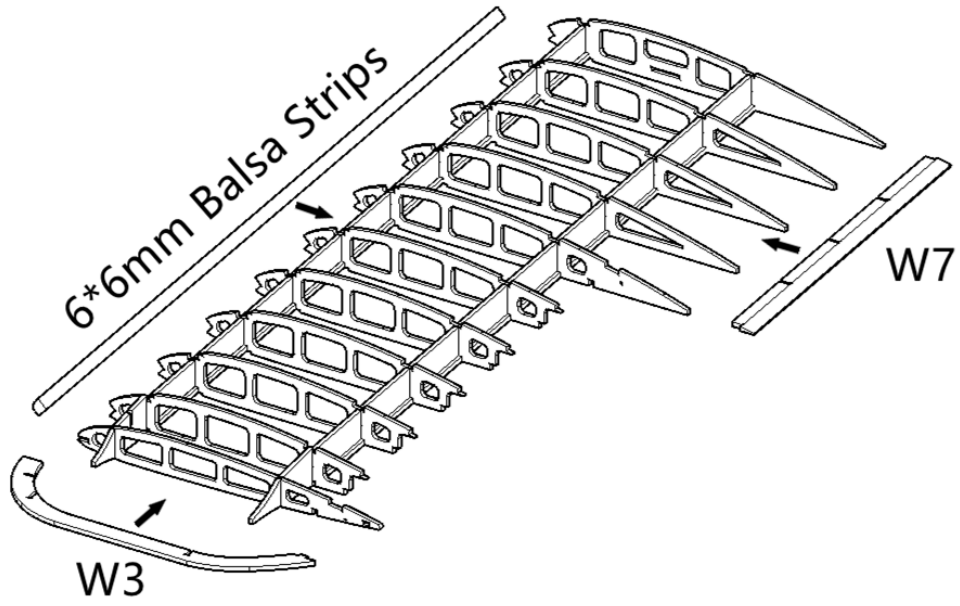

Step 6

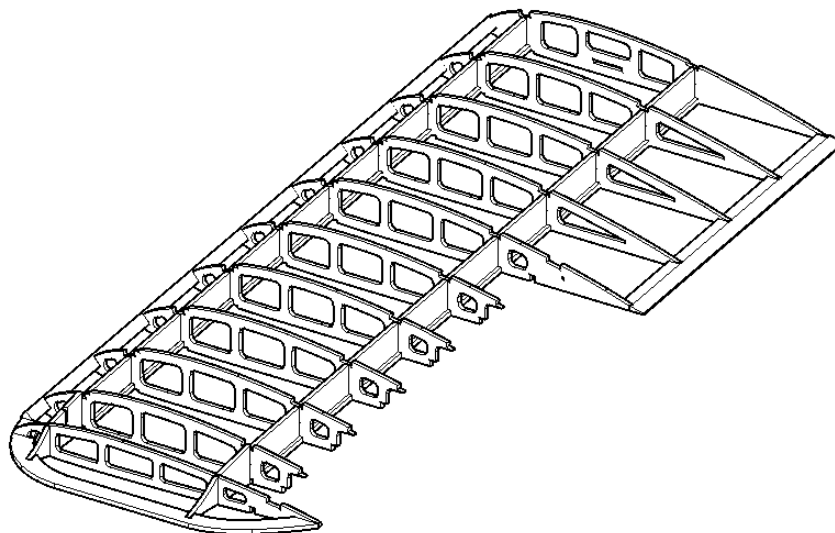

Step 7

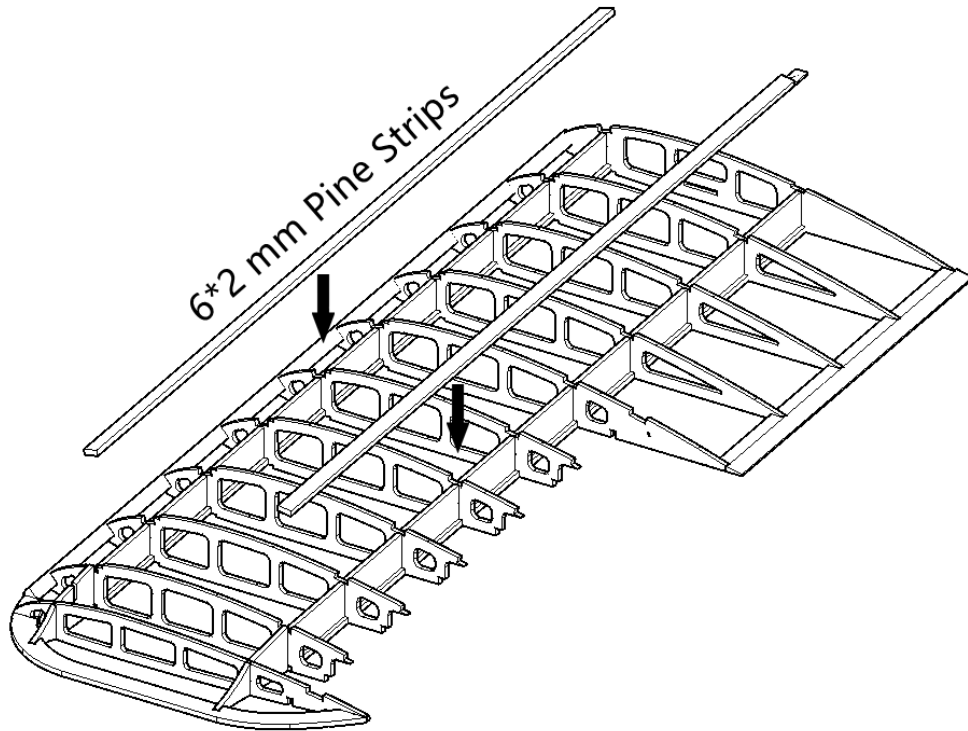

Step 8

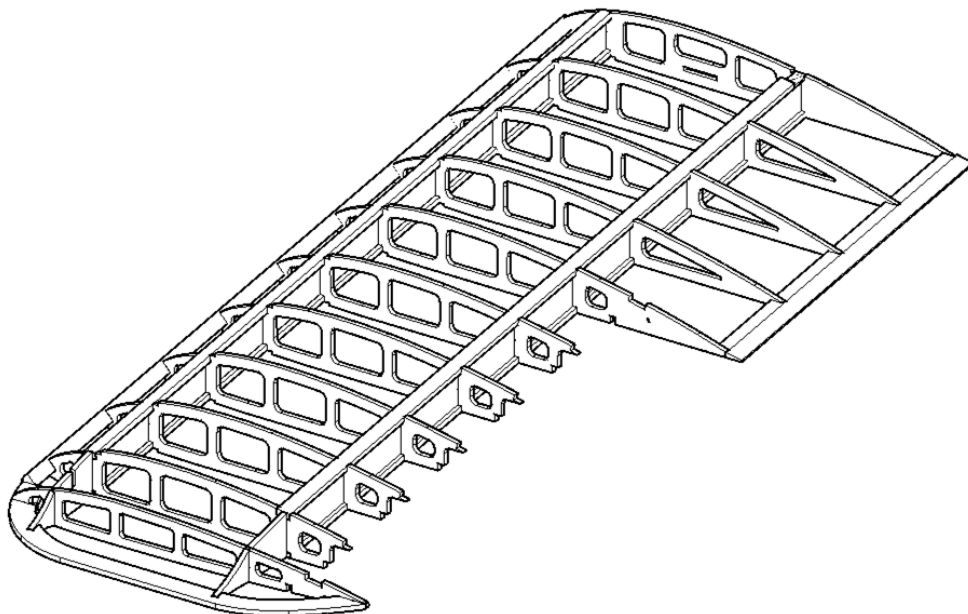

Step 9

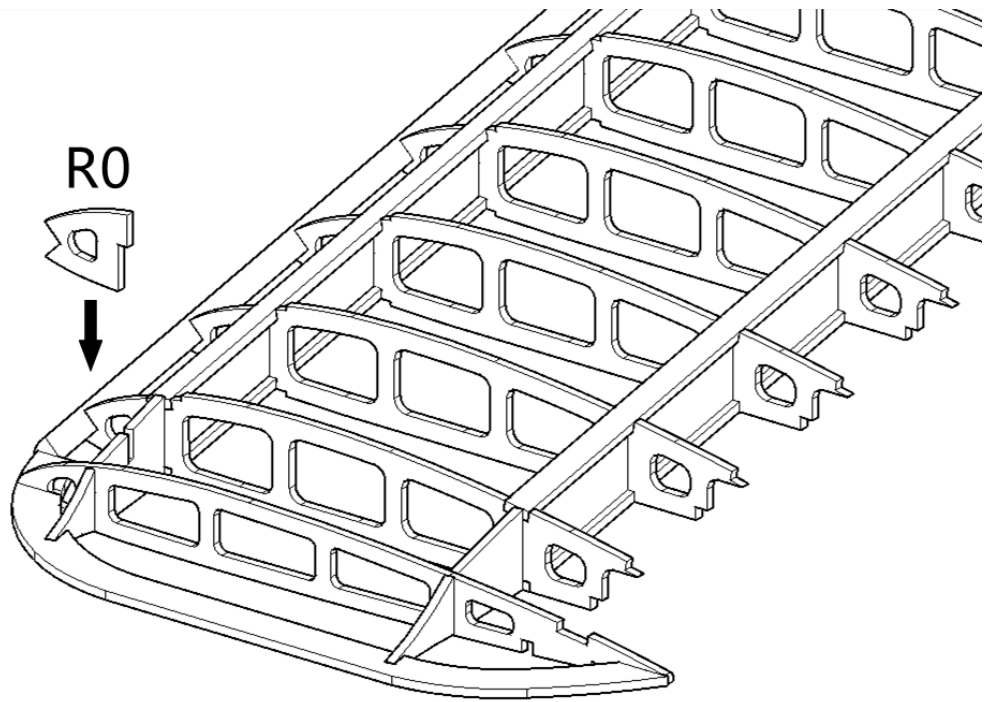

Step 10

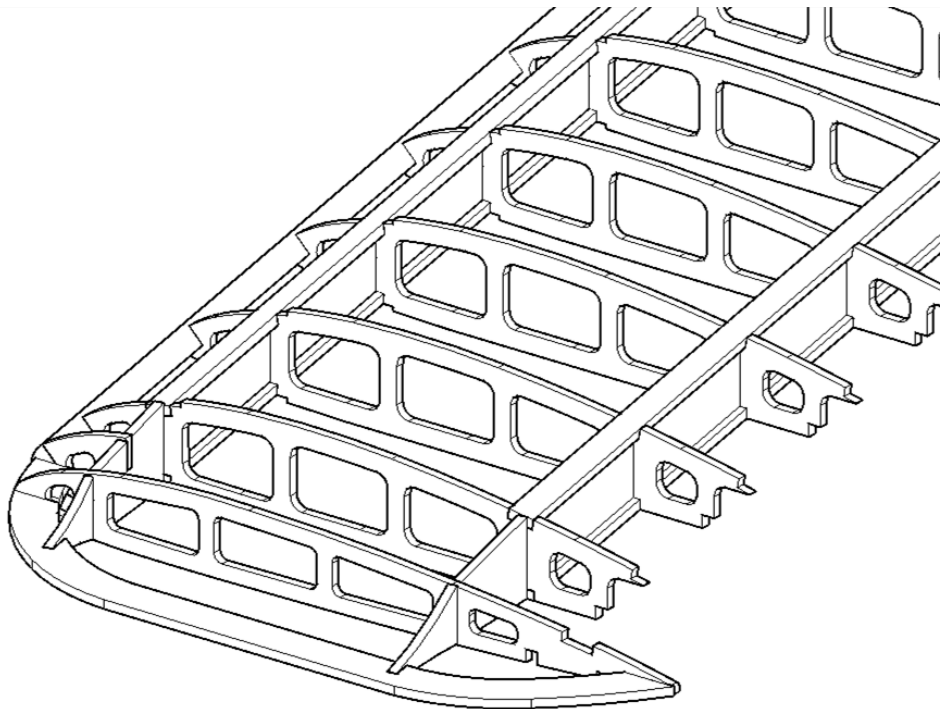

Step 11

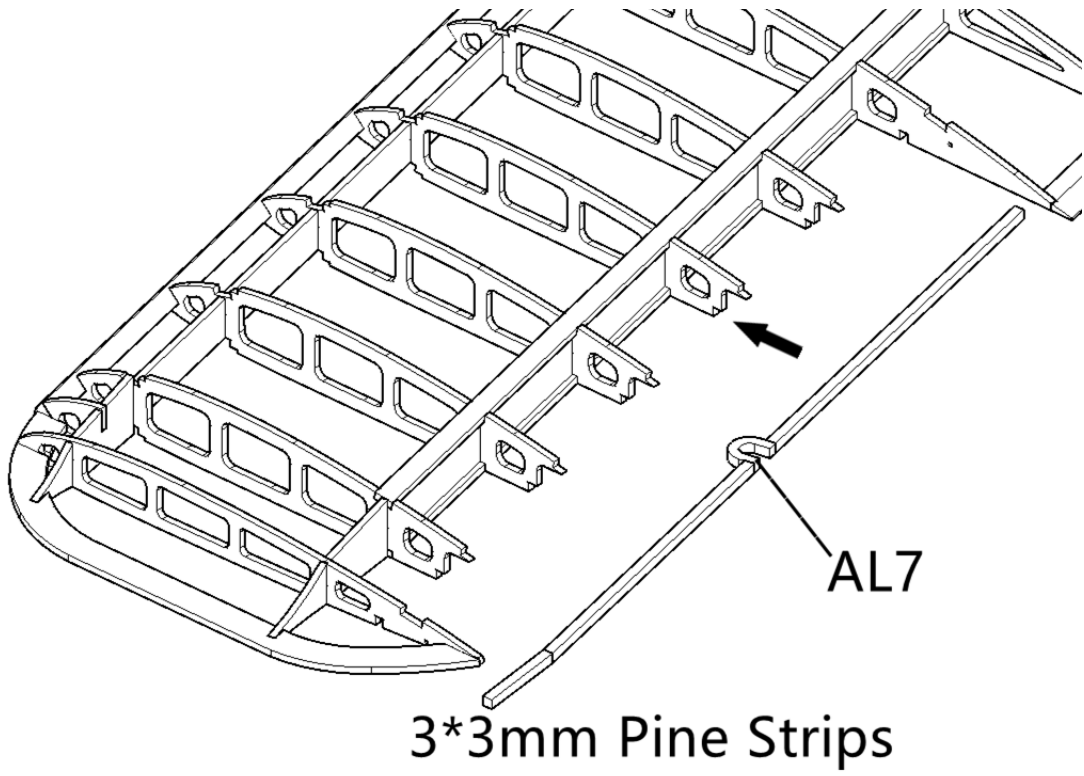

Step 12

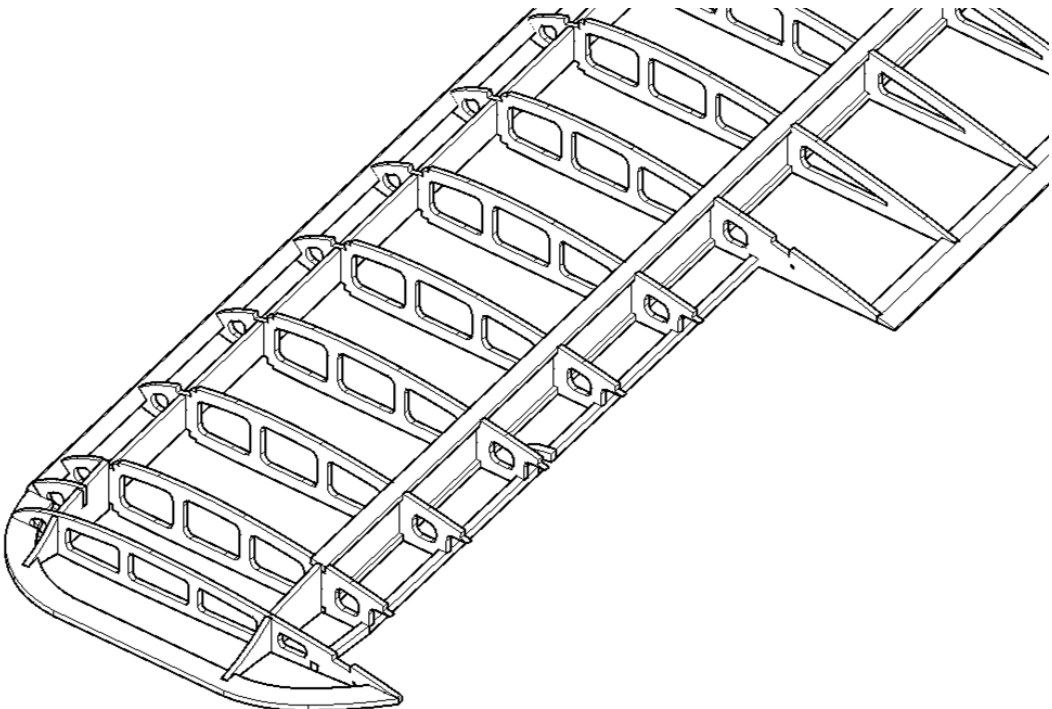

Step 13

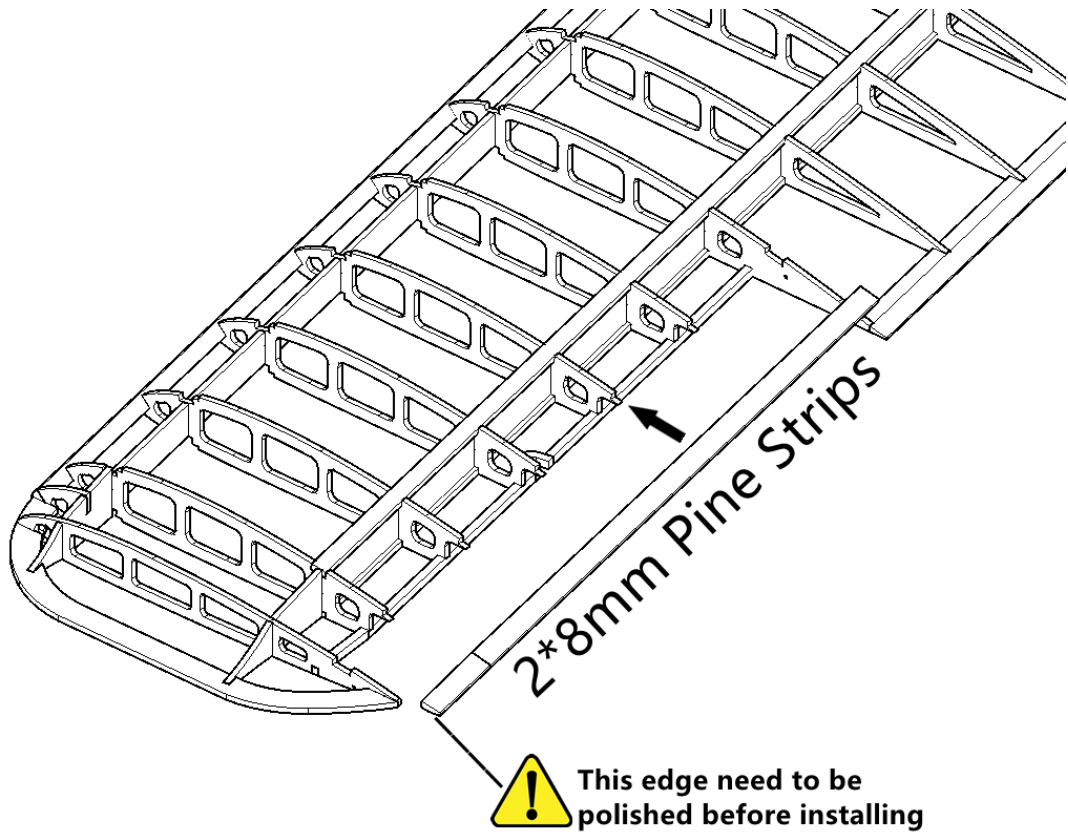

Step 14

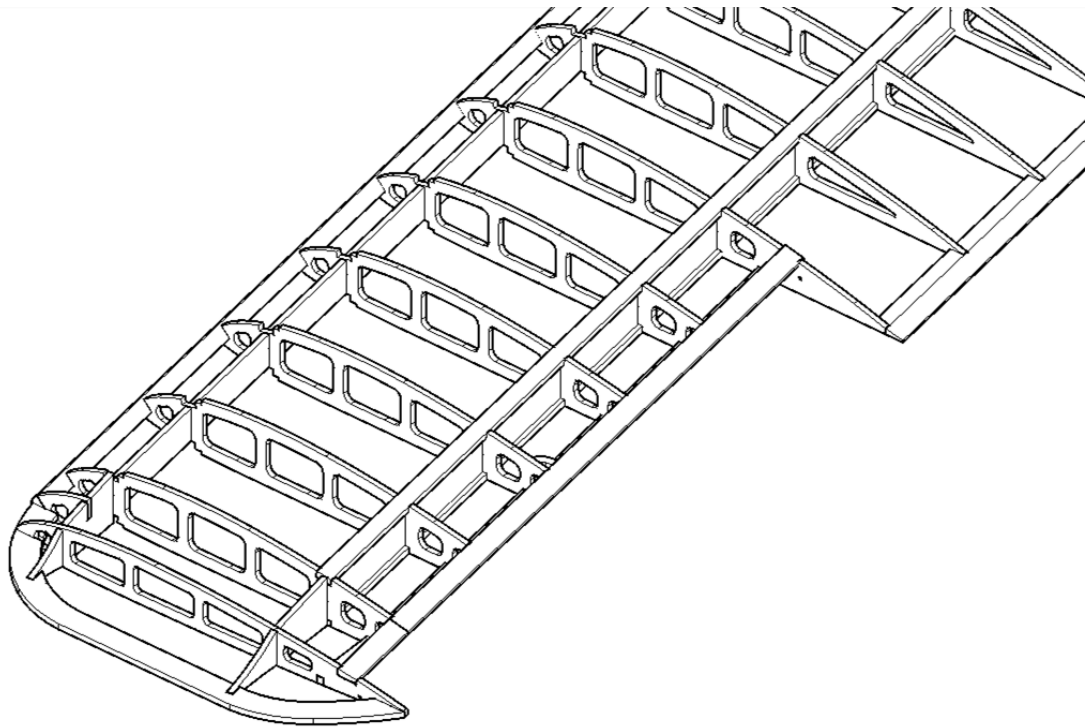

Step 15

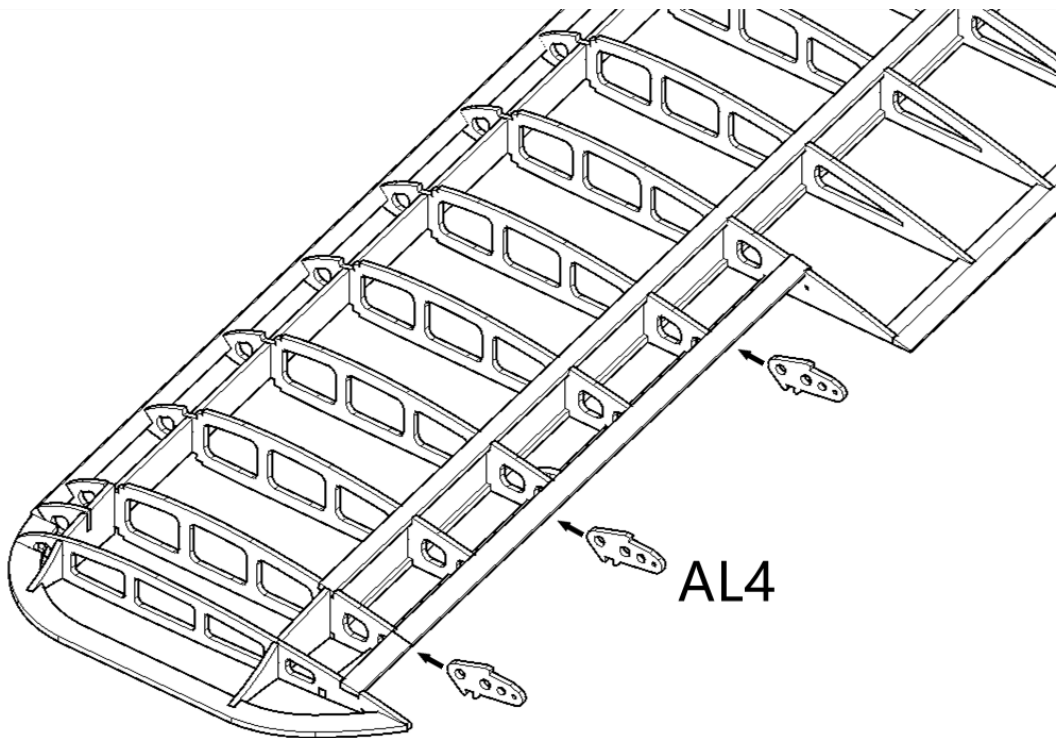

Step 16

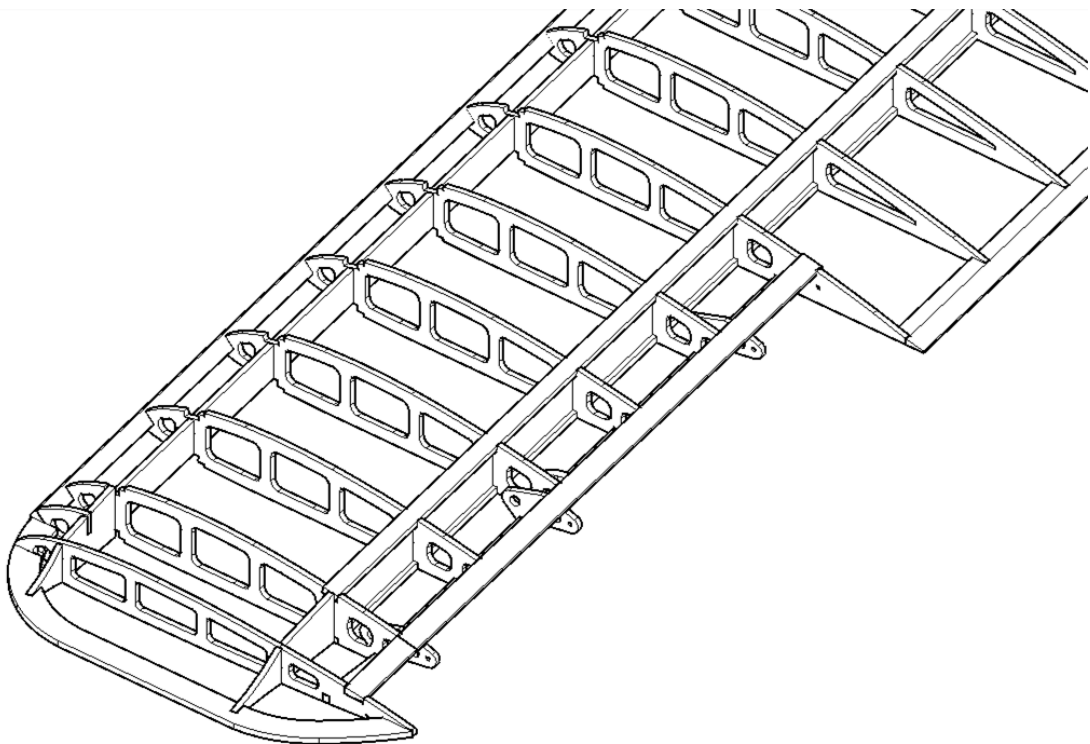

Step 17

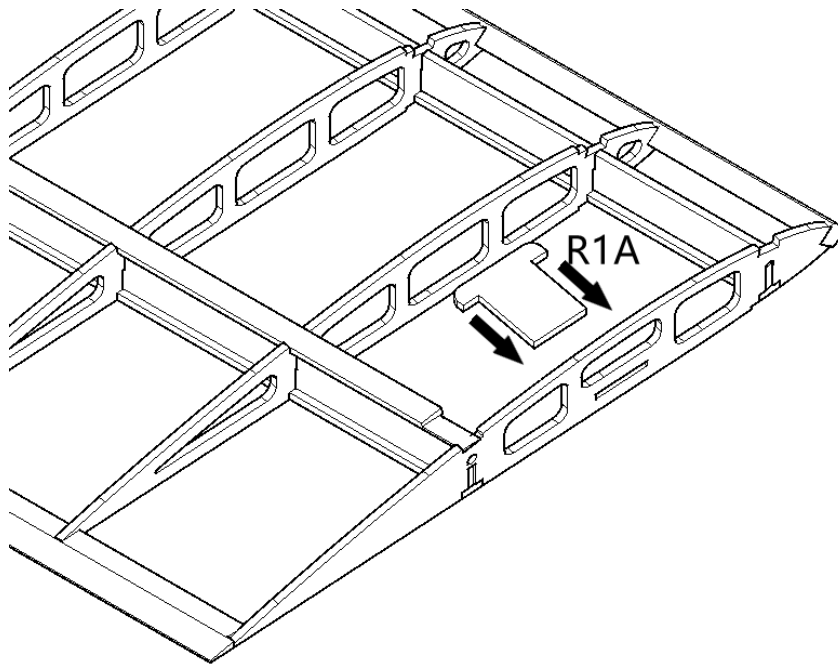

Step 18

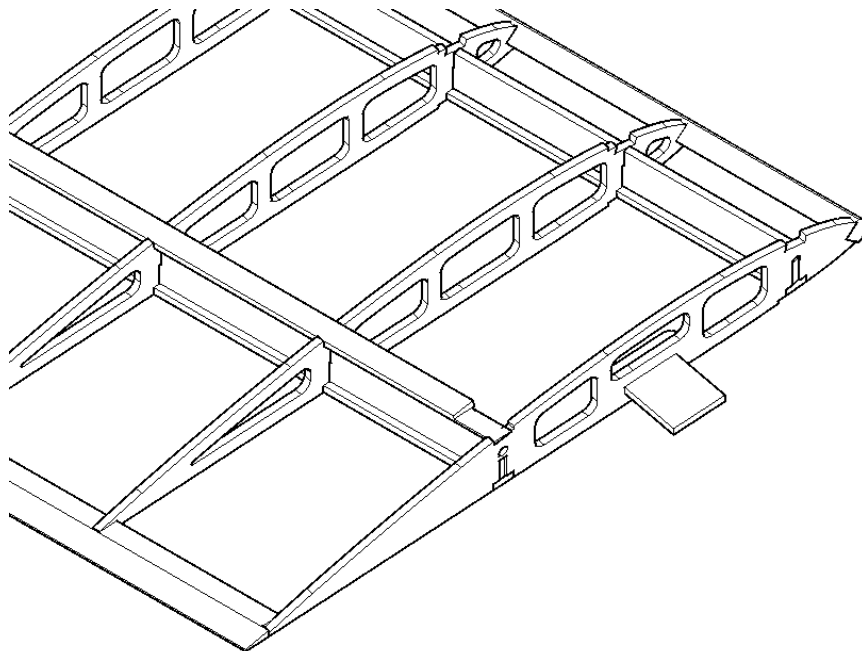

Step 19

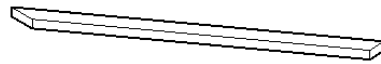
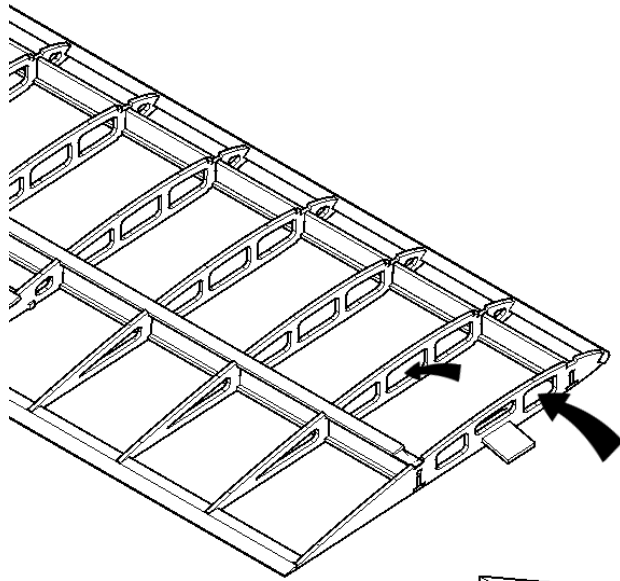

6*6mm Balsa Strips

Step 20

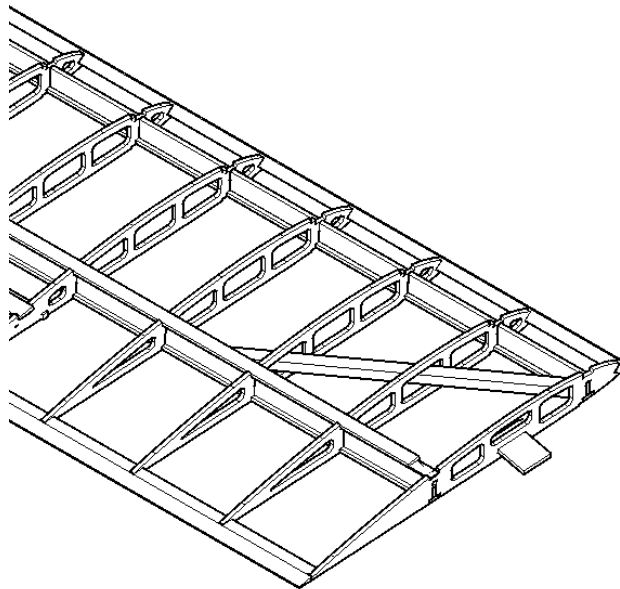

Step 21

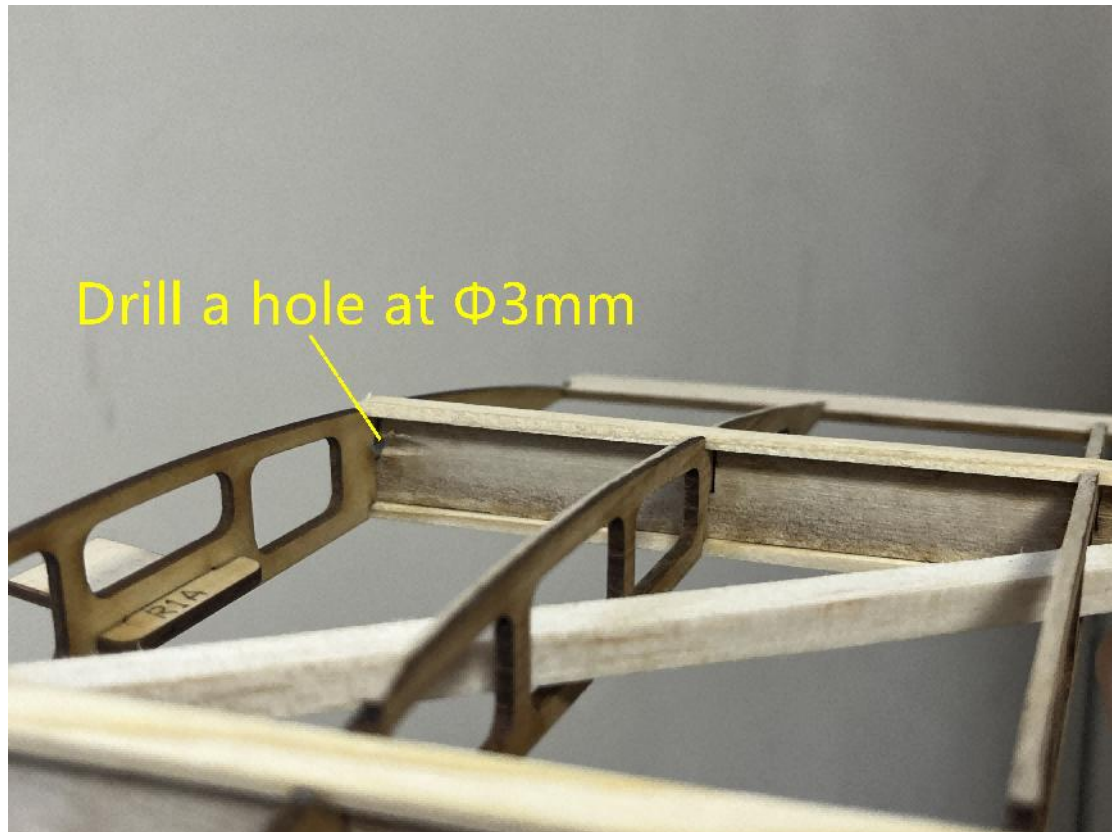

Step 22

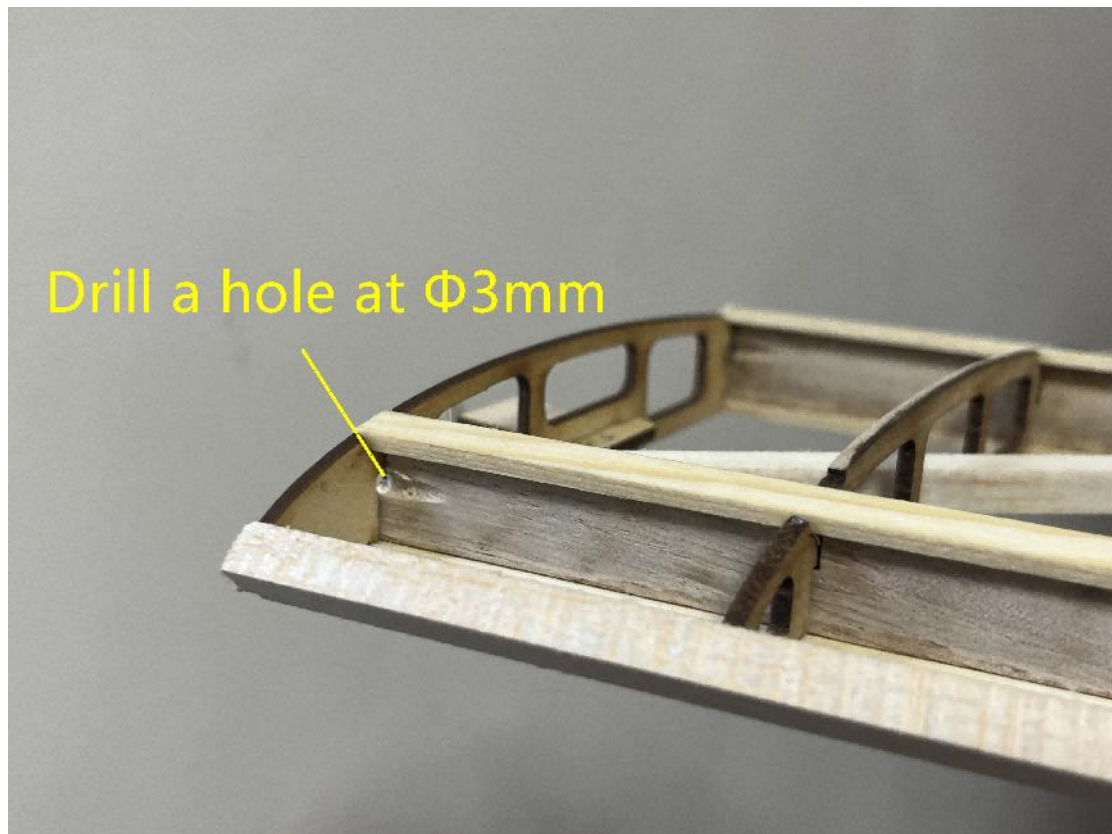

Step 23

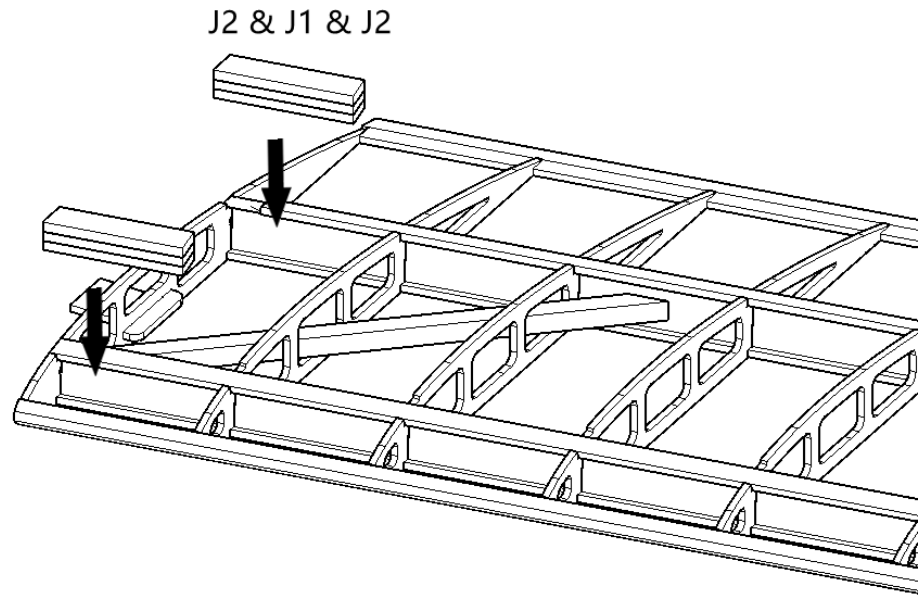

Step 24

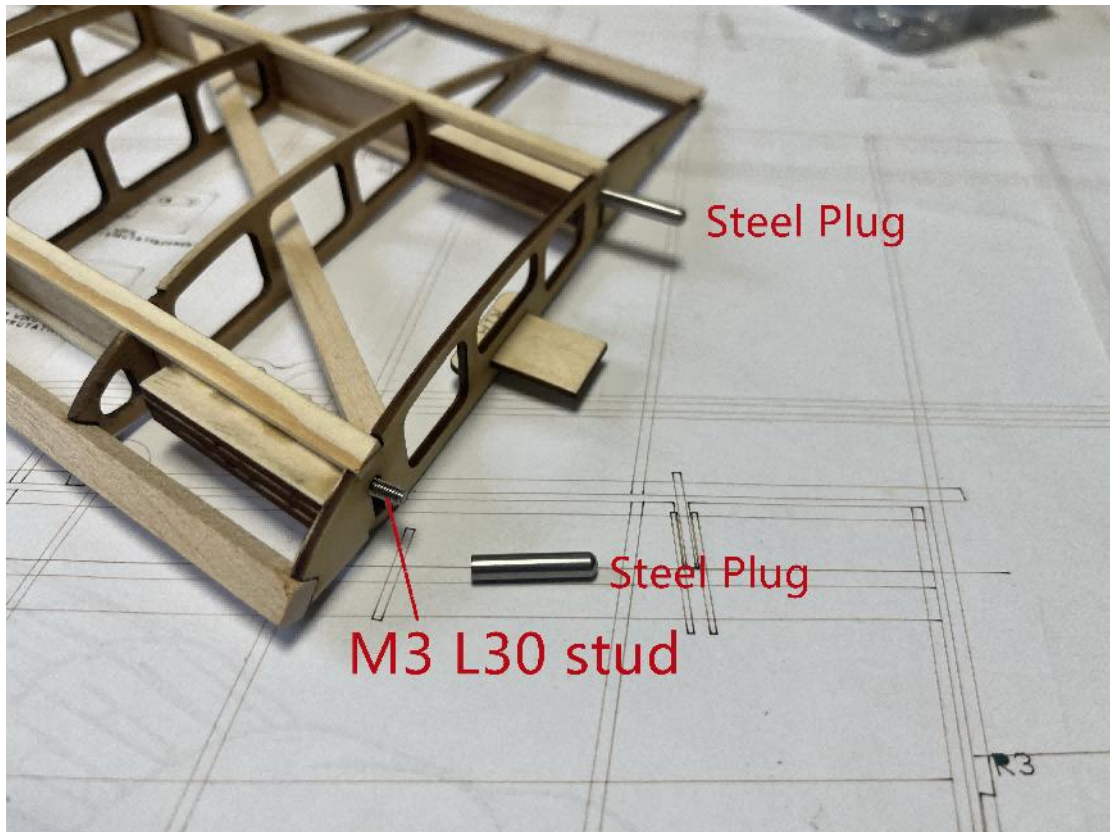

Step 25

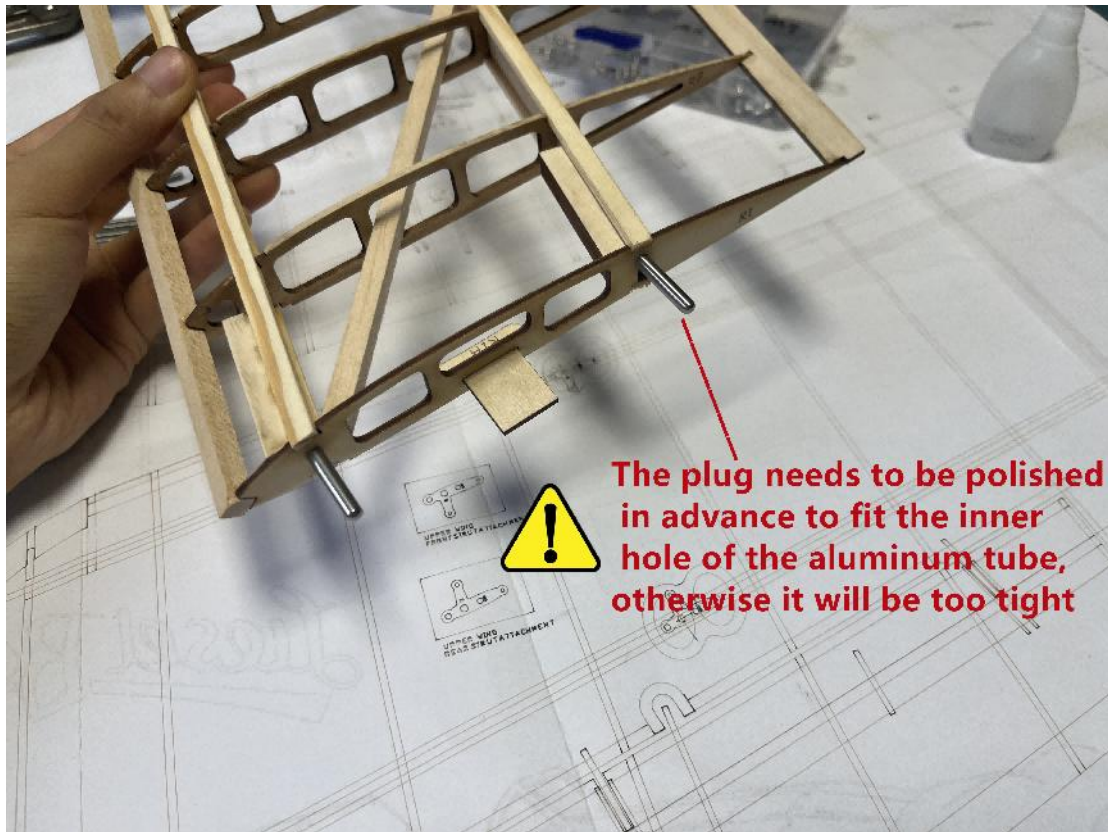

Step 26



Step 27

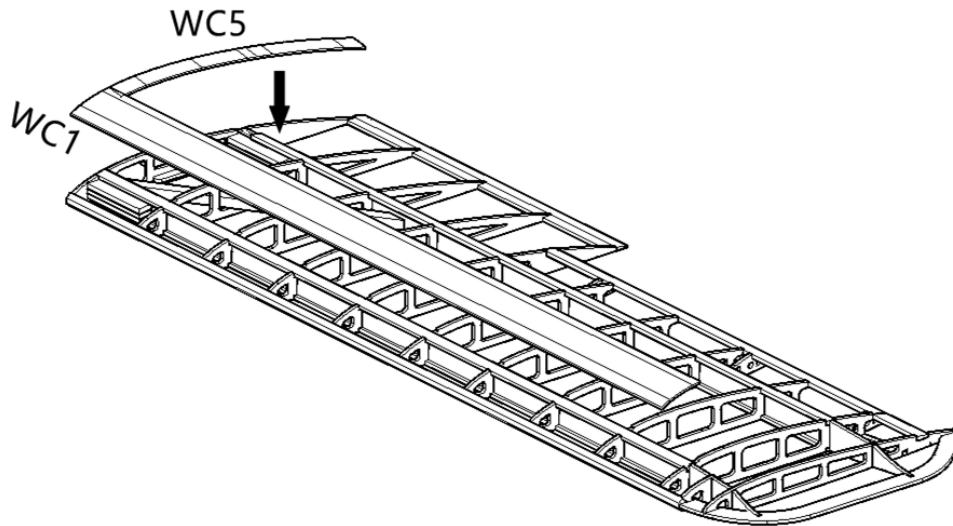

Step 28

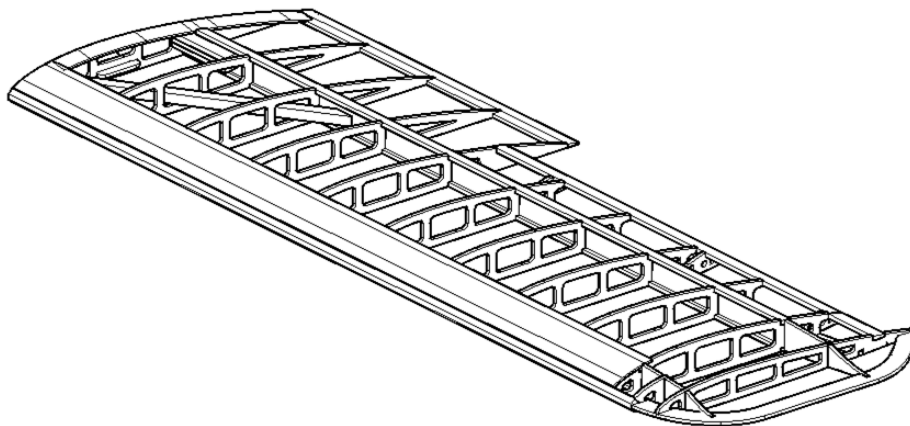

Step 29

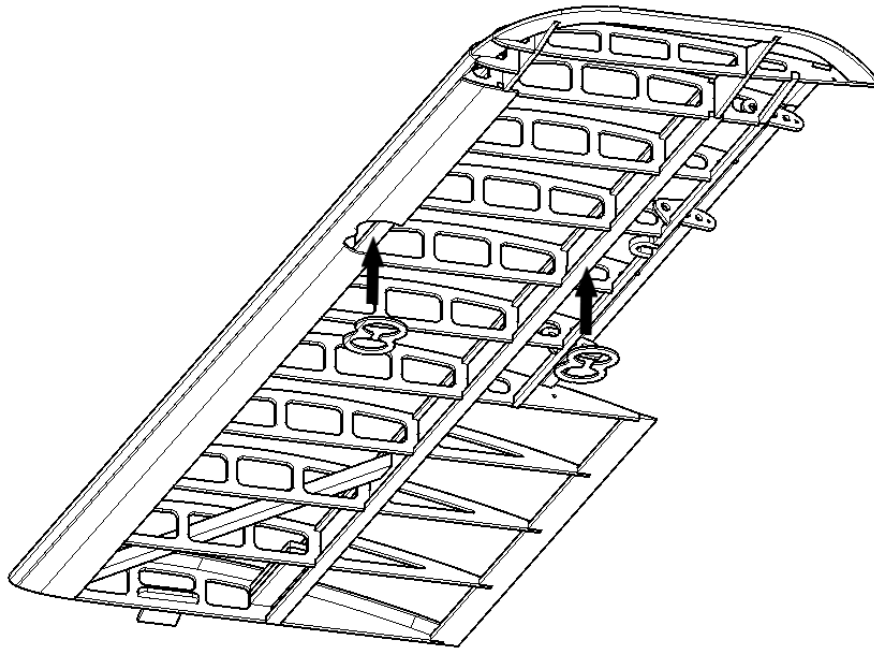

Step 30

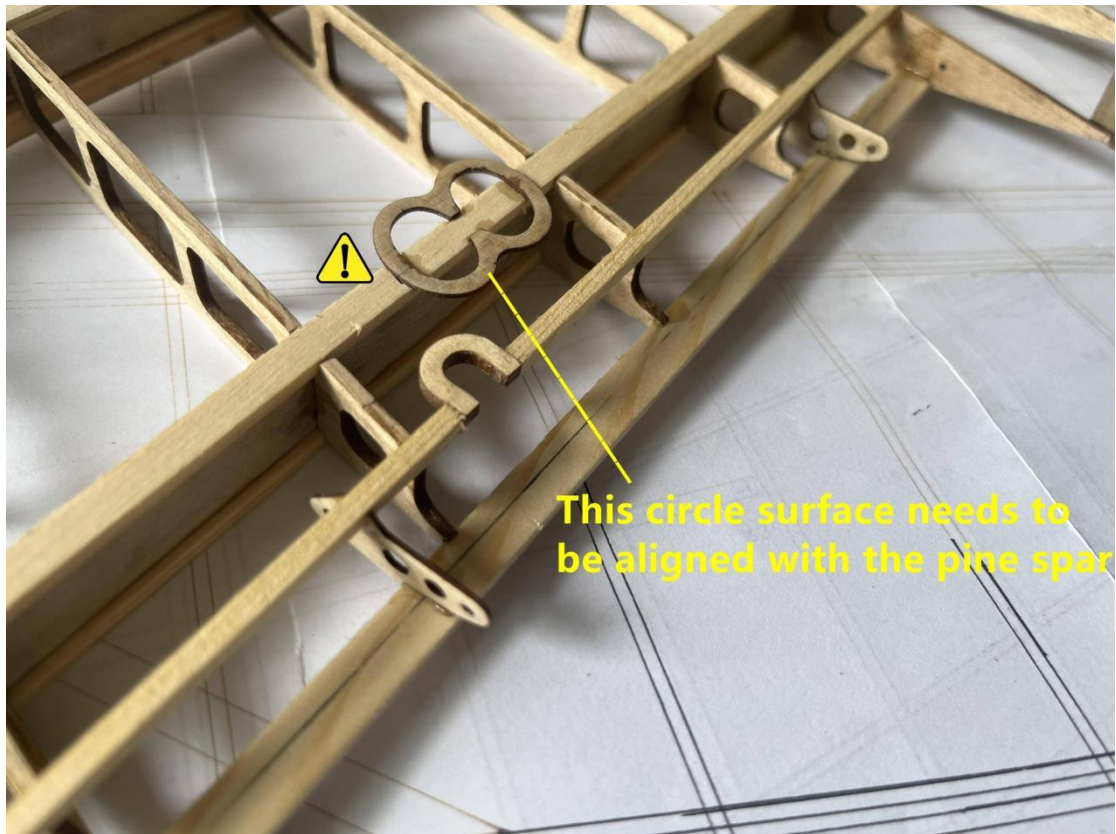

Step 31

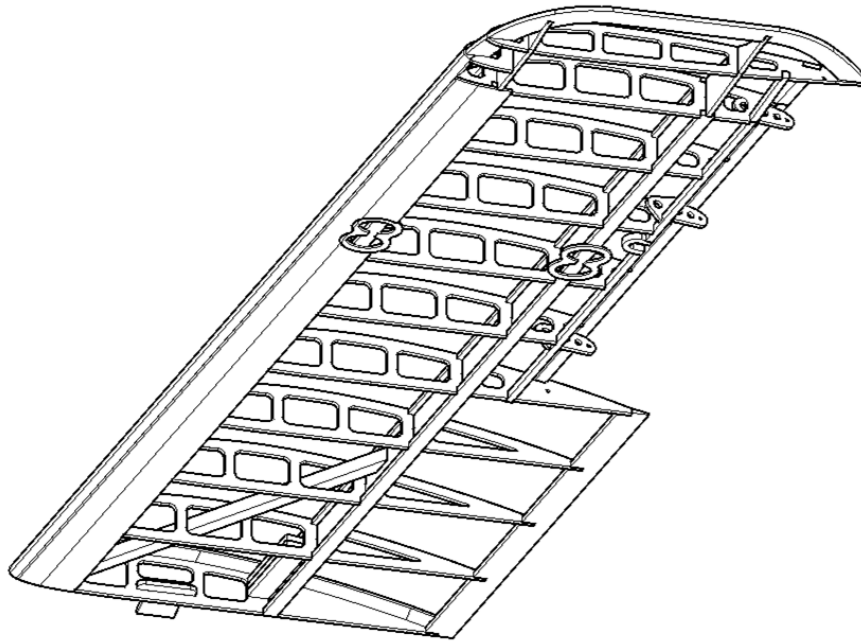

Step 32



Step 33

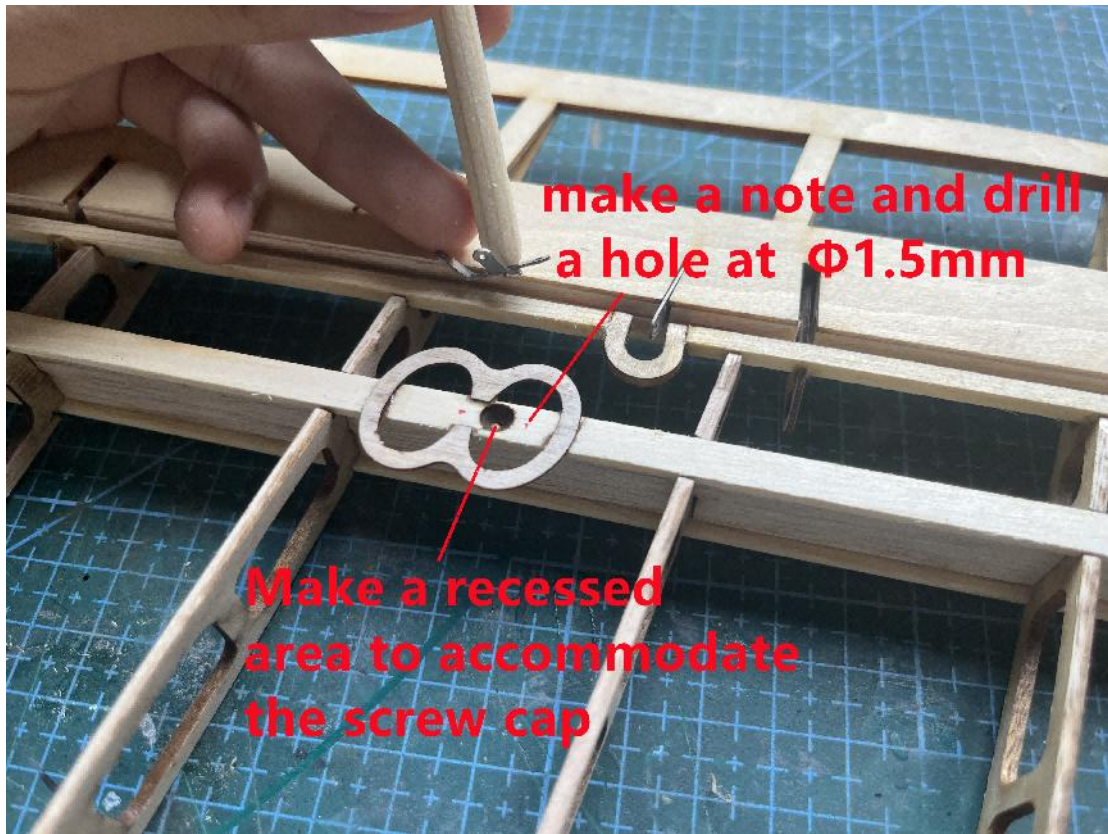

Step 34

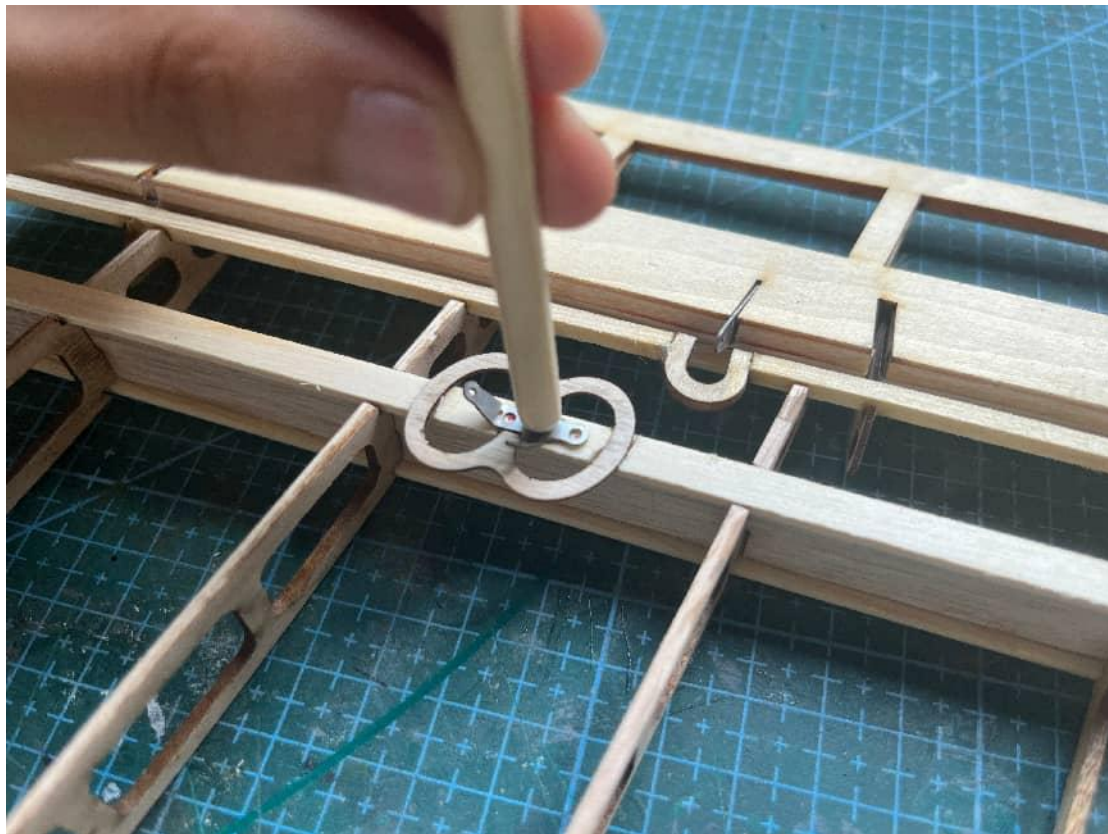

Step 35



Step 36



9.ASSEMBLY-Ailerons

Step 1

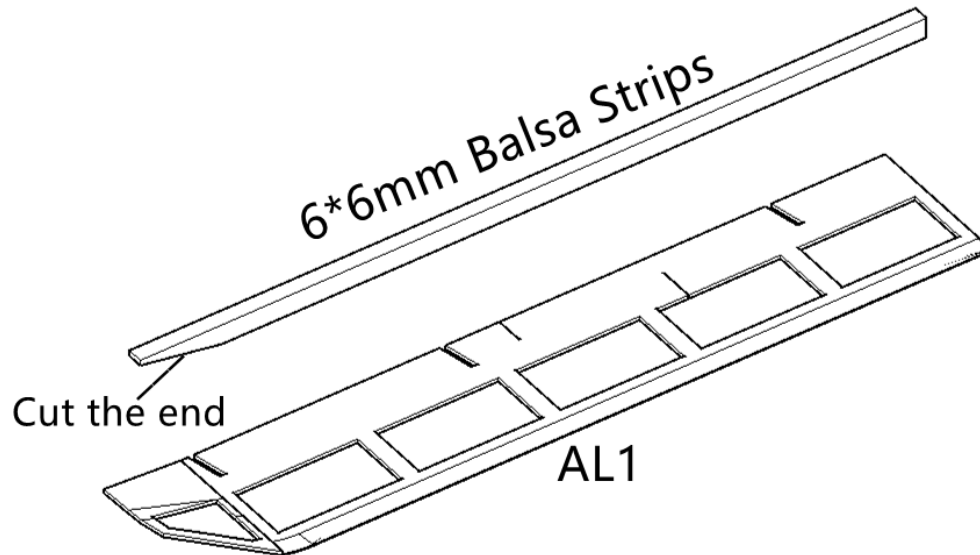

Step 2



Step 3

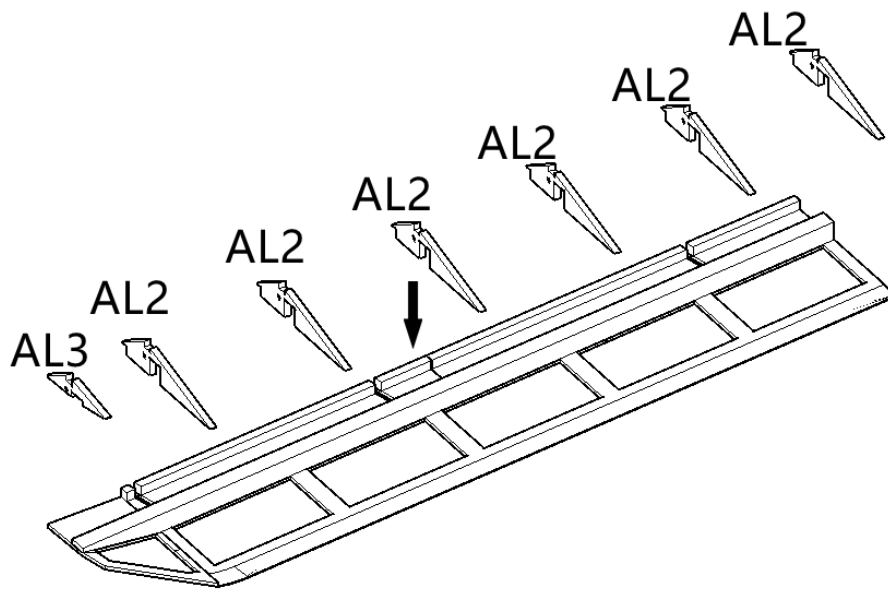

Step 4

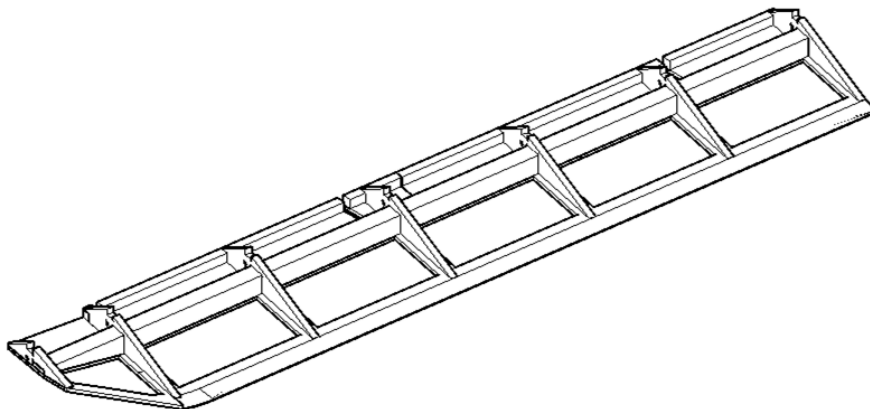

Step 5

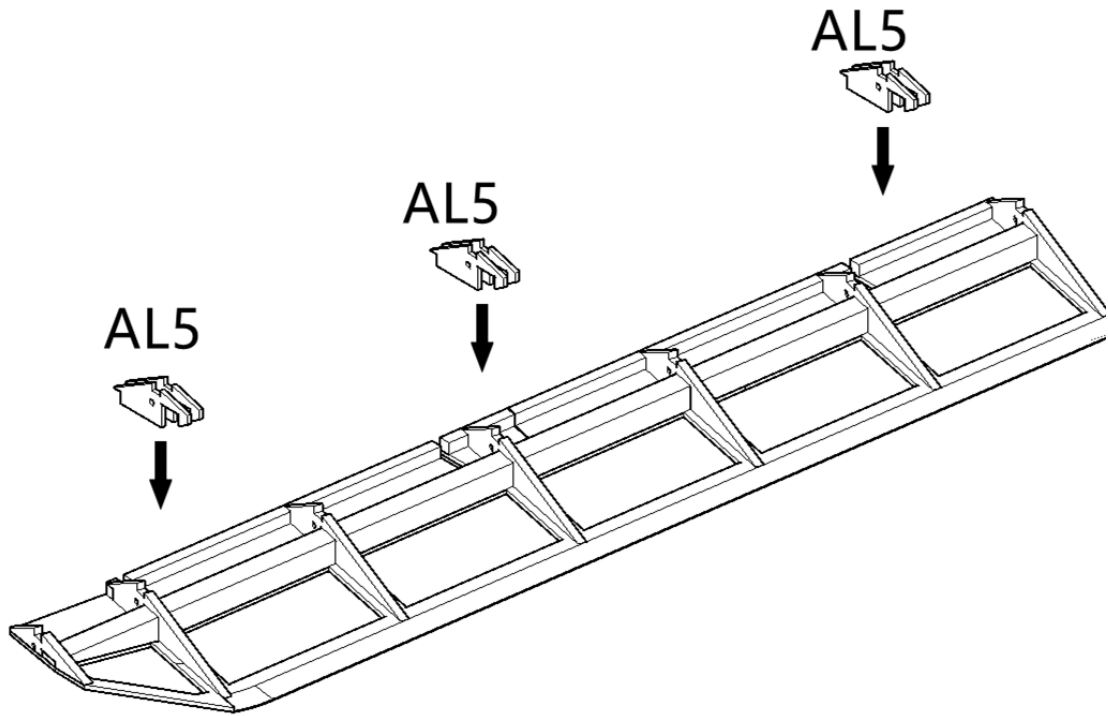

Step 6

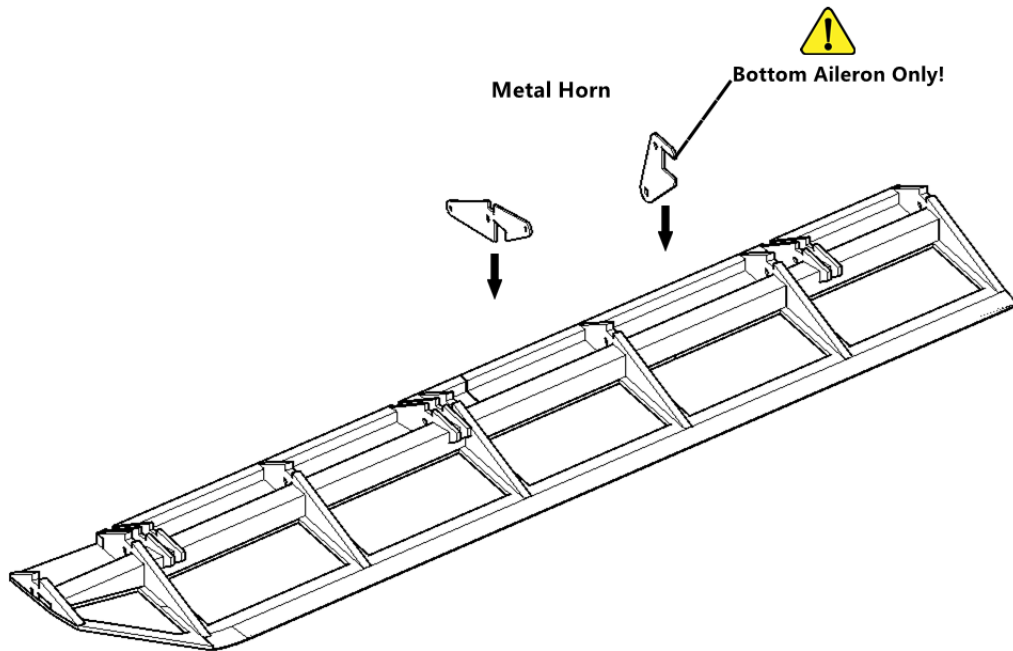

Step 7

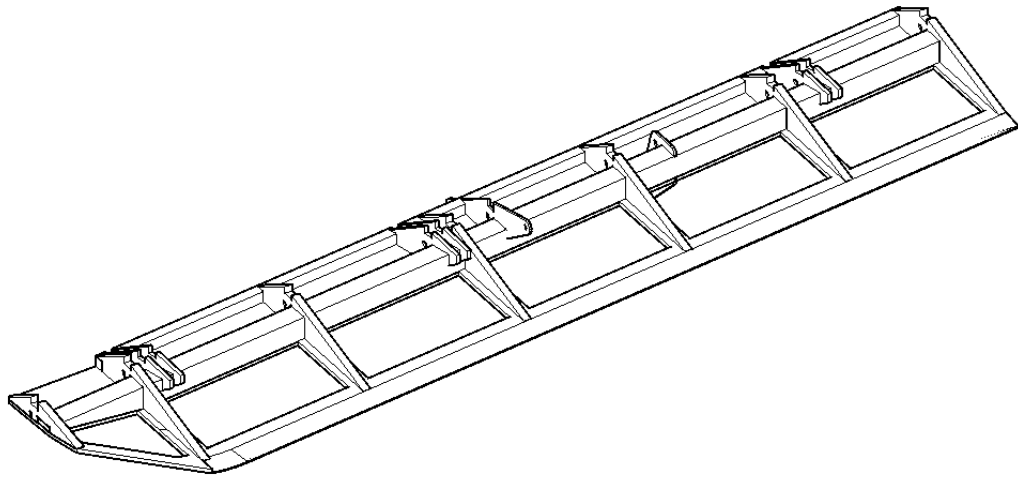

Step 8

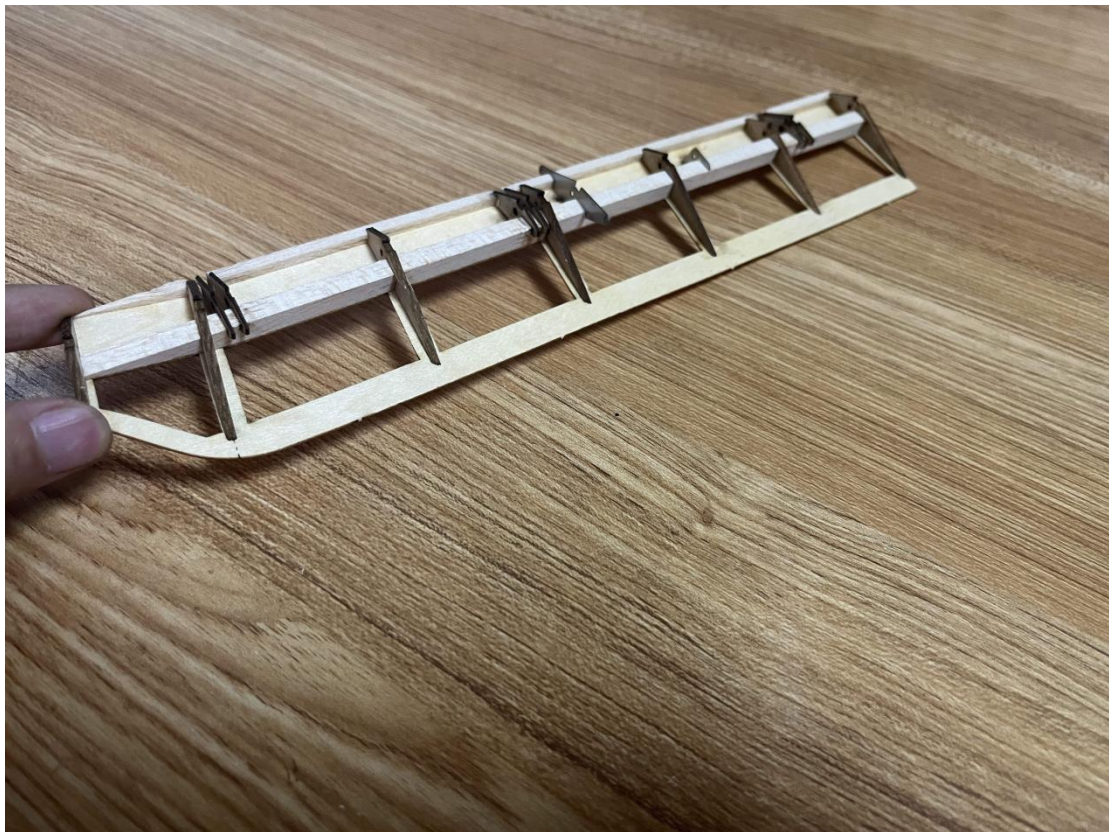

Step 9

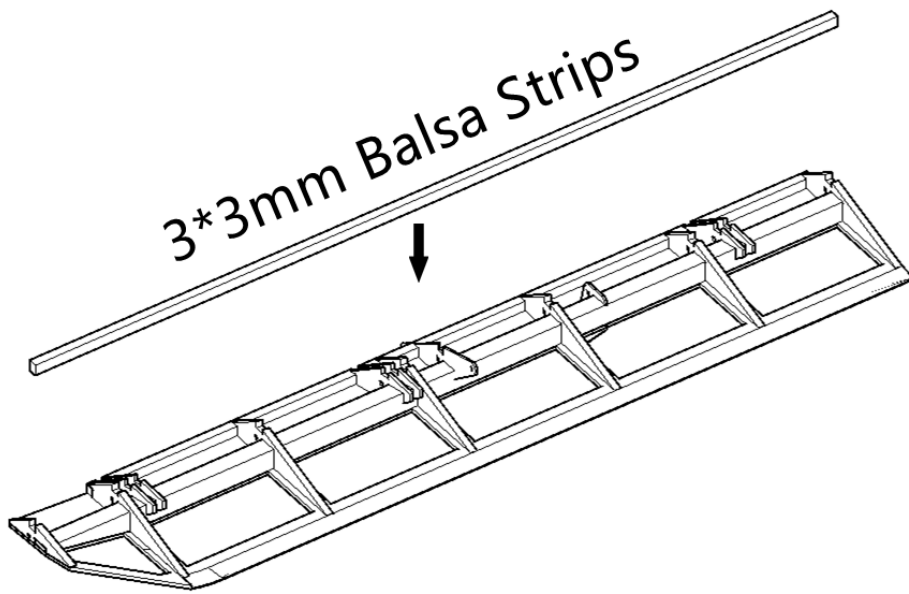

Step 10

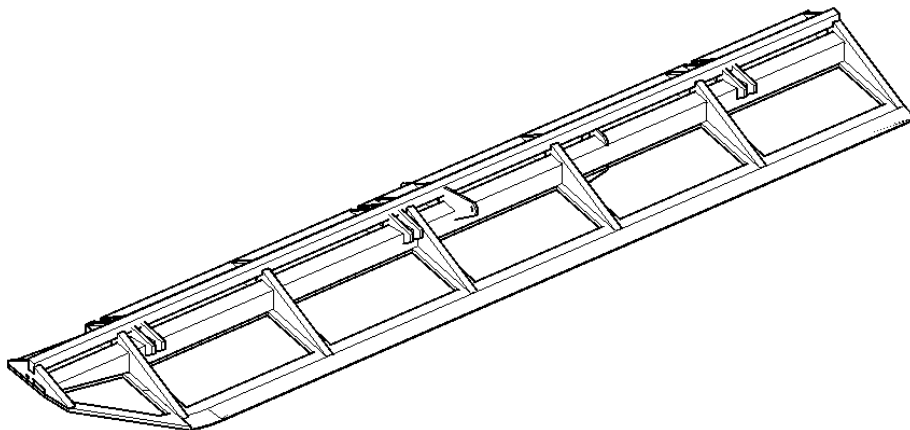

Step 11



Step 12

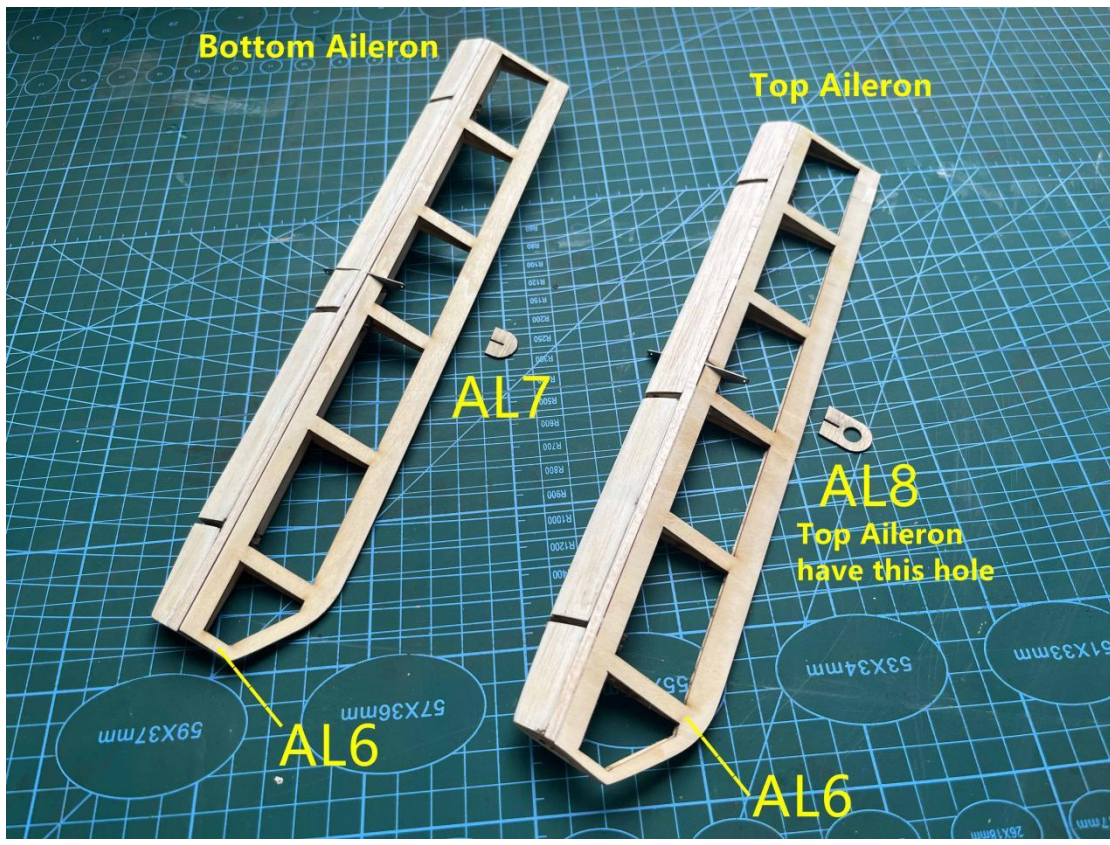

Step 13

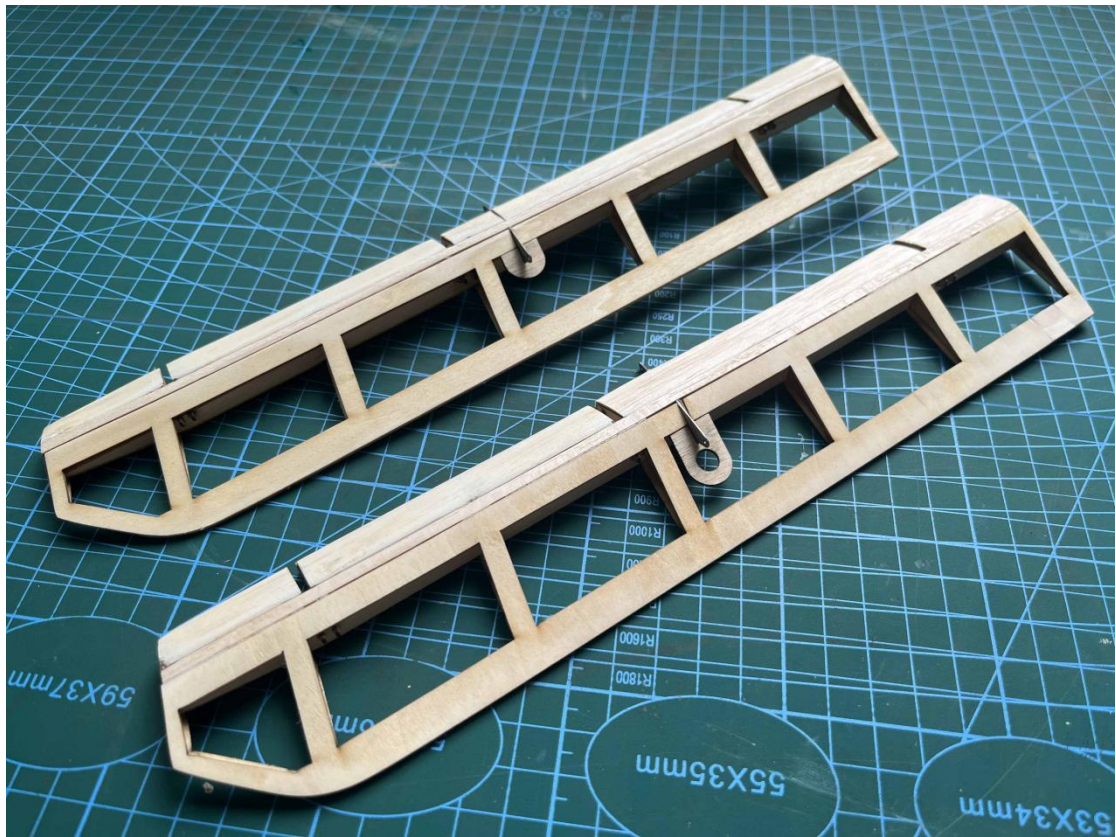

My Notes:

10. Electronics (just an Example)

Step 1

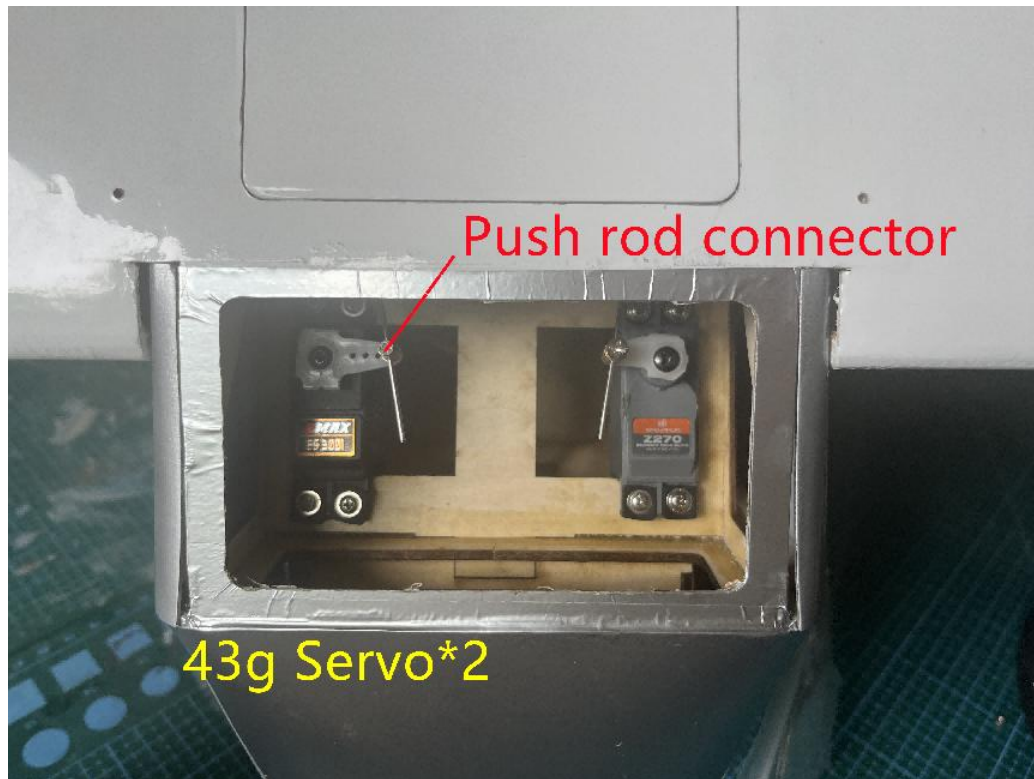

Step 2



Step 3



Step 4



Step 5

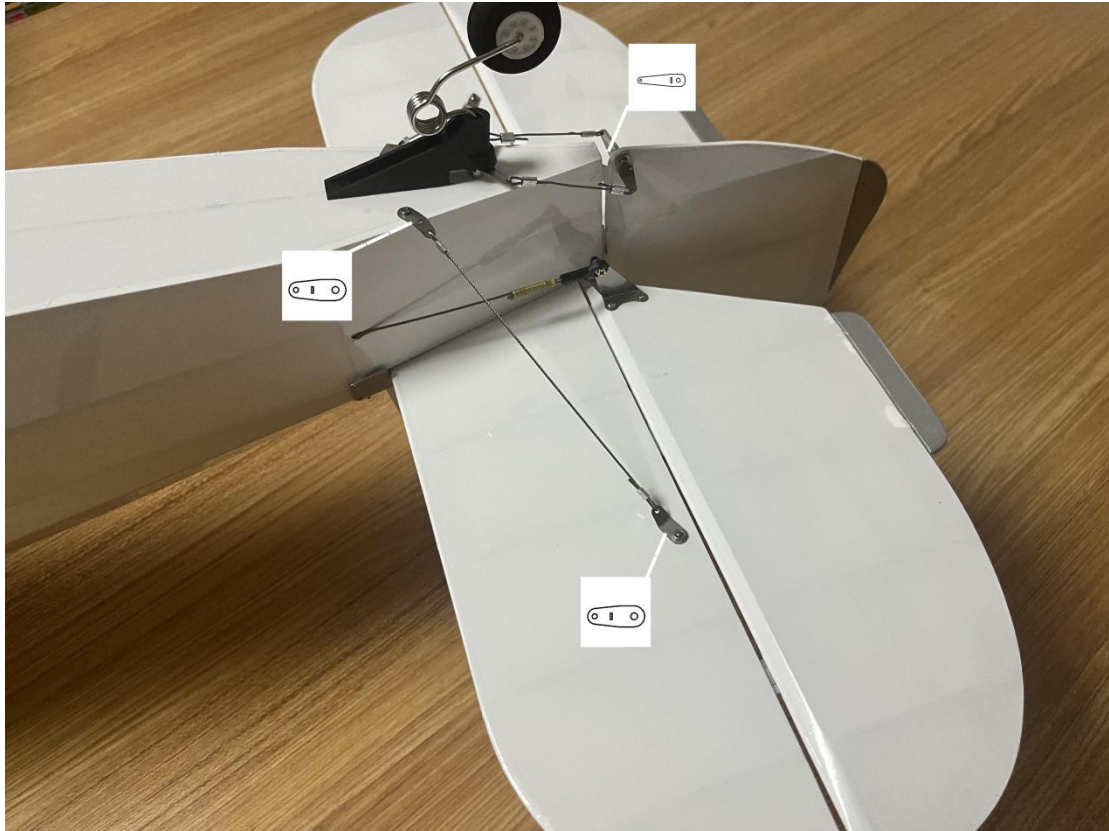

Step 6

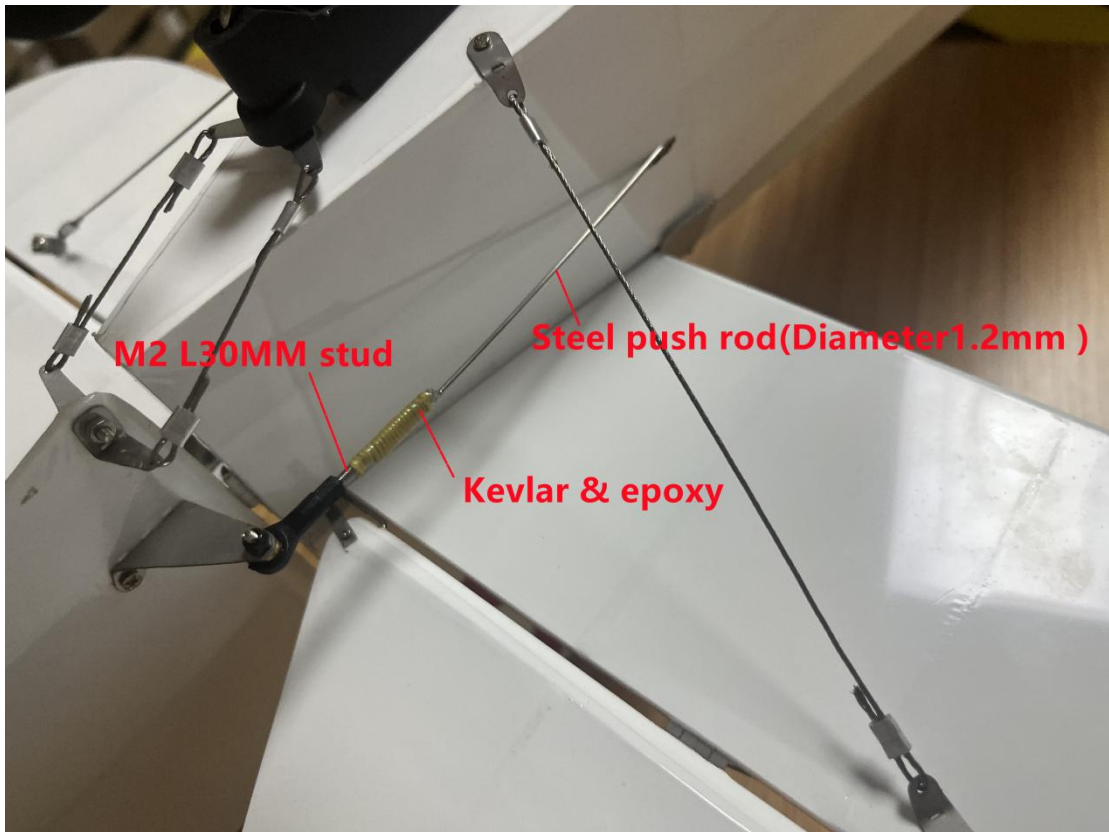

Step 7



Step 8

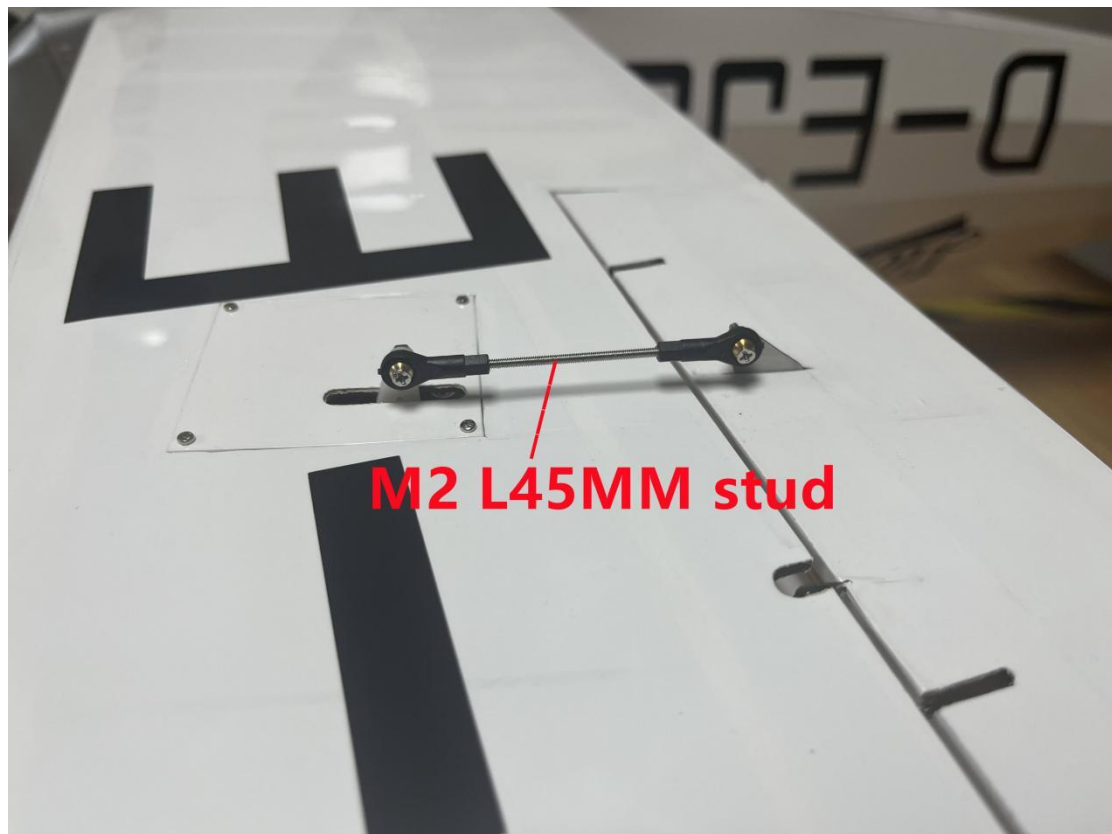

Step 9



Step 10

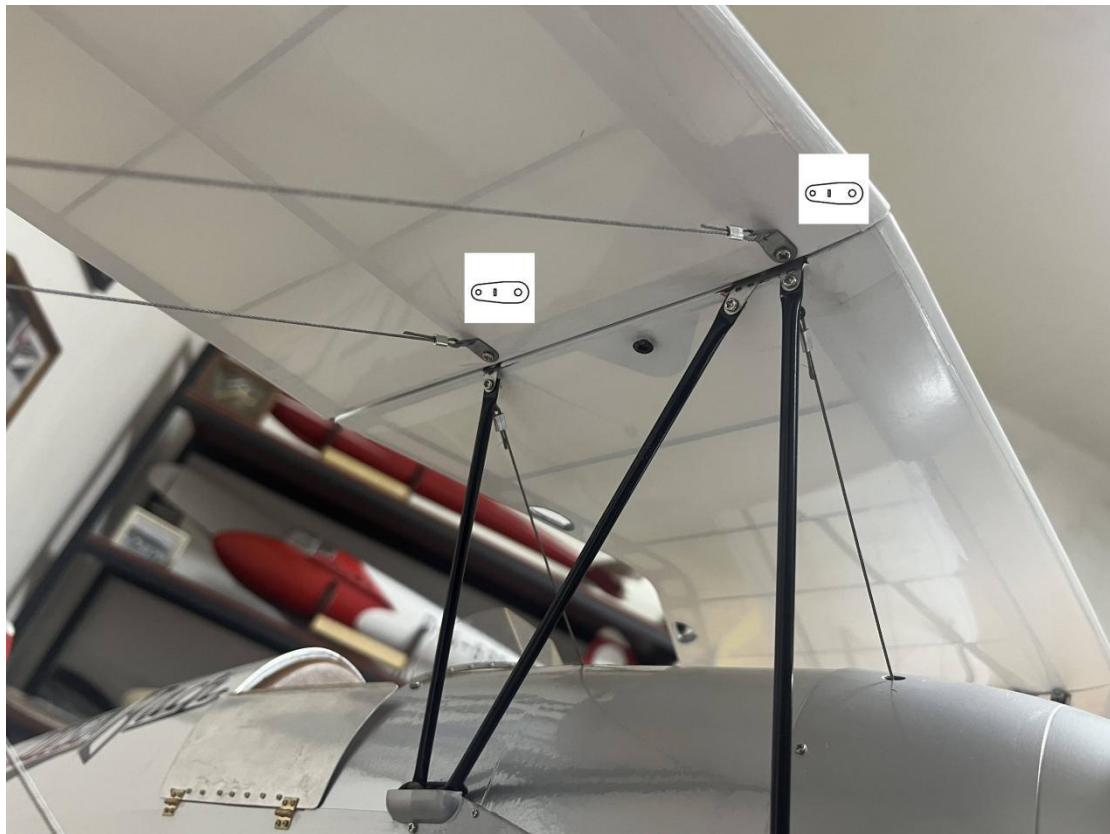

Step 11



How to remove the wings: Step 1 – Remove the upper wing

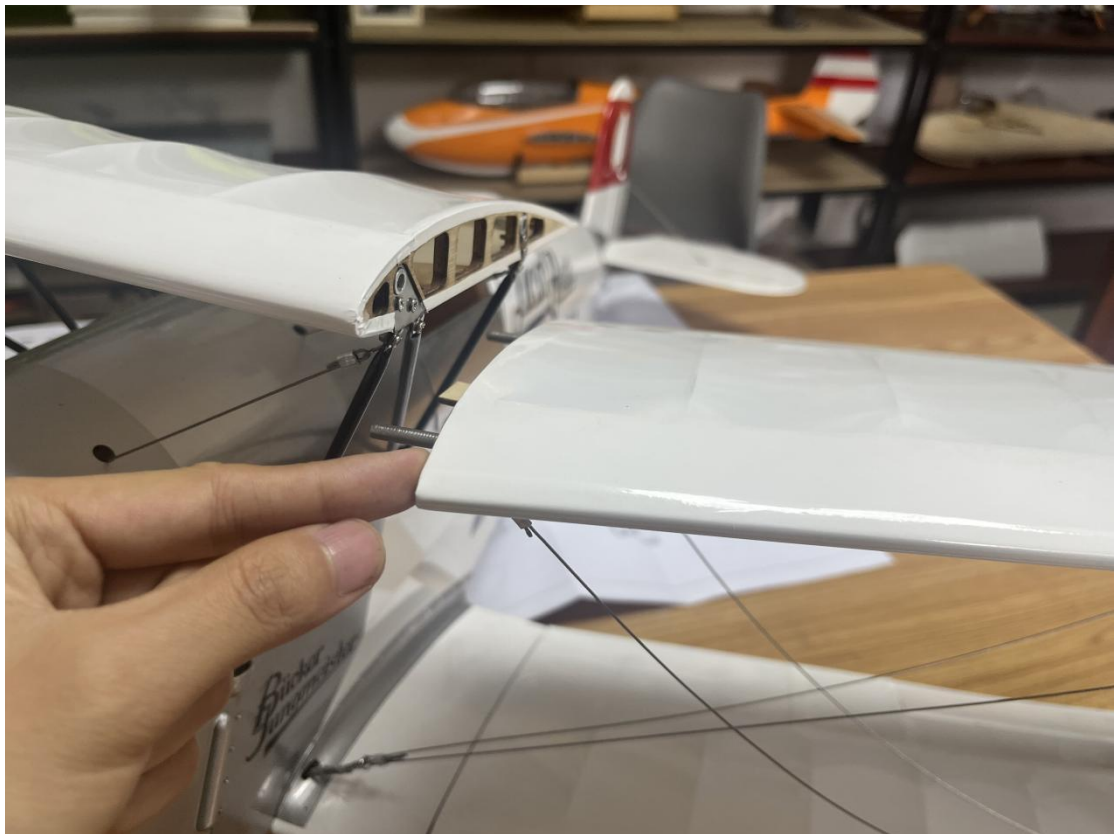

How to remove the wings: Step 2 – Remove these two wires from metal buckle

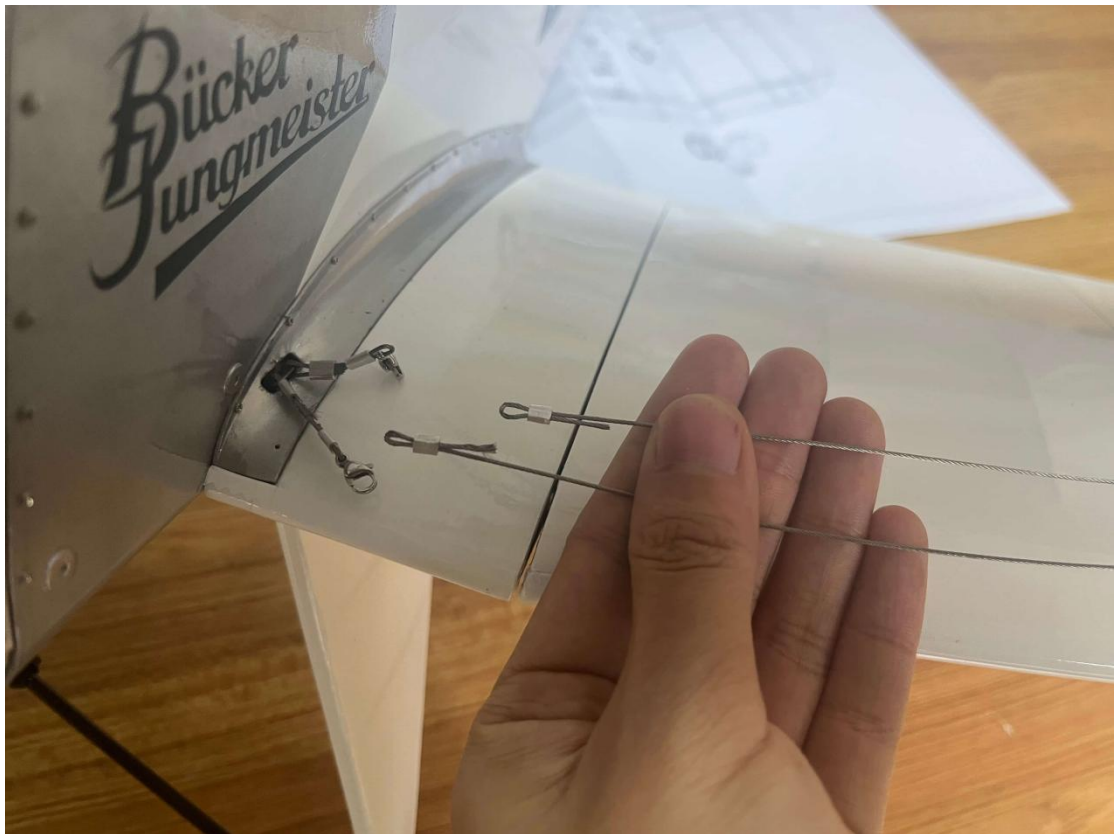

How to remove the wings: Step 3 – Remove bottom wing





BEFORE YOU FLY

1. CG: 110mm from upper wing Leading edge

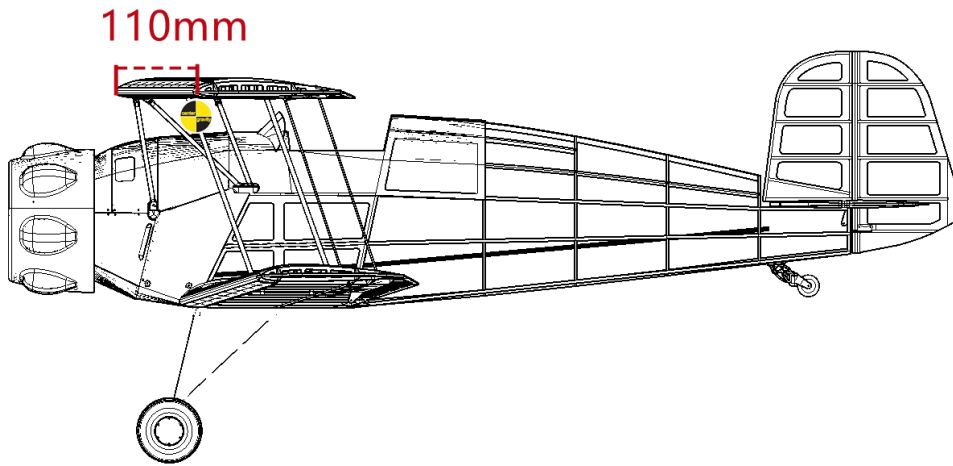

2. Horizontal stabilizer mounting angle: 0 degrees

3. Wing installation angel:

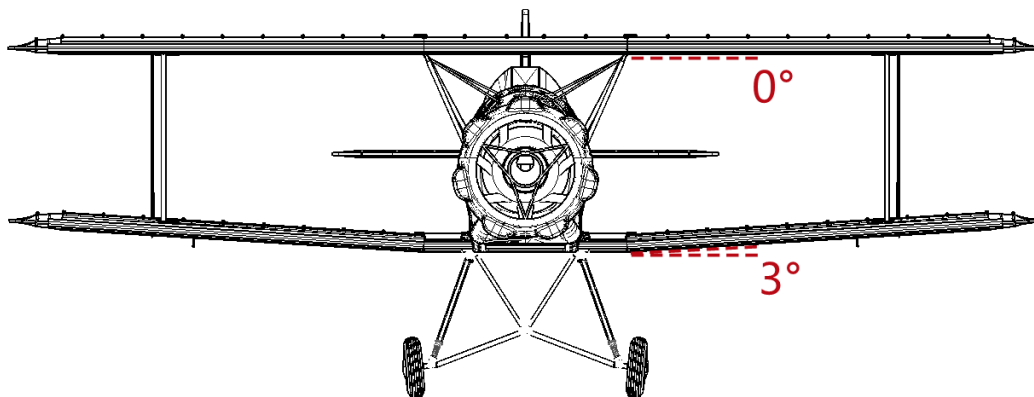

3.Control Travel	
ELEVATOR	$\pm 20^\circ$
RUDDER	$\pm 30^\circ$
AILERON	$+15^\circ -10^\circ$

Thank you!



Tony Ray's AeroModel