

Bücker JUNGMEISTER

Bü133 1/5

Bauanleitung



Modelldetails

Spannweite	1320 mm / 52.0"
Tragflaeche	41,3 sq dm / 4.13 sq ft
Leergewicht	1200 Gramm / 42.33 oz.
Fluggewicht	2200 Gramm / 77.60 oz.
Rumpflaenge	1150 mm / 45.28"
Masstab	1 / 5

Erfordert

RC-Sender mit mindestens 5 Kanaelen
2 x Servos fuer Querruder (ca. 20 Gramm)
2 x Servos fuer Hoehen- und Seitenruder (ca. 40 Gramm)
Motor System (ab ca. 600 Watt Leistung)



Tony Ray's AeroModel

BAUVORBEREITUNGEN

Hinweise und Tipps

1. Bitte lese vor dem Bau alle Hinweise und Tipps gruendlich durch.
2. Pruefe den Baukasten auf Vollstaendigkeit.
3. Bitte halte die Reihenfolge der Bauanleitung ein.
4. Schuetze die Flaechen- und Leitwerkszeichnungen durch eine duenne Klarsichtfolie.
5. Nachdem du die Bauteile ausgeloesst hast, diese vorsichtig trocken zusammenstecken und eventuell durch vorsichtig leichtes Anschleifen anpassen. Erst dann mit wenig Sekundenkleber oder Holzleim verbinden. Trockenzeit beachten.
6. Beim Fixieren von kleinen Bauteilen diese nicht mit Modellbaunadeln durchstechen, sondern seitlich fixieren. Ansonsten besteht Gefahr, dass das Holz aufspaltet.

KIT-Lieferumfang



























Holzbrettchen-Lieferumfang







Artikel:	Menge	Markierung
2.0mm Paulownia	11	A Serie: A1-A11
3.0mm Sperrholz	3	B Serie: B1-B3
2.0mm Sperrholz	4	C Serie: C1-C4
3.0mm Paulownia	4	D Serie: D1-D4
3.0mm Balsa	2	E Serie: E1-E2
1.0mm Balsa	5	F Serie: F1-F5
1.0mm Hard Sperrholz	1	G Serie: G1
5.0mm Balsa	1	H Serie: H1
1.0mm Soft Sperrholz	7	Nicht markiert

Holz Leisten und Zubehör Lieferumfang

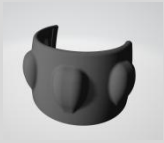
Artikel:	Menge
3 x 3mm Balsa, Laenge: 72 + 18 cm	4
6 x 6mm Balsa, Laenge: 72 + 18 cm	3
3 x 3mm Kiefer, Laenge: 72 + 18 cm	6
6 x 2mm Kiefer, Laenge: 72 + 18 cm	20
8 x 2mm Kiefer, Laenge: 72 + 18 cm	2
PVC Roehrchen (Aussen Φ : 3 mm, Innen Φ : 2 mm), Laenge: 72 cm	2
Stahl Schubstange (1,2 mm Durchmesser), Laenge: 72 cm	2
Kiefernstab mit Φ 6 mm, Laenge: 50 cm	2
Stahlkabel mit Φ 0,8 mm	5 Meter

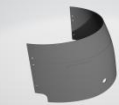
Weiter Zubehörteile:					
Artikel	Menge	Artikel	Menge	Artikel	Menge
M3 x 10 Schraube 	8	M3 Sperrzahnmutter 	2	Kupferscharnier 	6
M3 Zylinder Mutter 	4	M1.2 x 4 Schraube 	Ca.120	M3 Ø4 Hutmutter 	8
M2 x 9 Schraube 	70	M2 x 5 Schraube 	20	M2 Mutter 	45
M3 Mutter 	12	Kupferbuchse 	2	Stelling 	2
M2 x 8 Schraube 	14	M1.6 x 6 Schraube 	10	M1.6 Mutter 	10
Schmuckkarabiner 	2	Gestaengeanschluss 	2	Aluminium Pressklemme 	60
M4 x 15 Schraube 	8	Kunststoff Scharnier 	9	M2 Kugelring Gabelkopf 	6
M2 x 30 Gewindestange 	4	M3 x 60 Gewindestange 	4	M3 x 30 Gewindestange 	8
Feder 	2	M3 Magnet 	8	M1 x 3 Schraube 	50

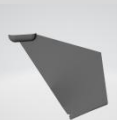
Hardware					
Artikel	Menge	Artikel	Menge	Artikel	Menge
Spornrad Set 	1	3 Zoll Reifen 	2	M2 x 45 Gewindestange 	2

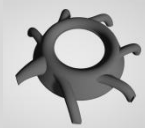
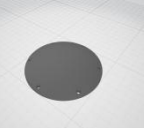
Kunststoffteile					
Artikel	Menge	Artikel	Menge	Artikel	Menge
Motorhaube unten 	1	Motorhaube oben 	1	Obere Verkleidung 	1
Seitliche Verkleidung 	2 (Links+Rechts)	Seitliche Verkleidung 	2 (Links+Rechts)	Abdeckung 	2 (Links+Rechts)
Auspuffattrappe 	1	Radabdeckung 	2		

Weiteres Zubehör	
1:1 Bauzeichnung	2
Decals Aufkleber	1
Pu-Kunstleder ca. 15 x 15 cm	1
Lasercut PVC Platte	1
Aluminiumblech 0,3 mm, 20 x 10 cm	3

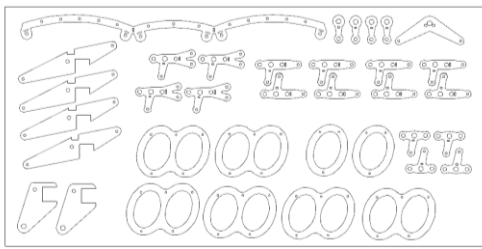
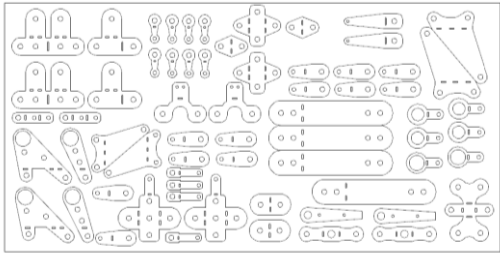
Lasergeschnittene Bauteile aus Metall	
	

Metallröhrchen Lieferumfang		
	Artikel	Menge
Für Fahr- gestell	Stahlrohr Ø6 mm, Länge ca. 127 mm, Bohrung Ø2 mm an einem Ende	2
	Stahlrohr Ø4 mm, Länge ca. 150 mm, Bohrung Ø2 mm an beiden Enden, vorgebogen	2
	Aluminiumrohr Ø3 mm, Länge ca. 168 mm	2
	Aluminiumrohr Ø4 mm, Länge ca. 100 mm	2
	Aluminiumrohr Ø3 mm, Länge ca. 137 mm	1
Für Verstre- bungen	Aluminiumrohr Ø4 mm, Länge ca. 145 mm	2
	Aluminiumrohr Ø4 mm, Länge ca. 170 mm	2
	Aluminiumrohr Ø4 mm, Länge ca. 131 mm	2
Für Flügel- verbinder	Aluminiumrohr Ø6/4 mm, Länge 260 mm	4



Teileübersicht

Bauteil Nummer	Holzplattenummer	Bauteil Nummer	Holzplattenummer
1. Rumpf		F4A	B1
S6	B1	B1	C2
S7	C1	FC1	Unmarkiert 1.0mm Sperrholz
S7B	E1	FC2	Unmarkiert 1.0mm Sperrholz
S7C	H1	FC4	Unmarkiert 1.0mm Sperrholz
F4	D4	FC5	Unmarkiert 1.0mm Sperrholz
T4	B1	FC6	F4
B2	B3	FC7	F4
B2A	B3	2. Leitwerk	
F5	B1	V1	A10
F2A	B2	V1A	A9
T3	C3	V2	D3
F3	D4	V3	E2
S4	B2	V4	E2
S3	B1	V5	E2
F2	D2	V6	E2
S5	B1	V7	E2
T2	B2	V1A	E2
F1	B2	V1B	E2
F1A	B2	H6	D2
T1	D1	R3	D3
S1	E1	R8	A9
FR1	C2	R9	A9
FR1A	C2	R10	A10
FR1B	C2	R1	E1
FR1C	C2	R2	E1
FR2	C2	R11	A9
FR3	G1	R12	A8
F5B	F5	H1	D3
F6	C2	H2	A7
F7	C3	H4	E1
F8	C3	H5	E1
F9	C2	H2A	D3
F6B	A9	H2B	F4
F9A	D2	H3	D2, E1
F10	B3	E3	D3
S2	D1	E4	A7, A8
S2A	D1	E1	E1
B3	D1	E2	E1
F9B	C2	E5	E1

Teileübersicht

Bauteil Nummer	Holzplattenummer	Bauteil Nummer	Holzplattenummer
E6	E1	W5	C4
E7	E1	W6	C4
E8	E2	R1A	C4
E10	D2	J1	B3
E9	A4	J2	B3
3. Flügelmittelteil		WC3	F2, F3
CR1	B3	WC4	F2, F3
CR1A	G1	WC5	F3
CR1B	C2	W3C	H1
CR2	D3	8. Oberflügel	
CR3	D3	W1-TOP	A1, A3
CR4	C3	W2-TOP	A1, A3
WC1	F4	R1	C4
WC1UP	F4	Übrige Flügelrippen	A1~A9
Holz-Flügelstreben	C3, C4	W3	C4
4. Kabinentüren und Instrumentenbrett		W7	A1, A2
HD1	G1	R0	A9
HD2	B3	AL7	B3
CK1	A11	AL4	G1
CK2	A11	R1A	C4
CK3	G1	J1	B3
CK4	G1	J2	B3
5. Fahrwerk		WC1	F1, F2
LD4	D3	WC5	F3
LD1	D3	9. Querruder	
LD2	D3	AL1	Unmarkiert 1.0mm Sperrholz
LD3	D3	AL2	A2, A4
LD5	D3	AL3	A4
LD6	D3	AL5	G1
7. Unterflügel		AL6	Unmarkiert 1.0mm Sperrholz
W1	A1, A3	AL7	G1
W2	A1, A3	AL8	G1
R1	C4		
Übrige Flügelrippen	A1~A9		
W3B	C4		
W7	A1, A2		
R0	A9		
AL7	B3		
AL4	G1		
W4	C4		

1.MONTAGE - RUMPF

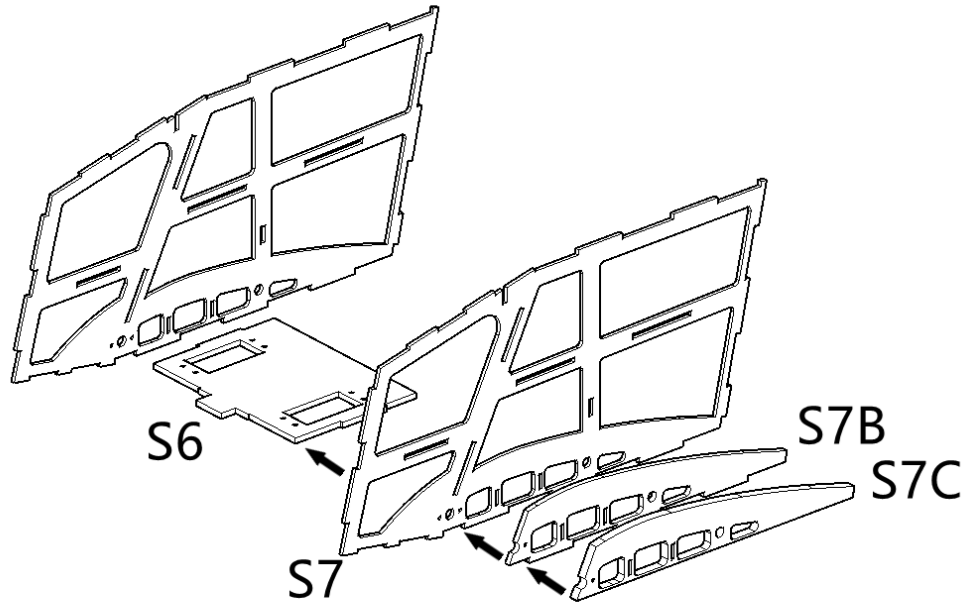

Schritt 1

Schritt 2

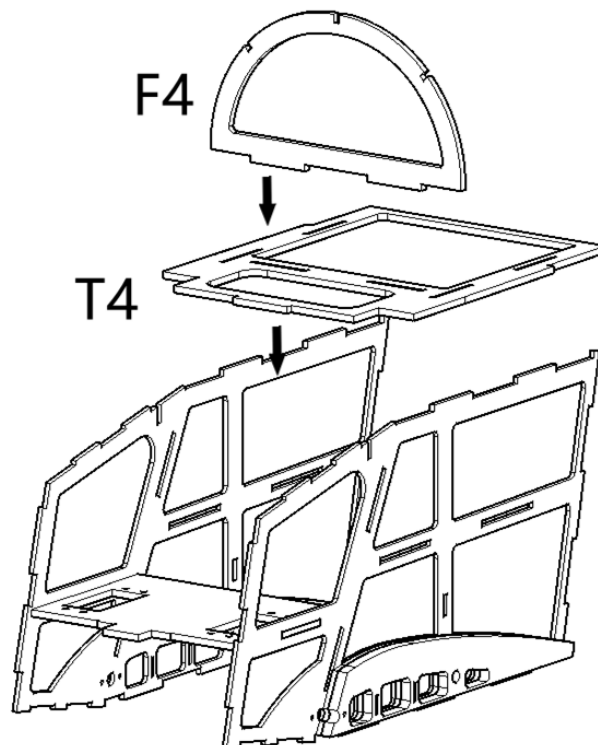

Schritt 3

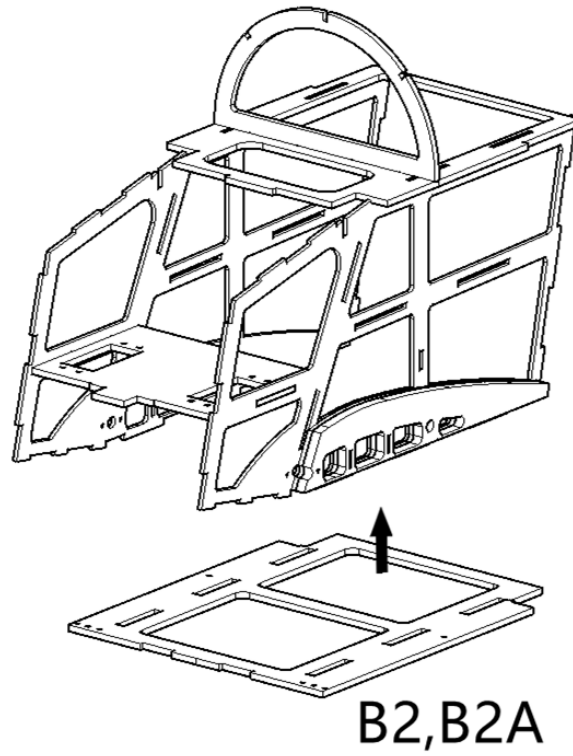

Schritt 4

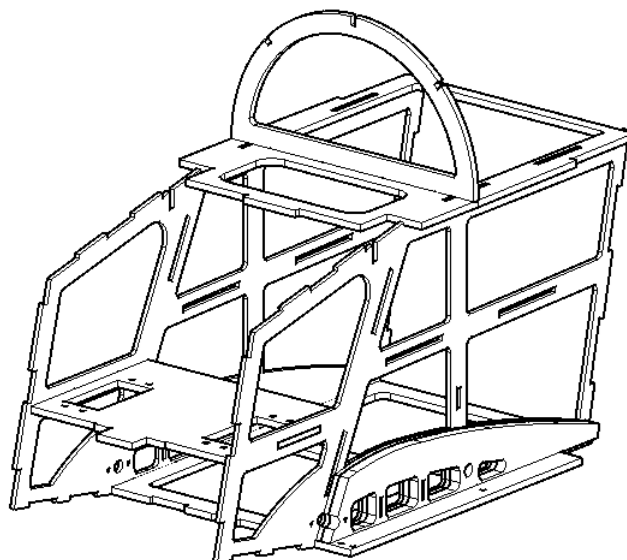

Schritt 5

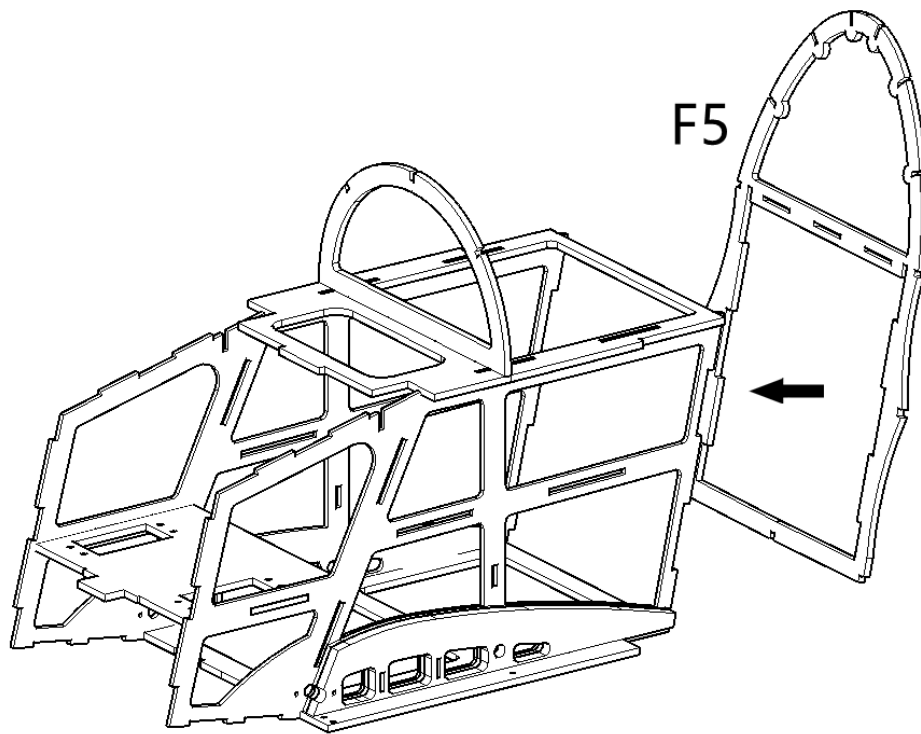

Schritt 6

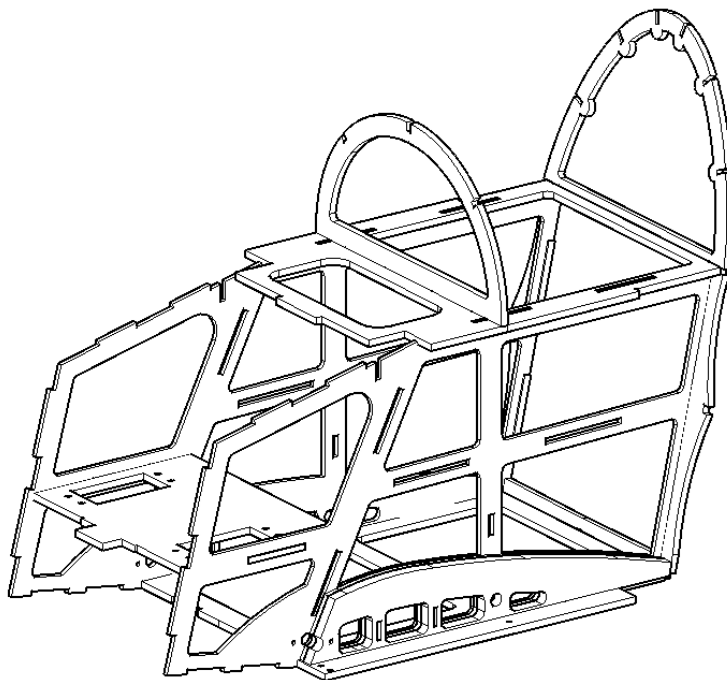

Schritt 7

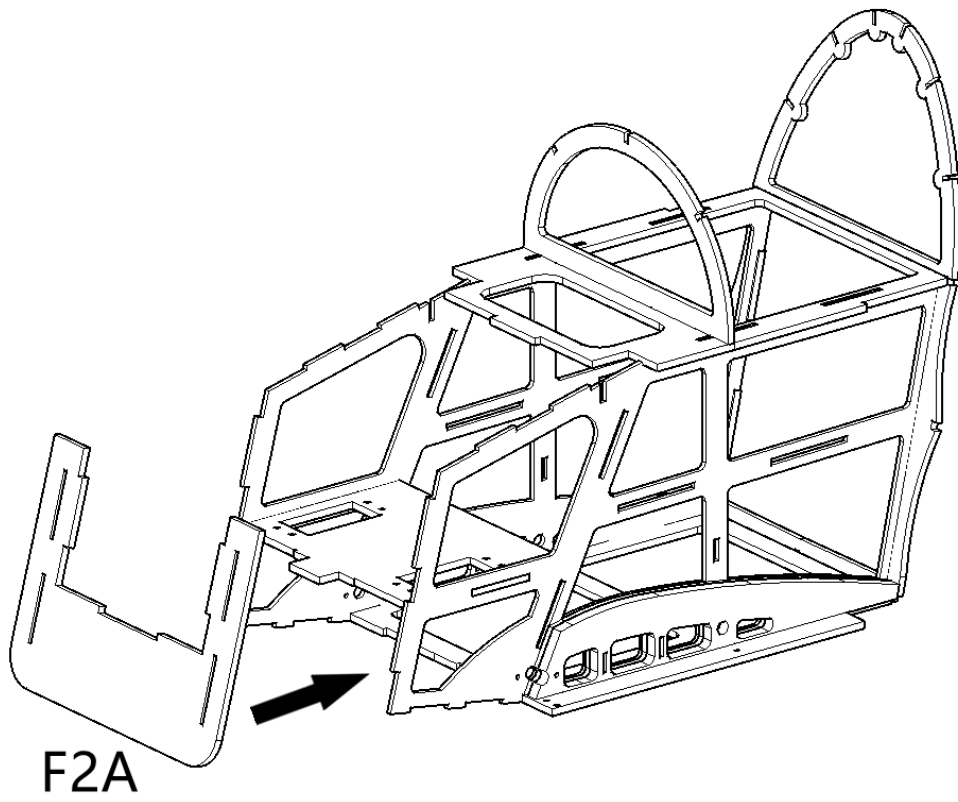

Schritt 8

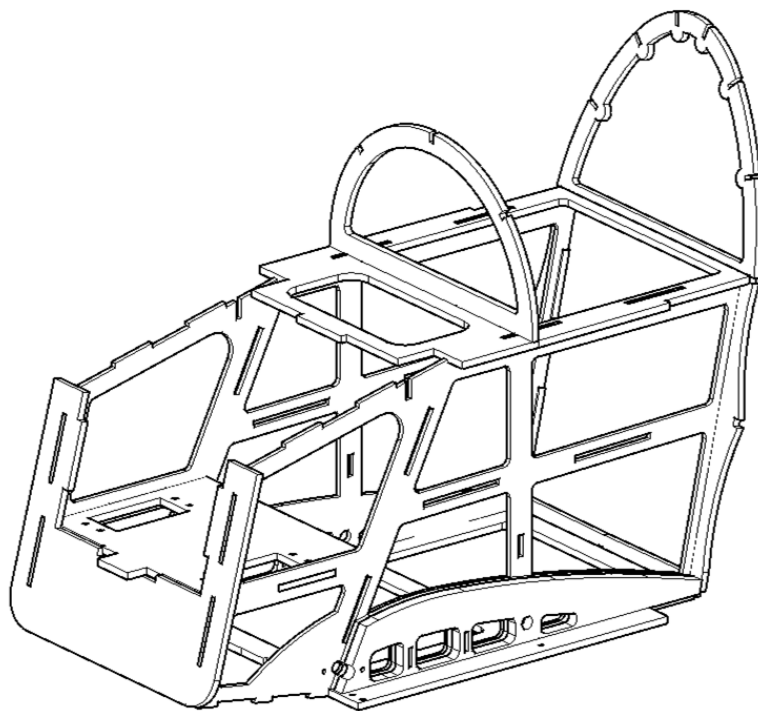

Schritt 9

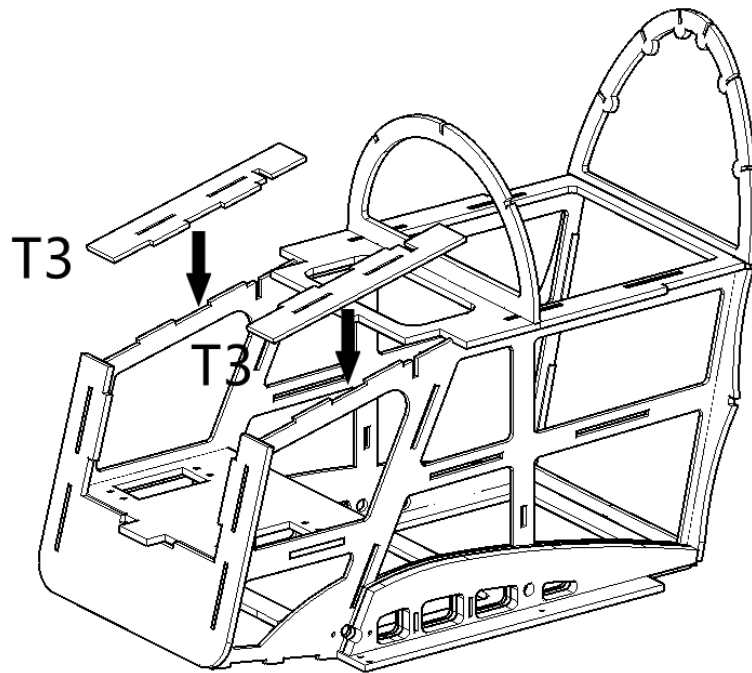

Schritt 10

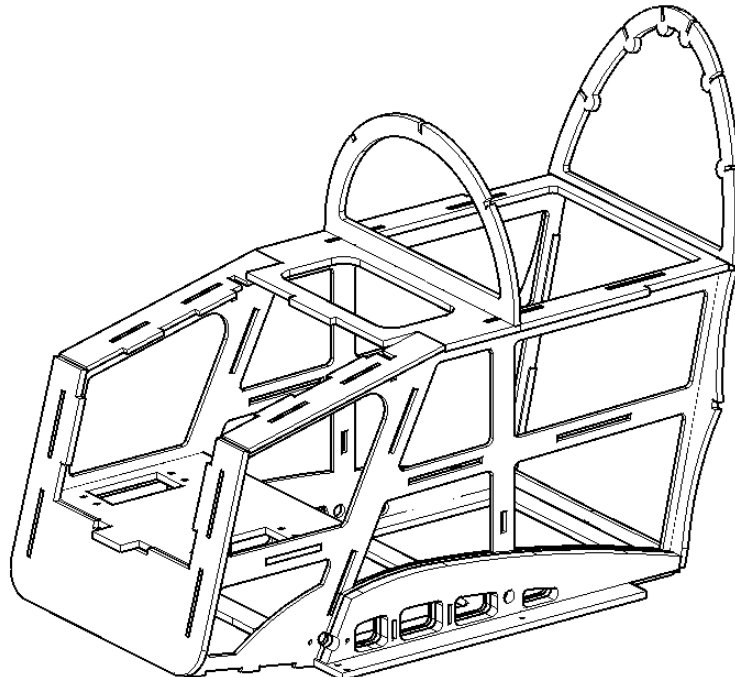

Schritt 11

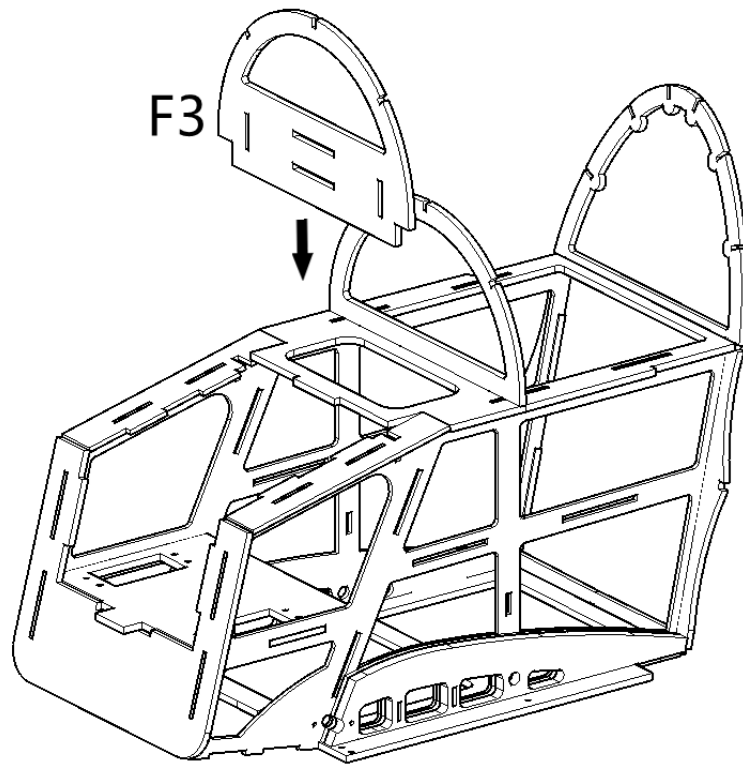

Schritt 12

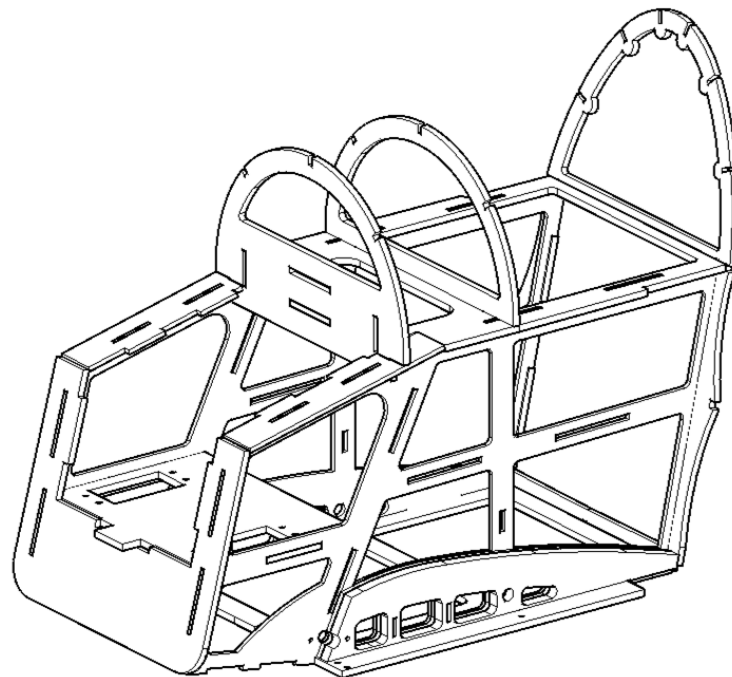

Schritt 13

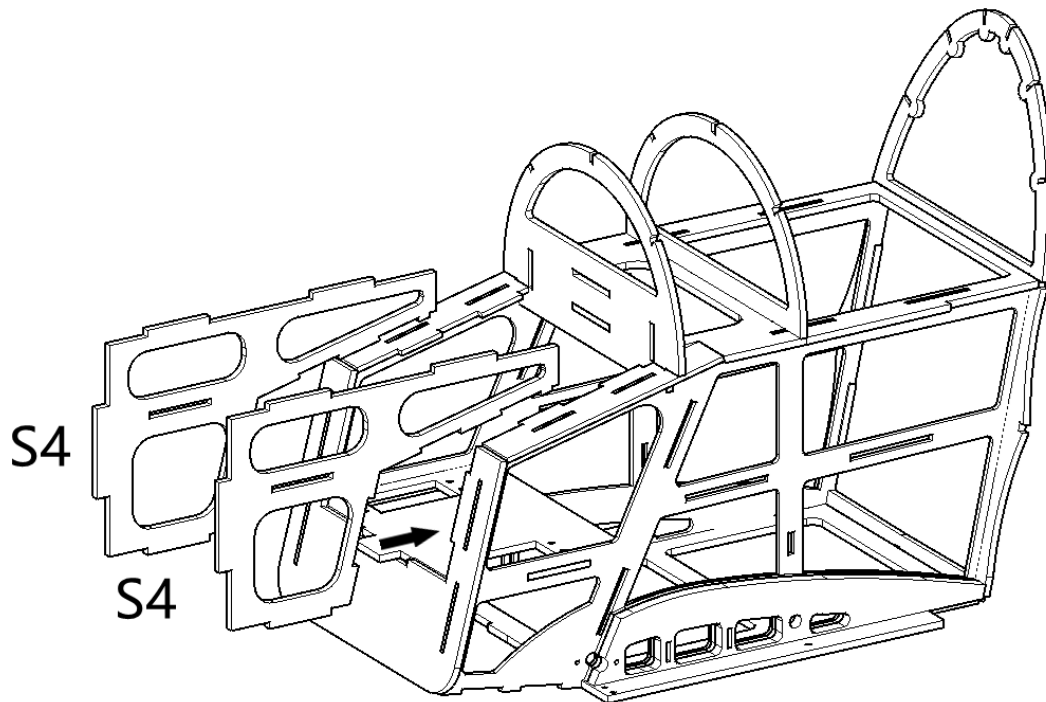

Schritt 14

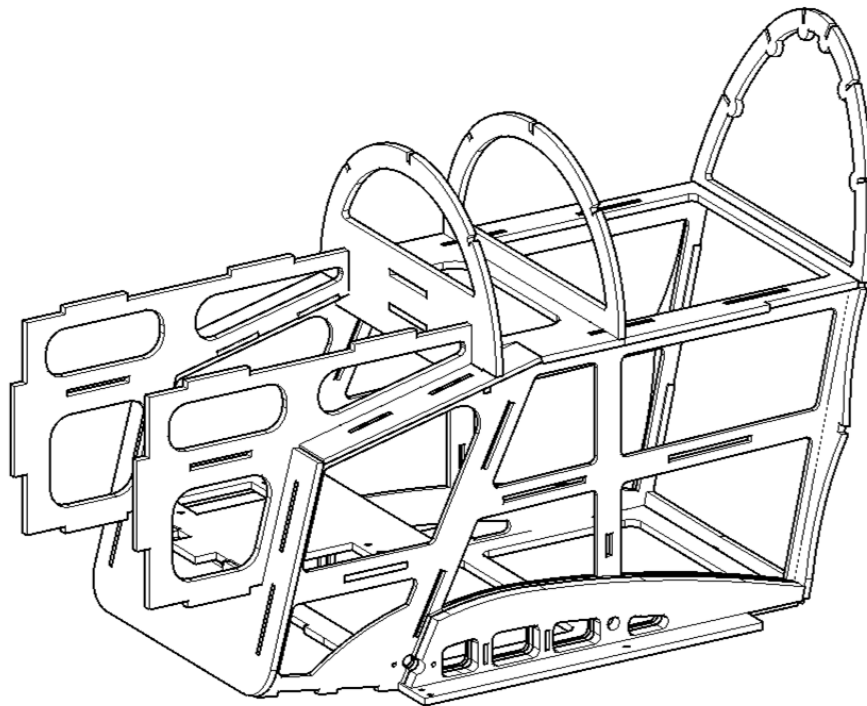

Schritt 15

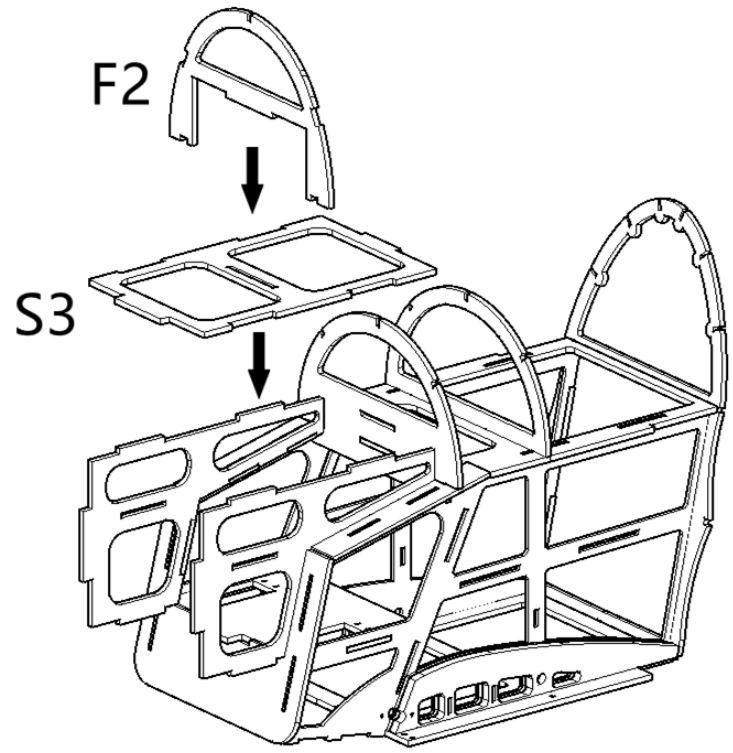

Schritt 16

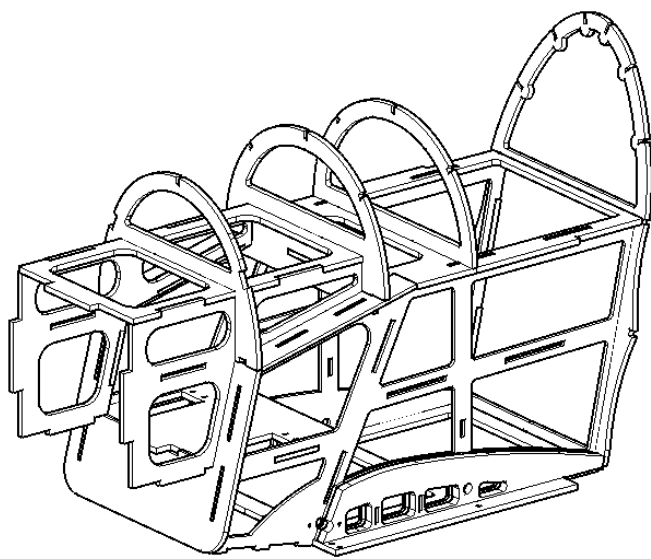

Schritt 17

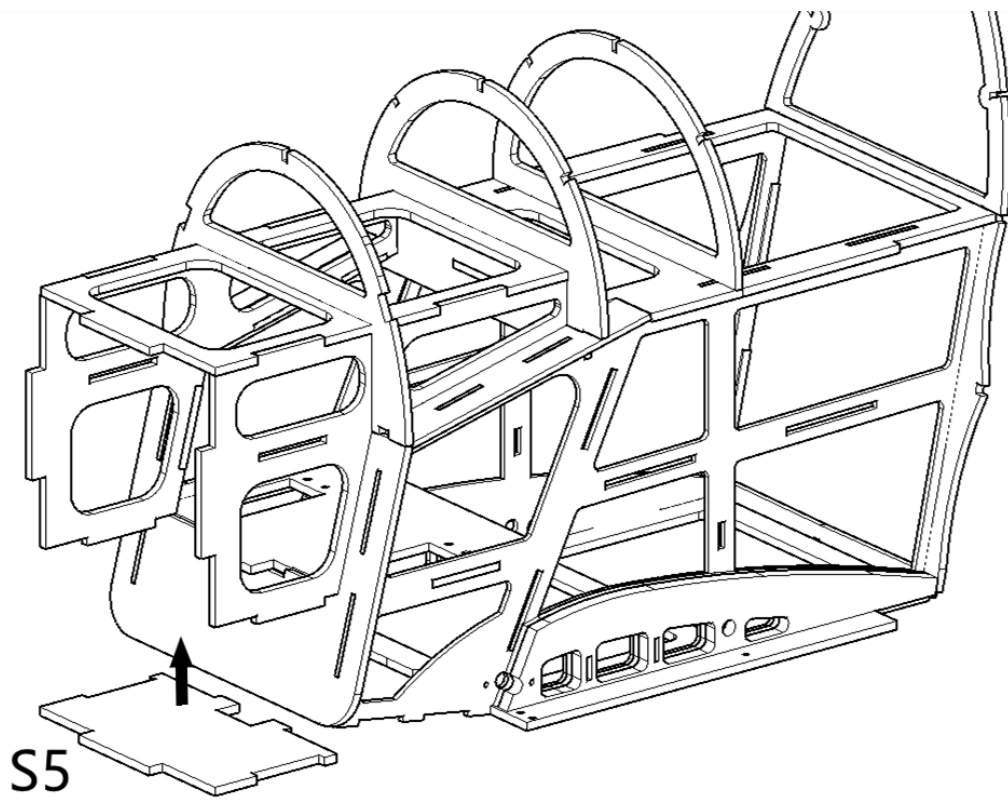

Schritt 18

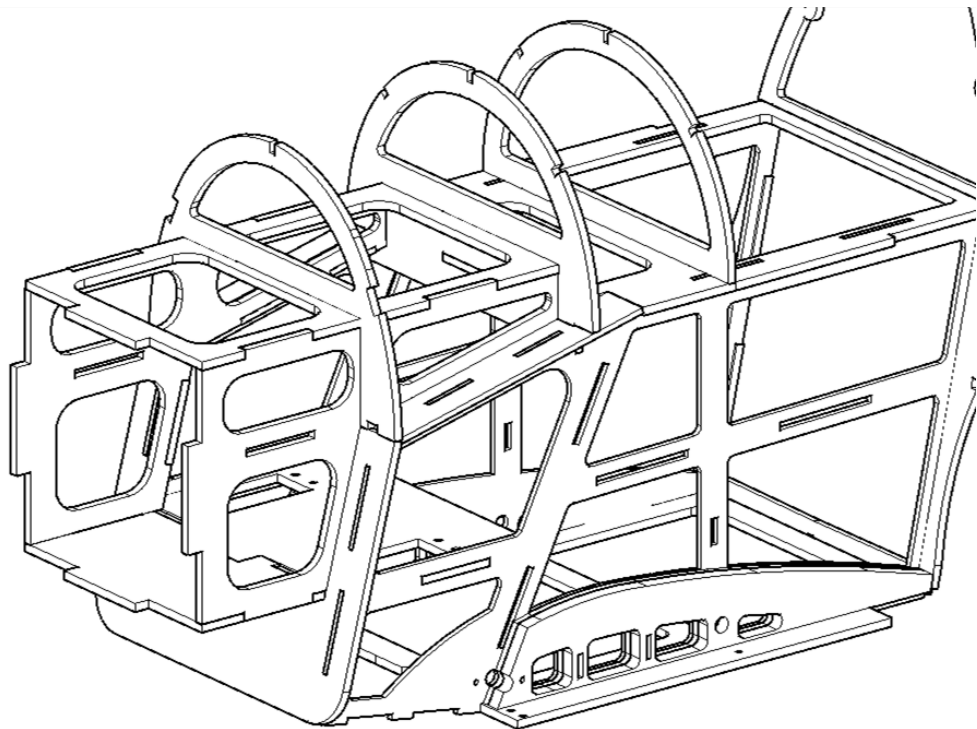

Schritt 19

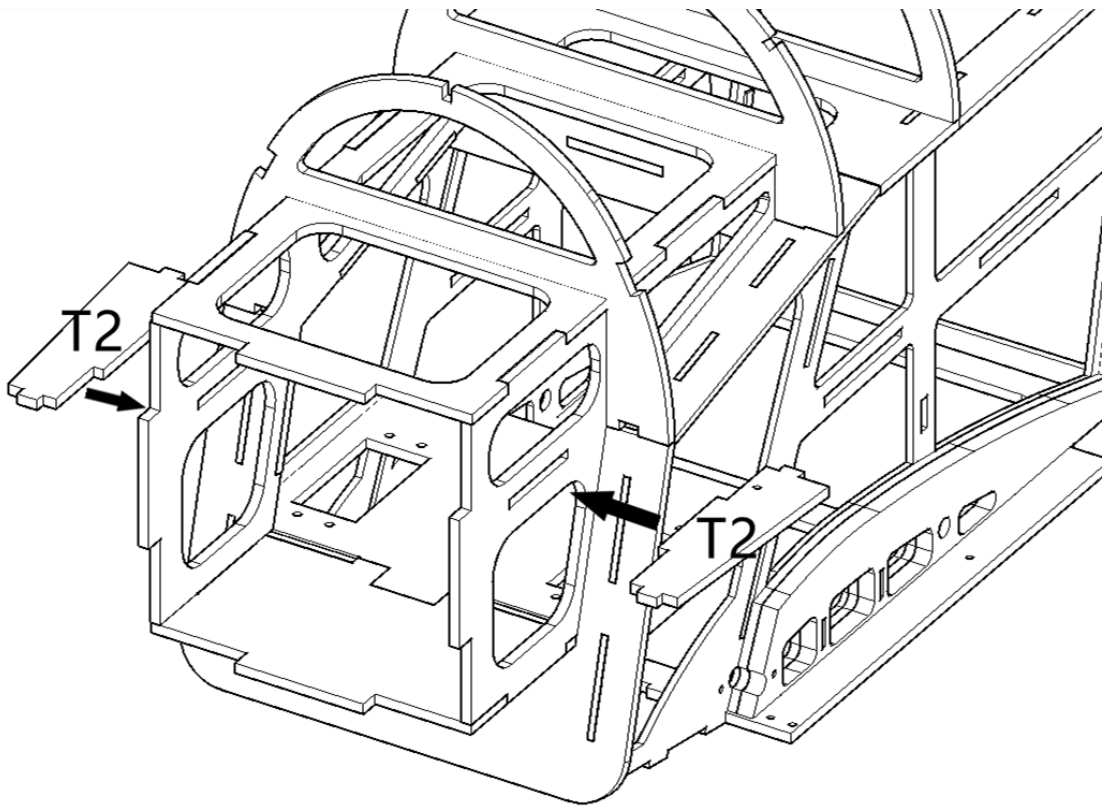

Schritt 20

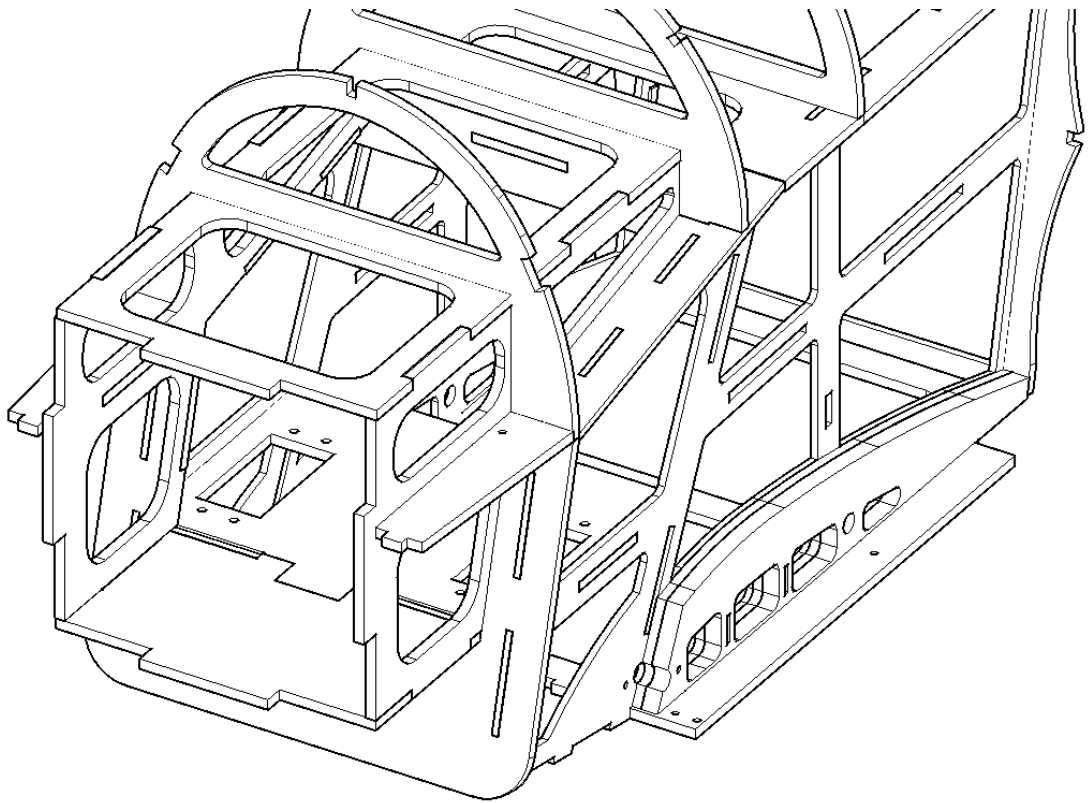

Schritt 21

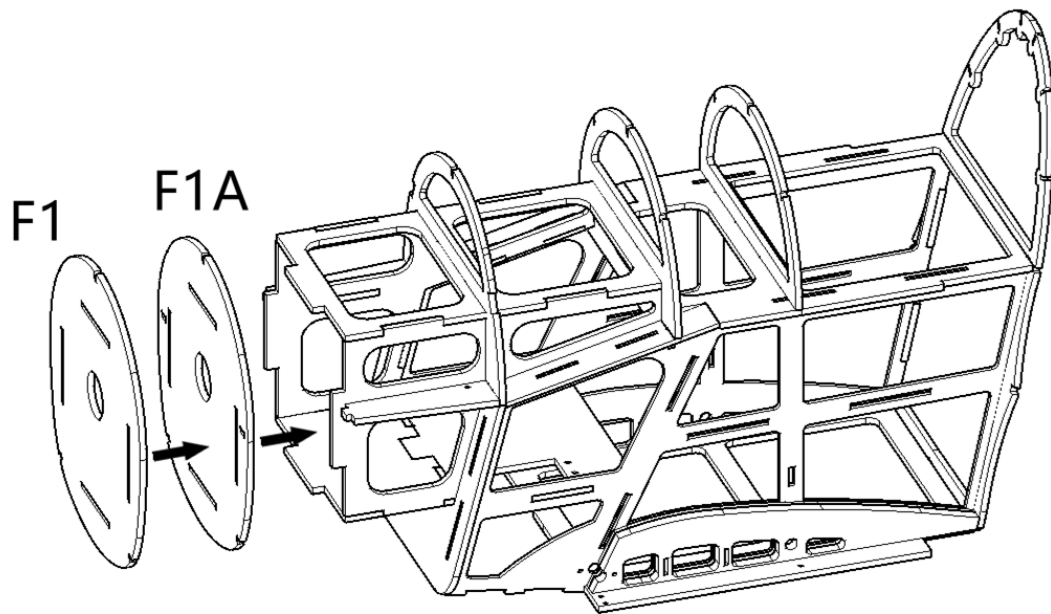

Schritt 22

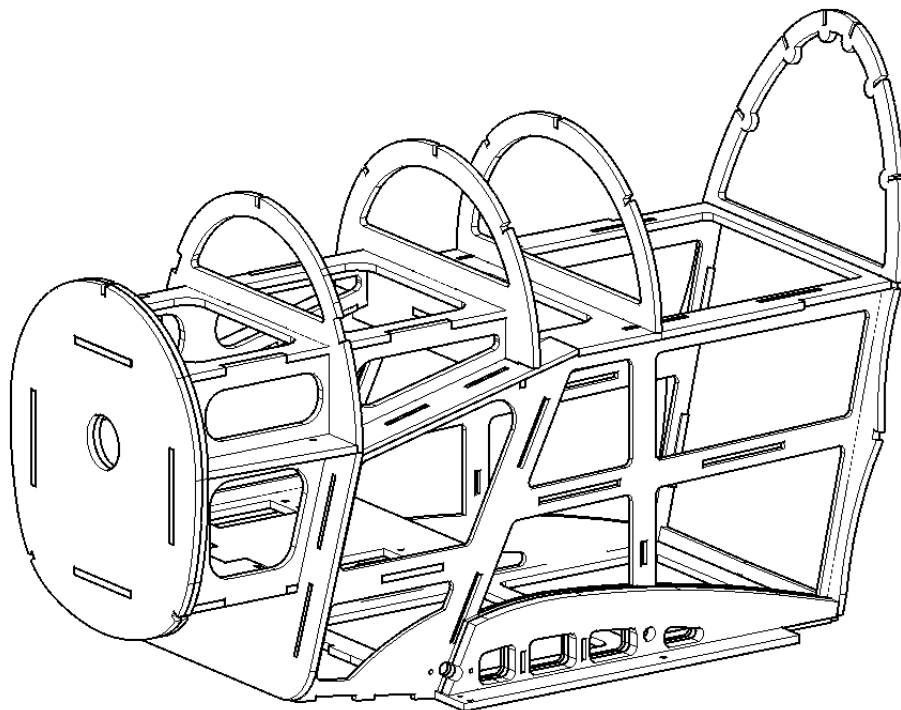

Schritt 23

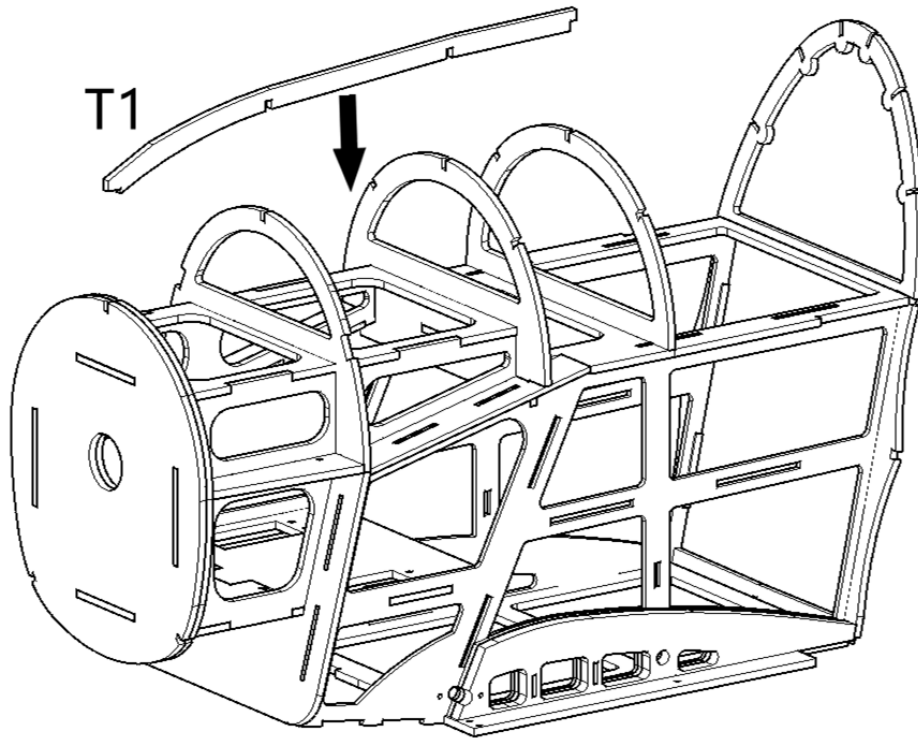

Schritt 24

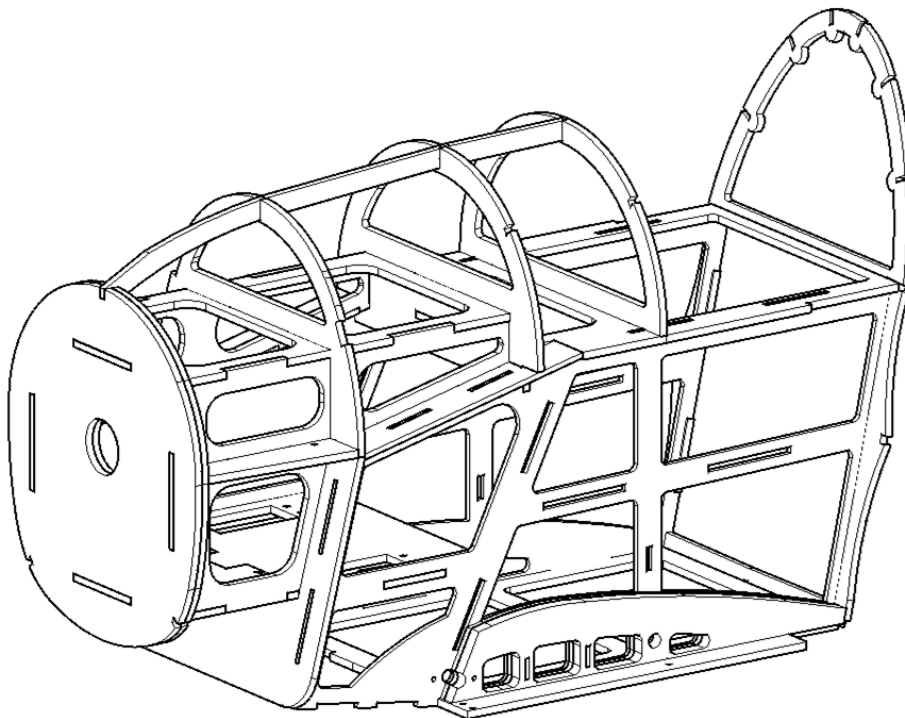

Schritt 25

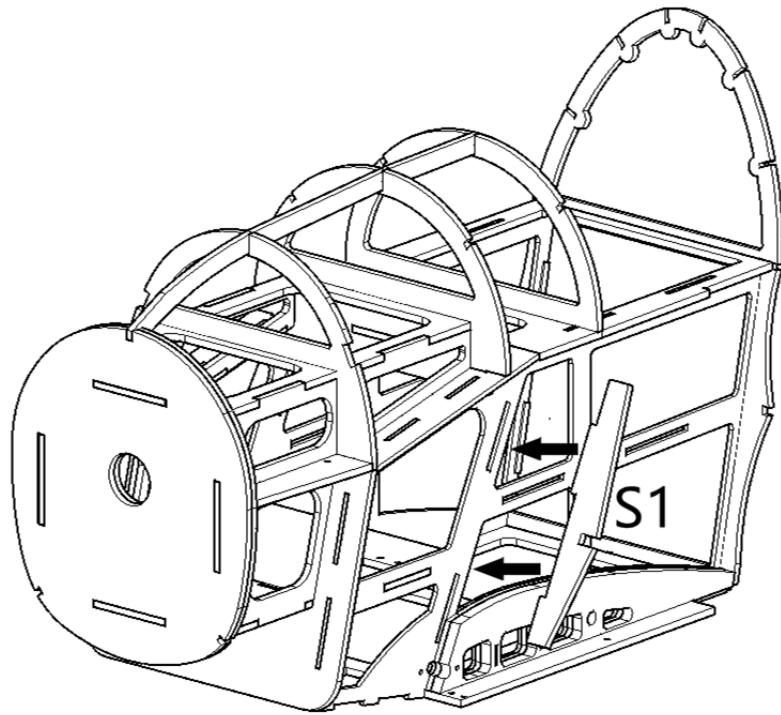

Schritt 26

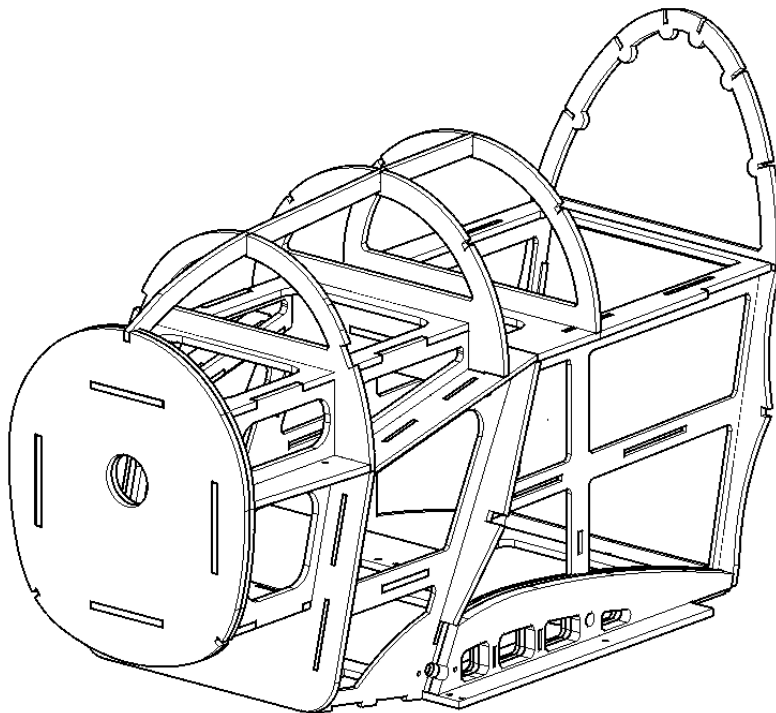

Schritt 27

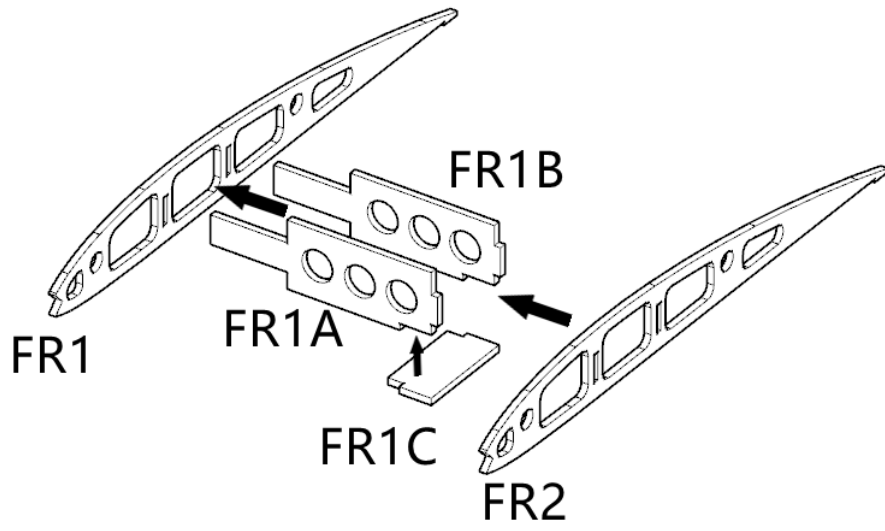

Schritt 28

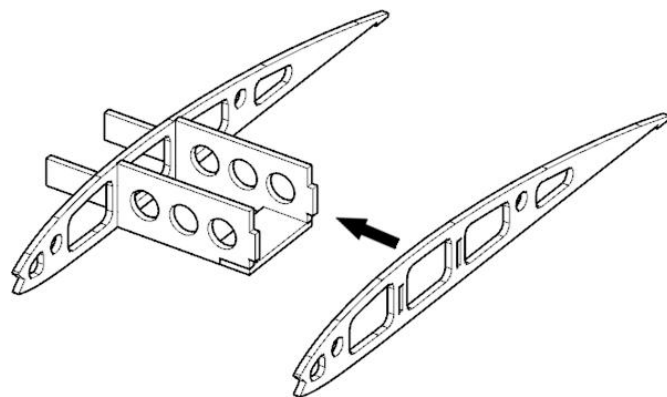

Schritt 29: 6 x 6 mm Balsa Leisten

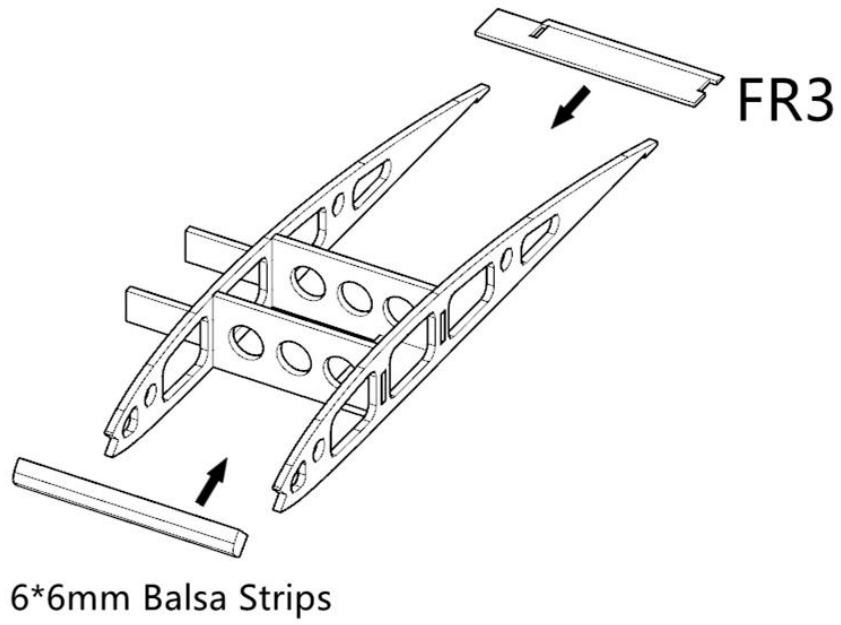

Schritt 30

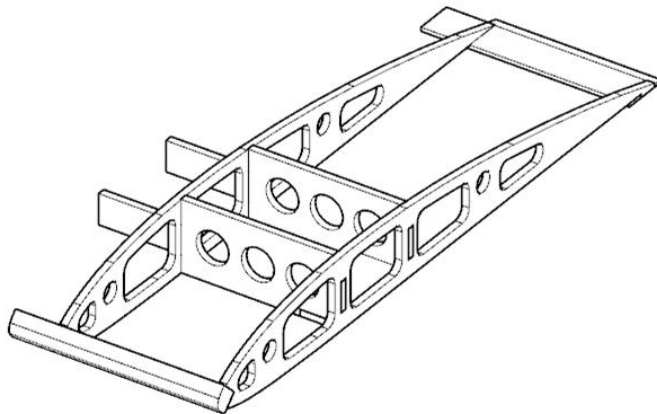

Schritt 31

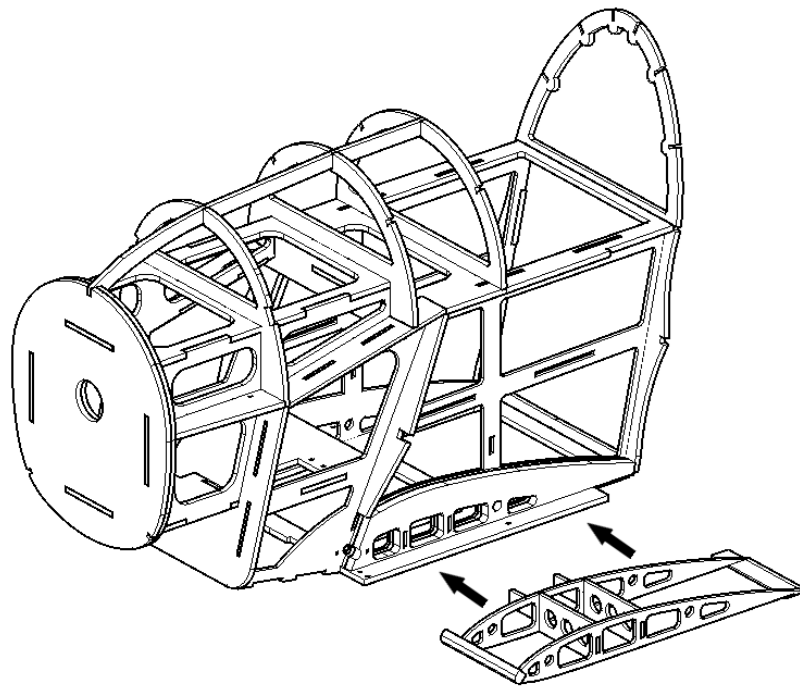

Schritt 32

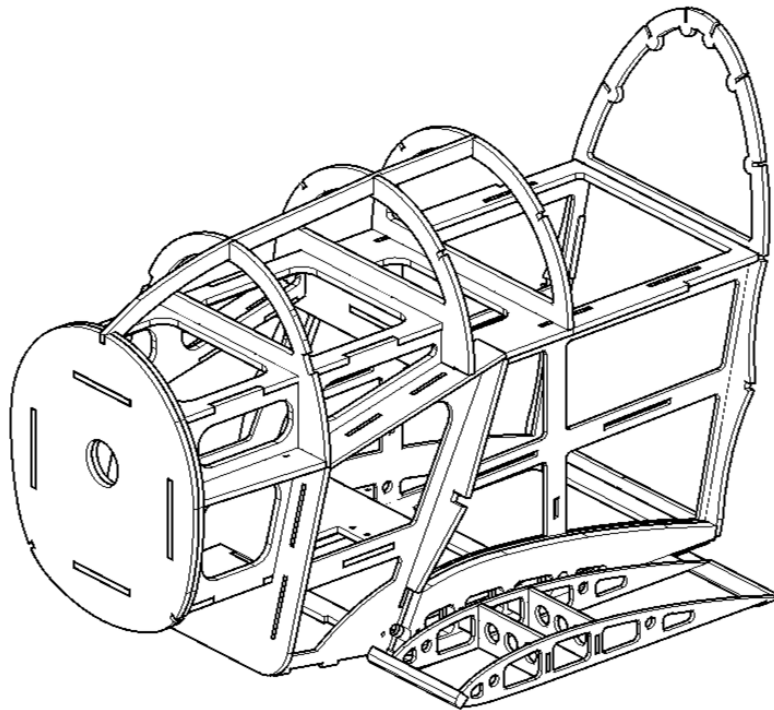

Schritt 33

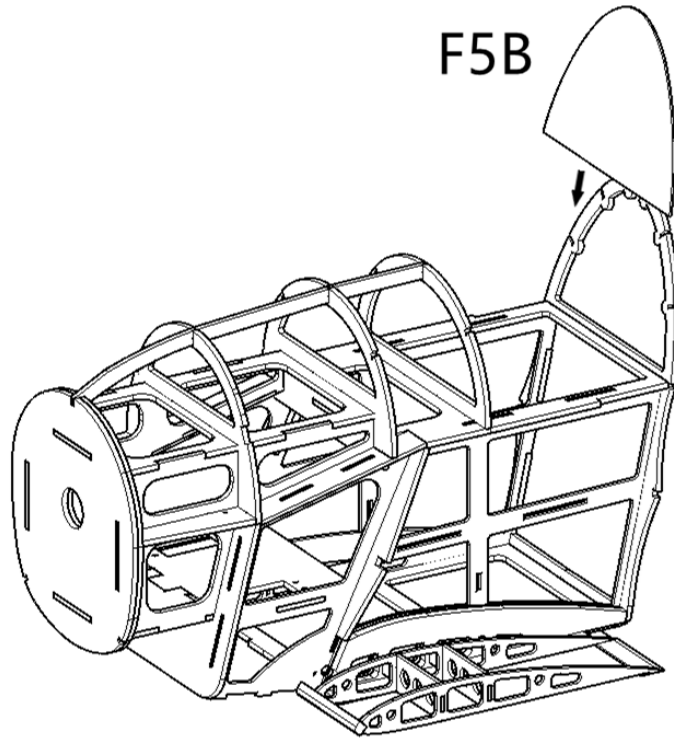

Schritt 34

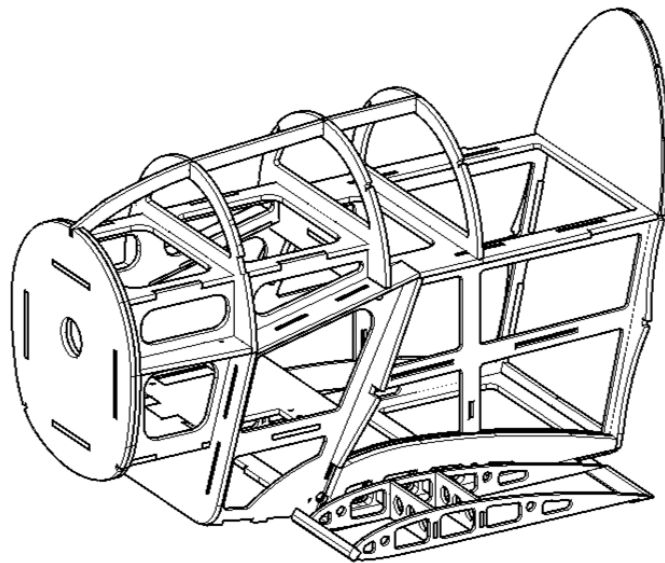

Schritt 35

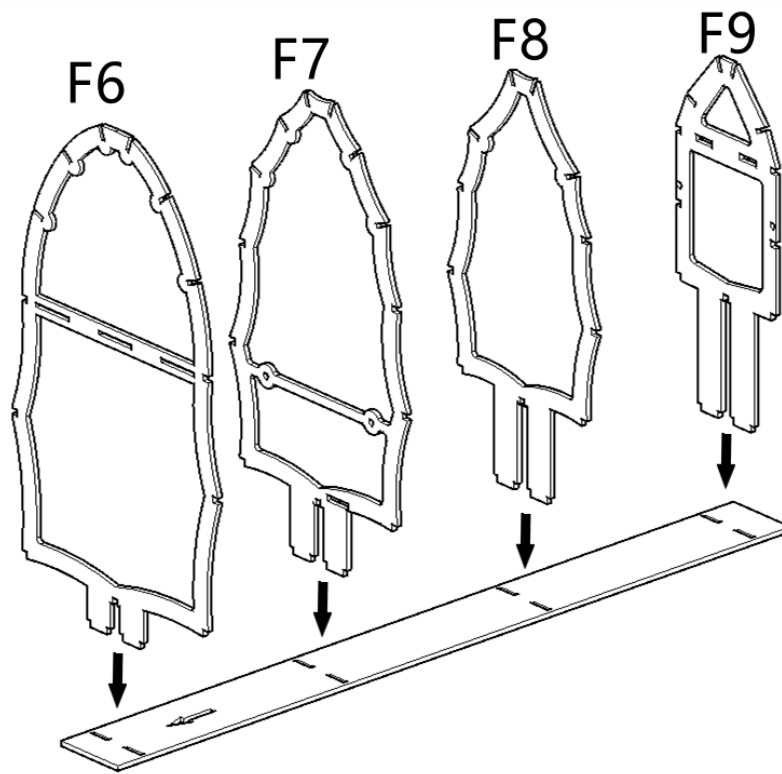

Schritt 36

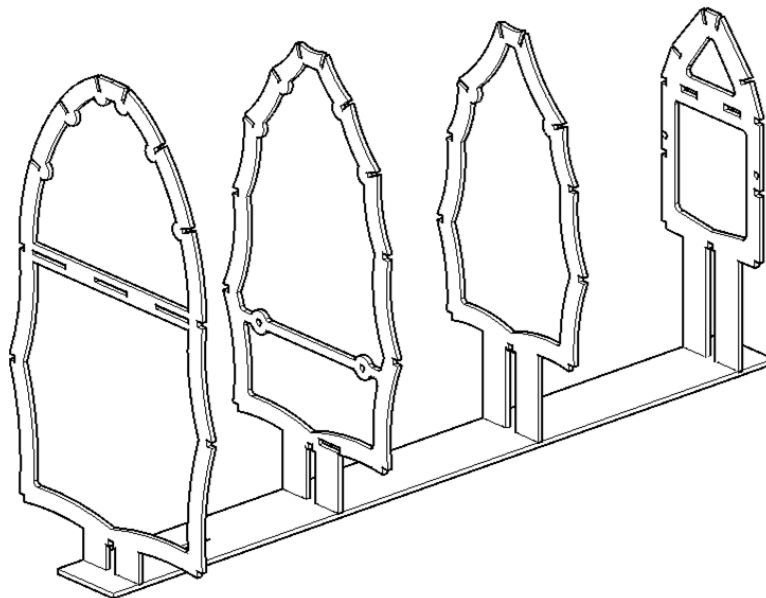

Schritt 37

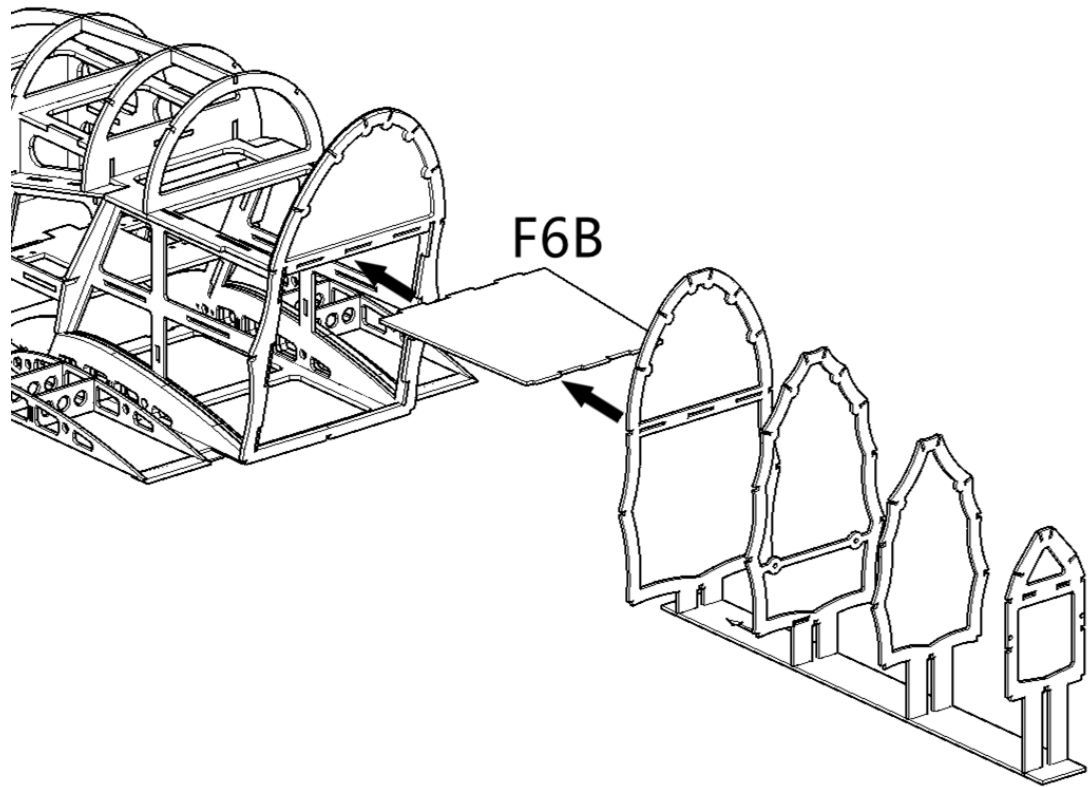

Schritt 38

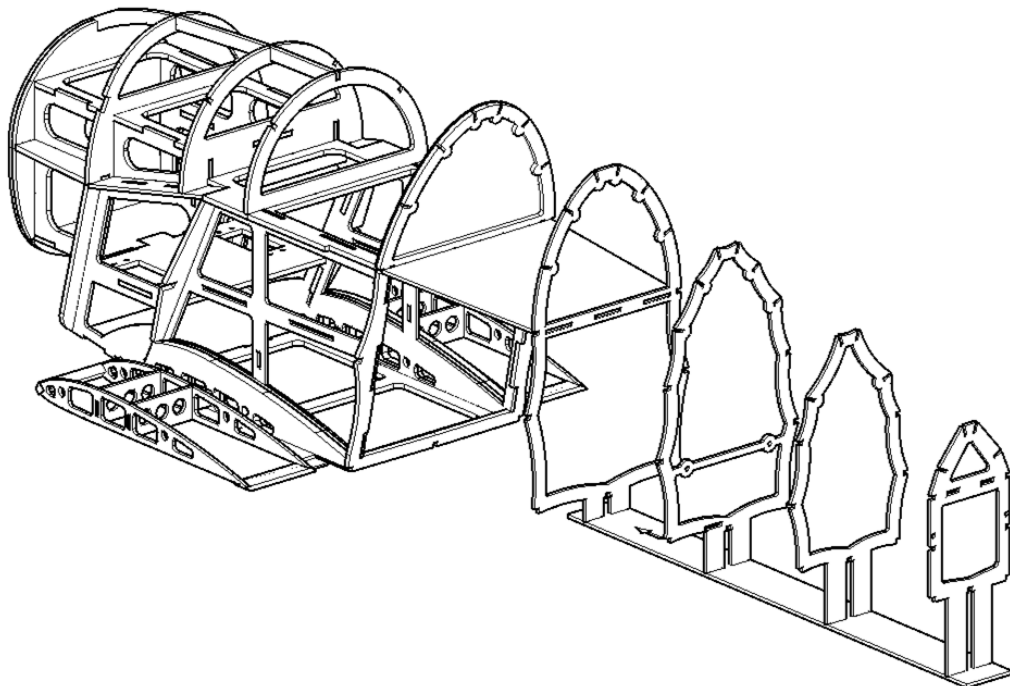

Schritt 39

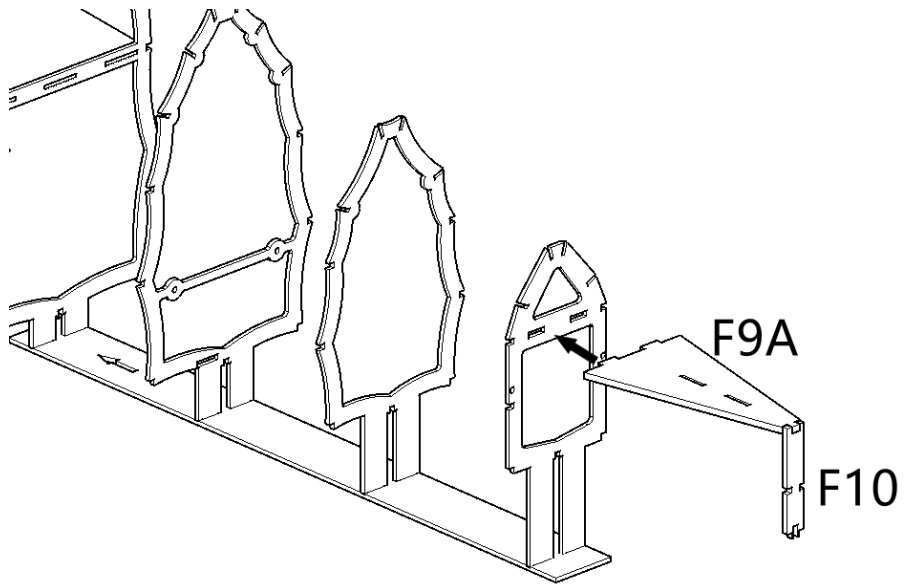

Schritt 40

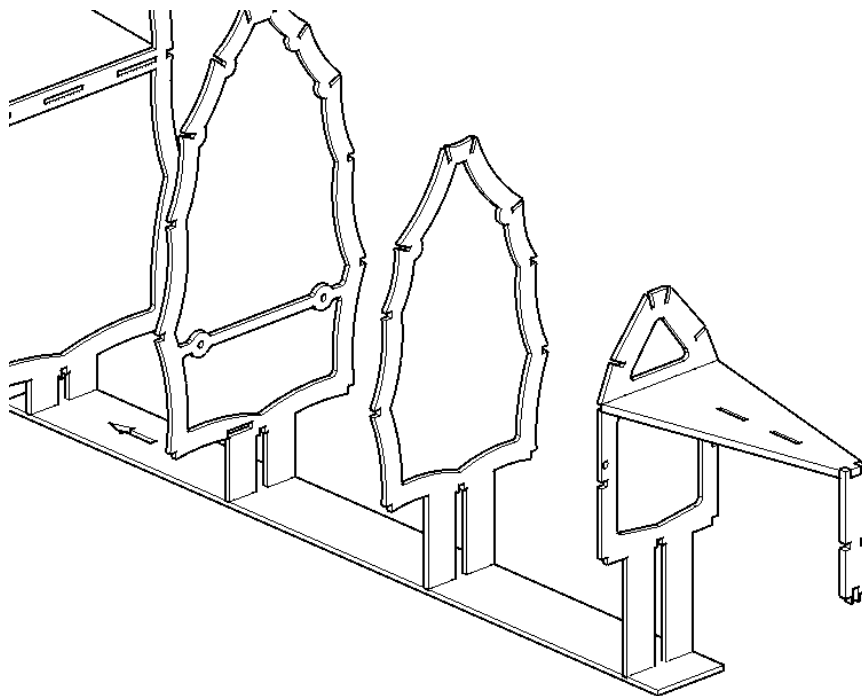

Schritt 41

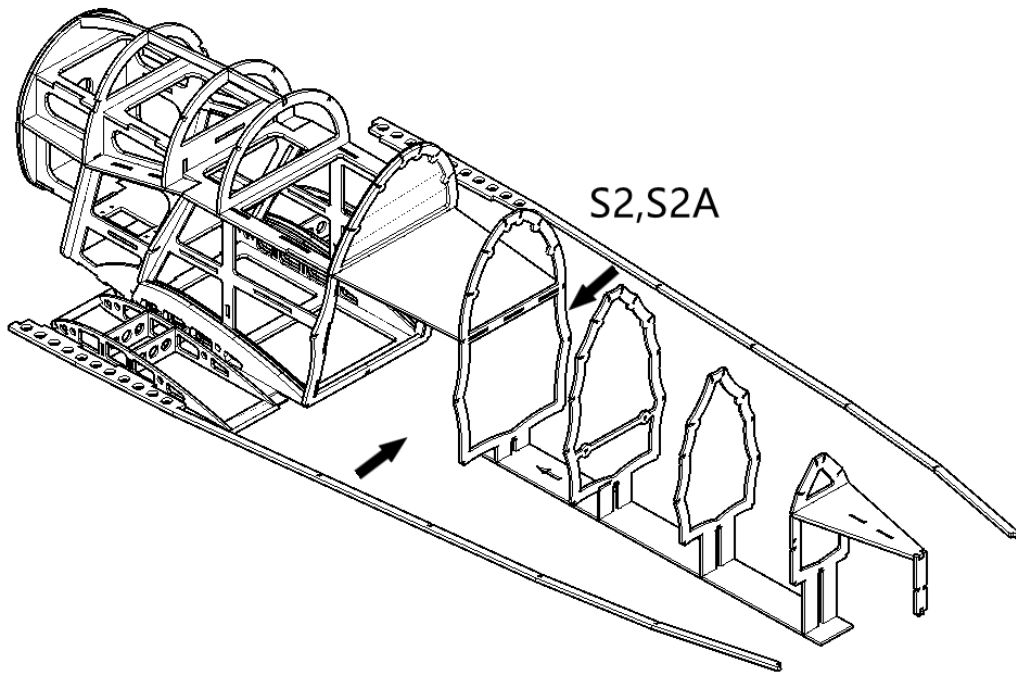

Schritt 42

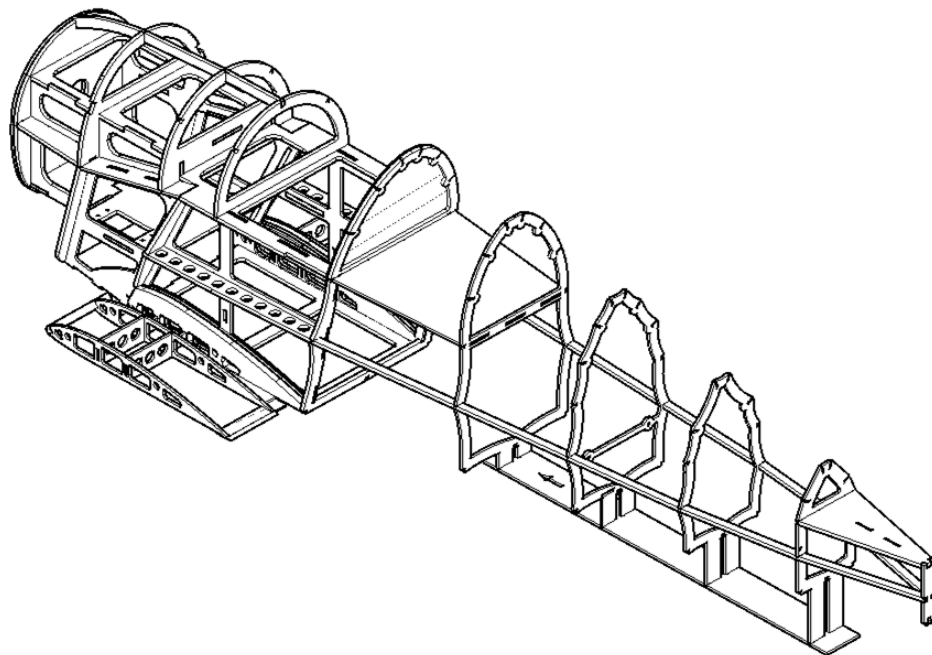

Schritt 43: 3 x 3 mm Kiefernleisten

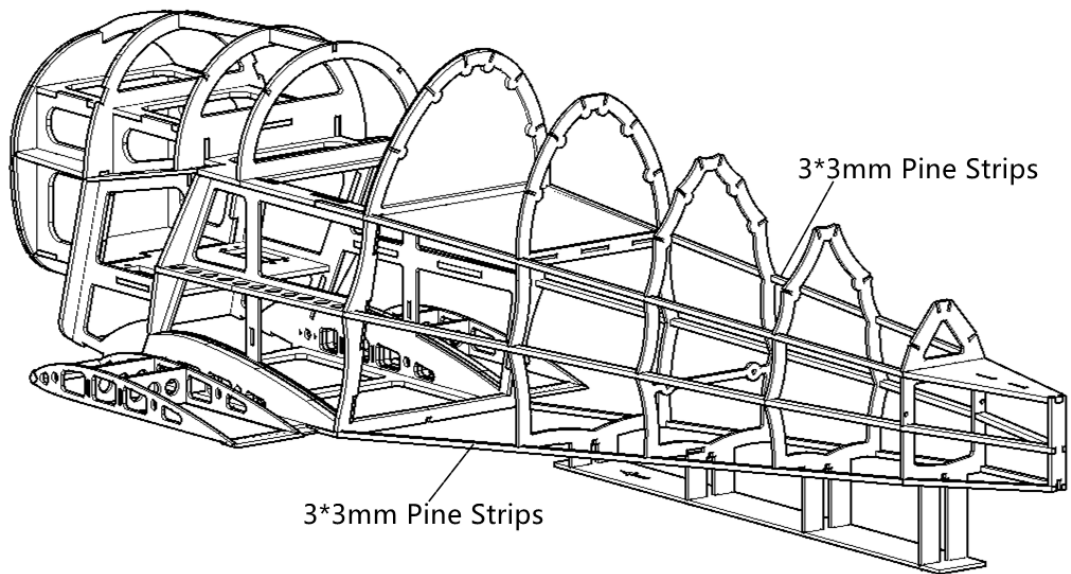

Schritt 44: 6 x 2 mm Kiefernleisten

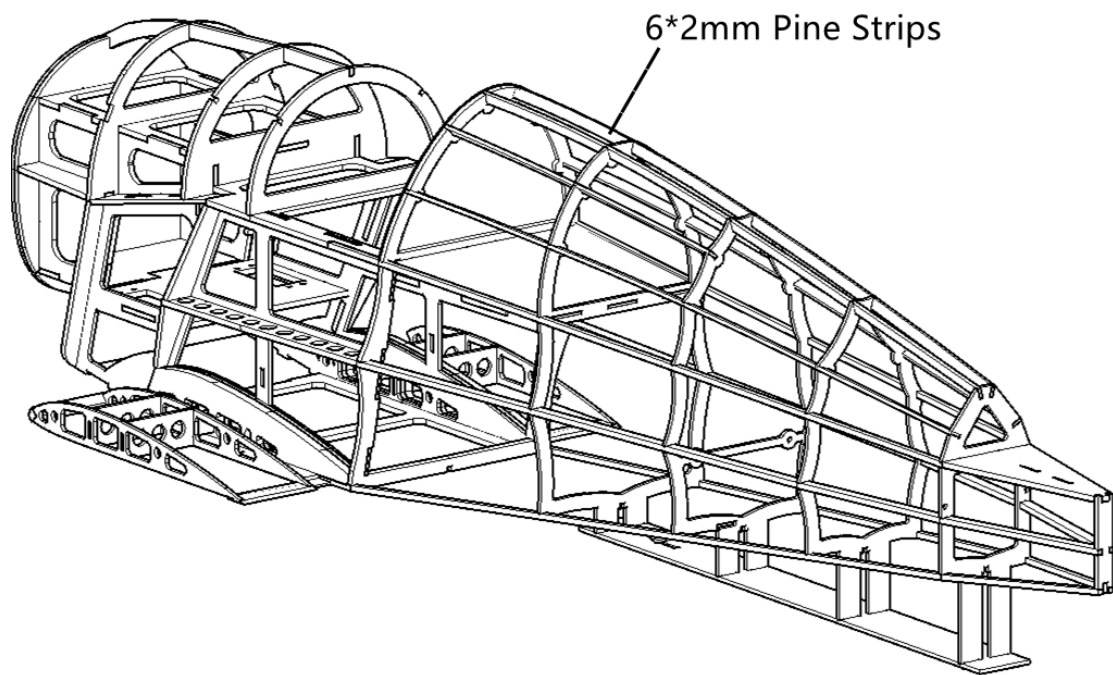

Schritt 45

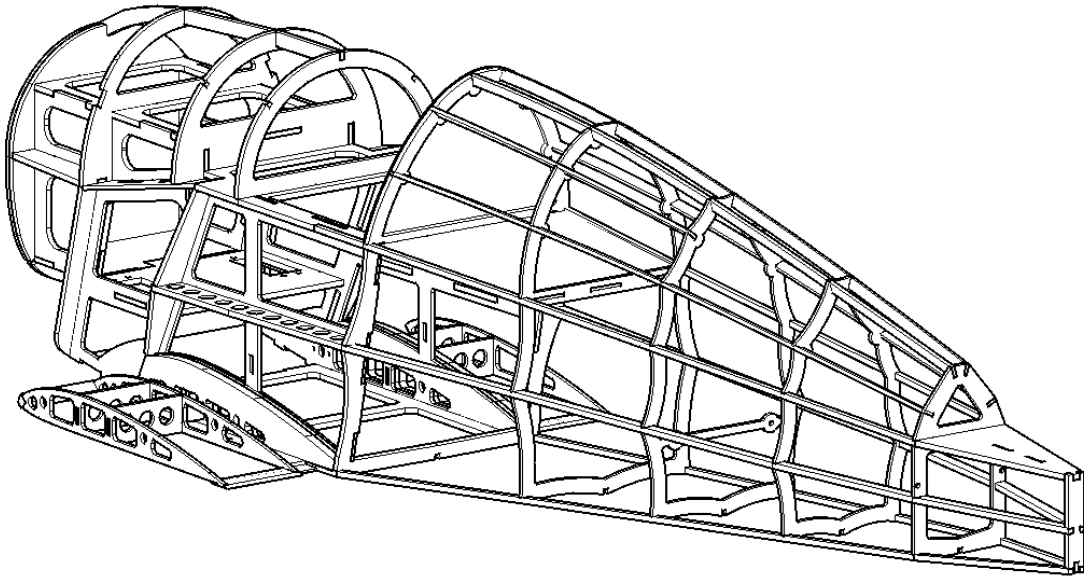

Schritt 46

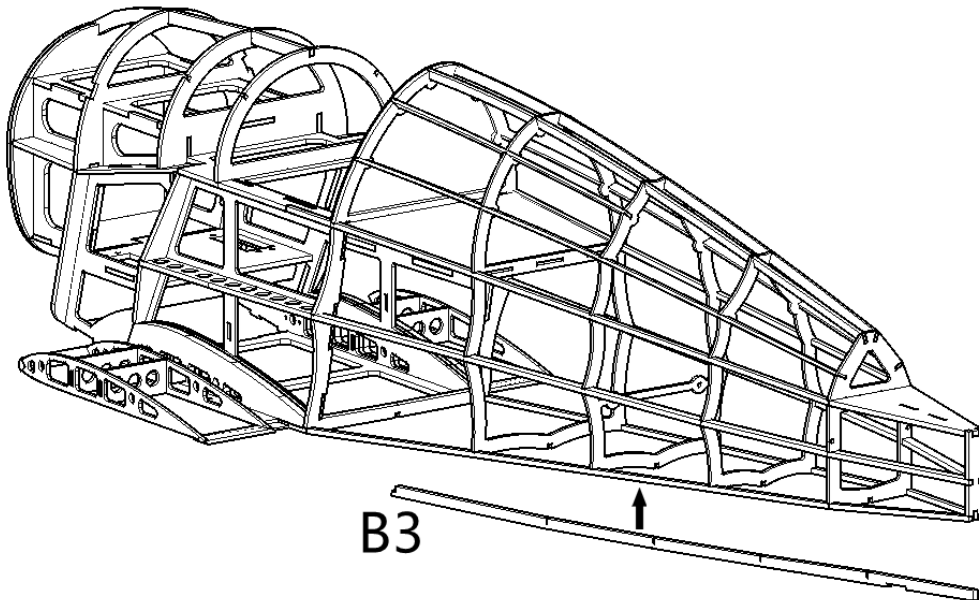

Schritt 47

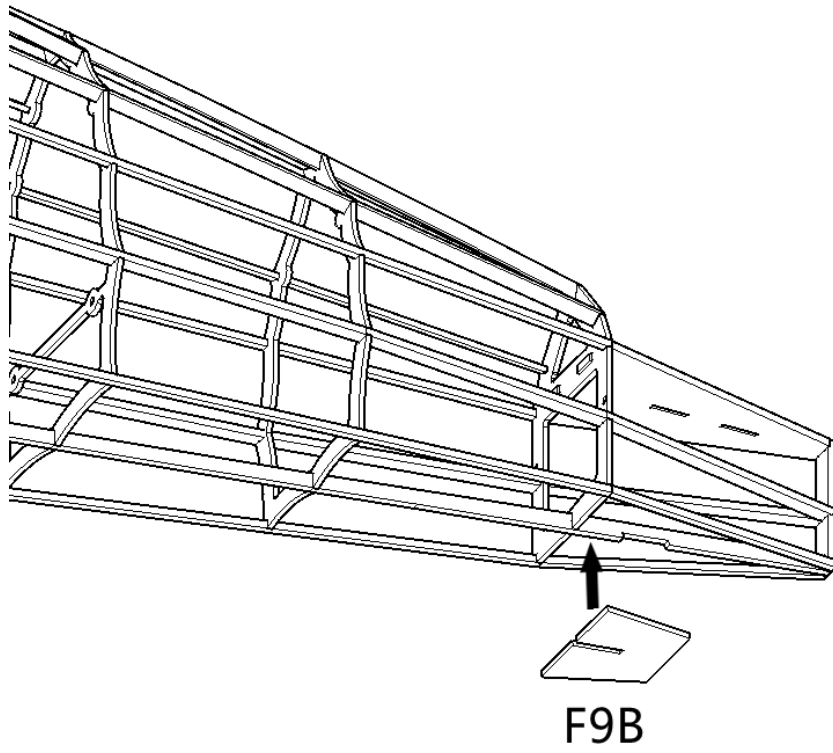

Schritt 48

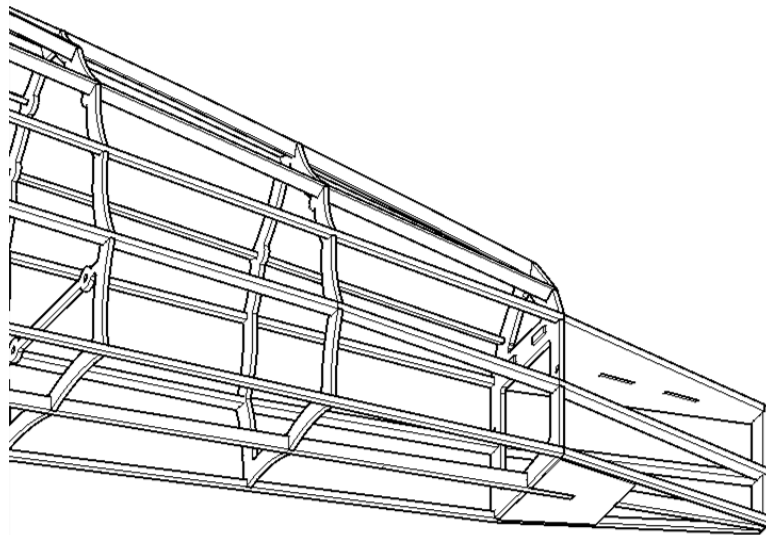

Schritt 49

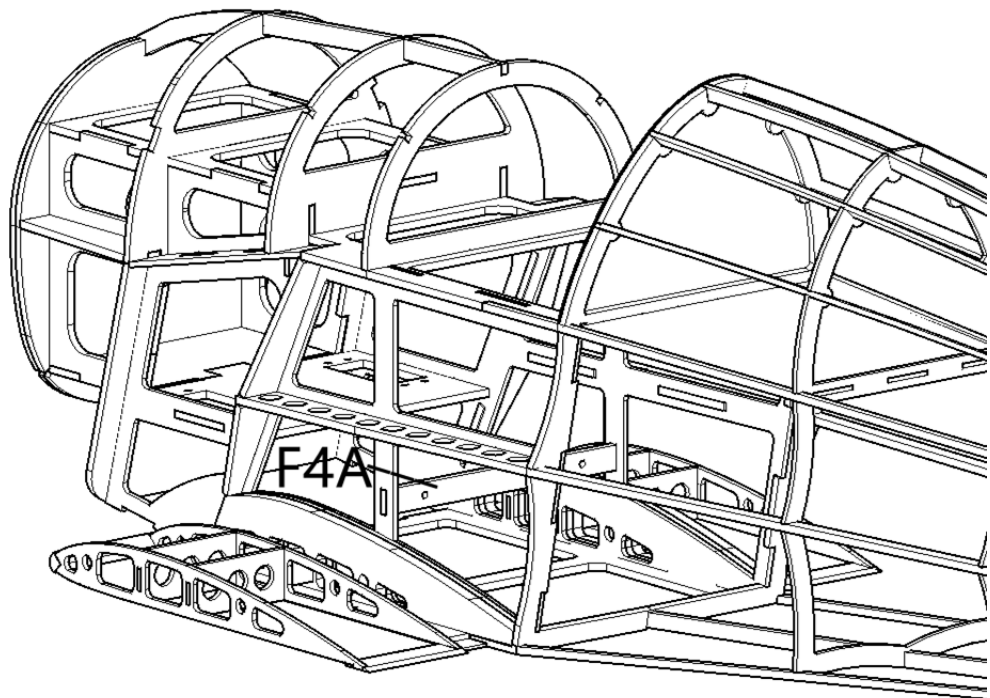

Schritt 50: 3 x 3 mm Kiefernleisten

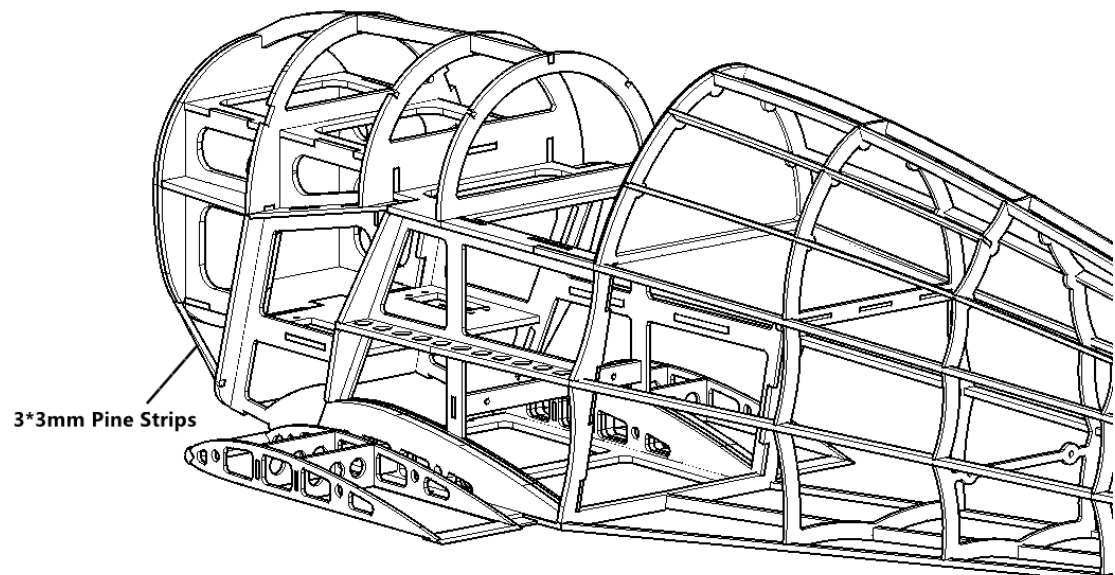

Schritt 51

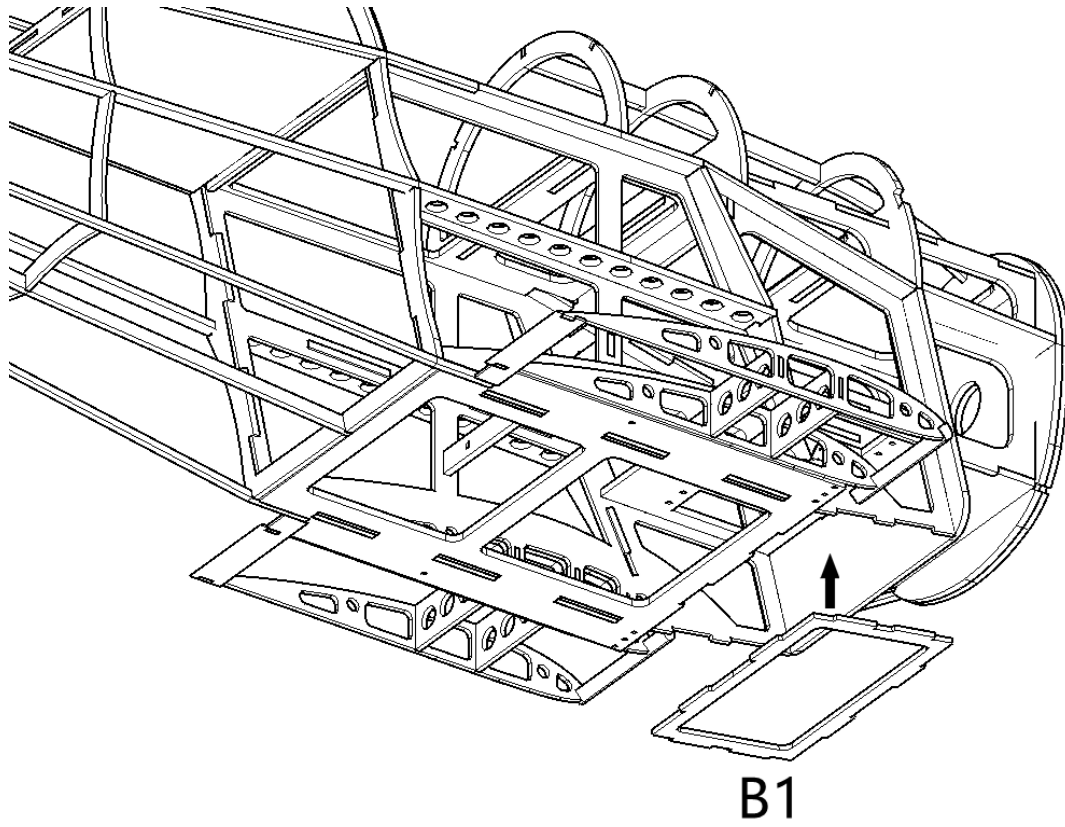

Schritt 52

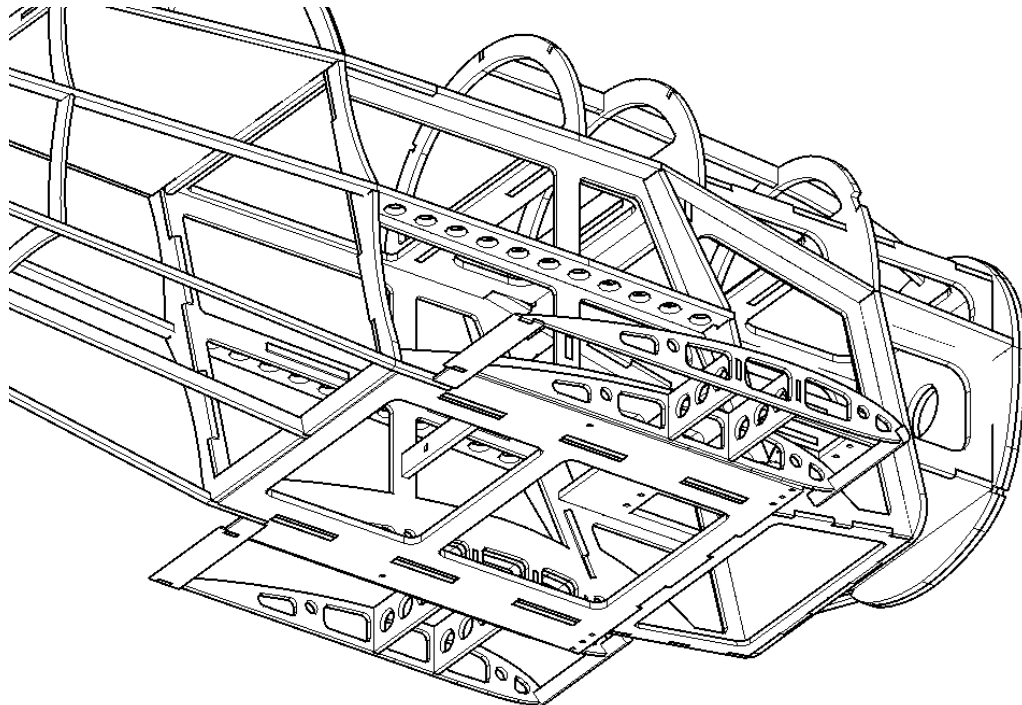

Schritt 53

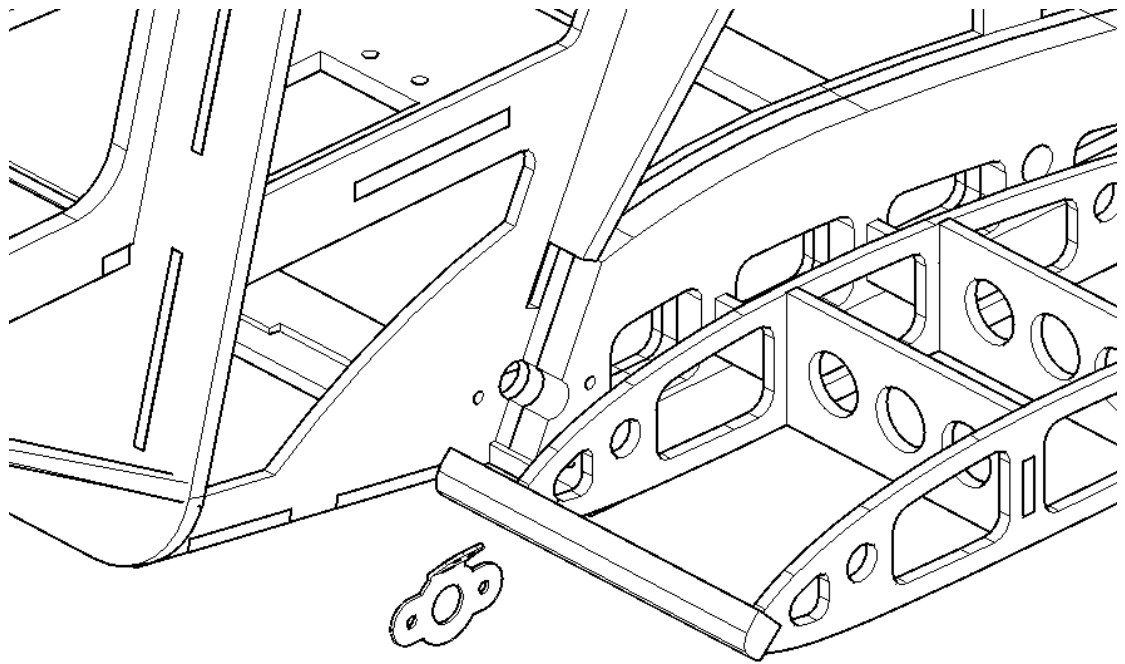

Schritt 54

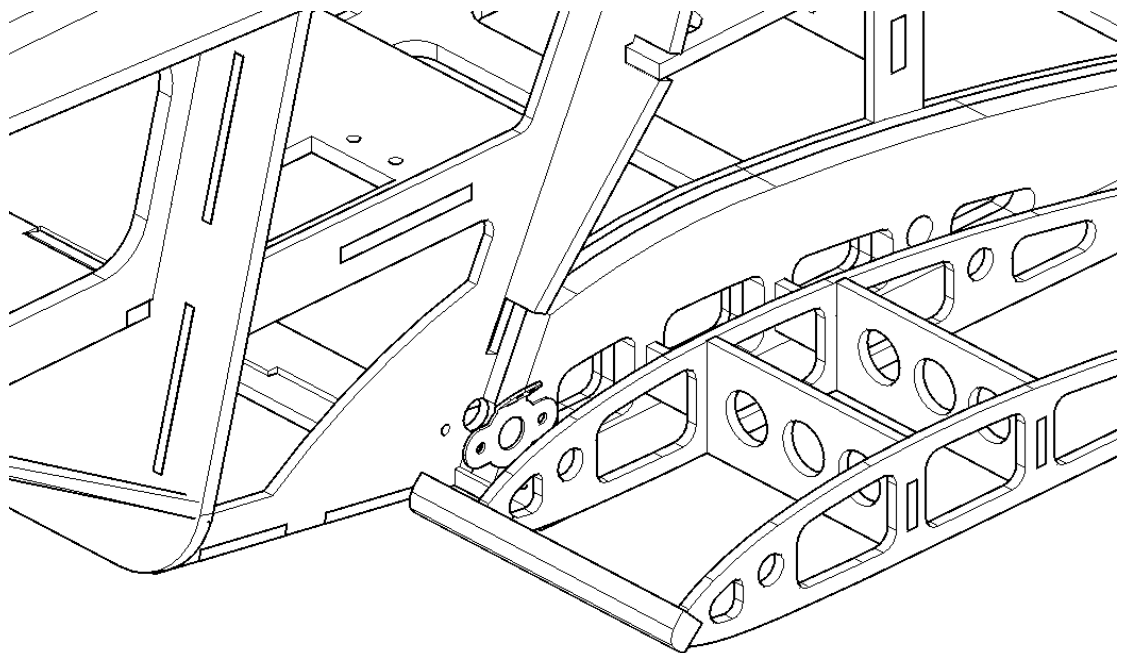

Schritt 55: Aluminiumröhrchen (Außen: 6mm, Innen 4 mm)

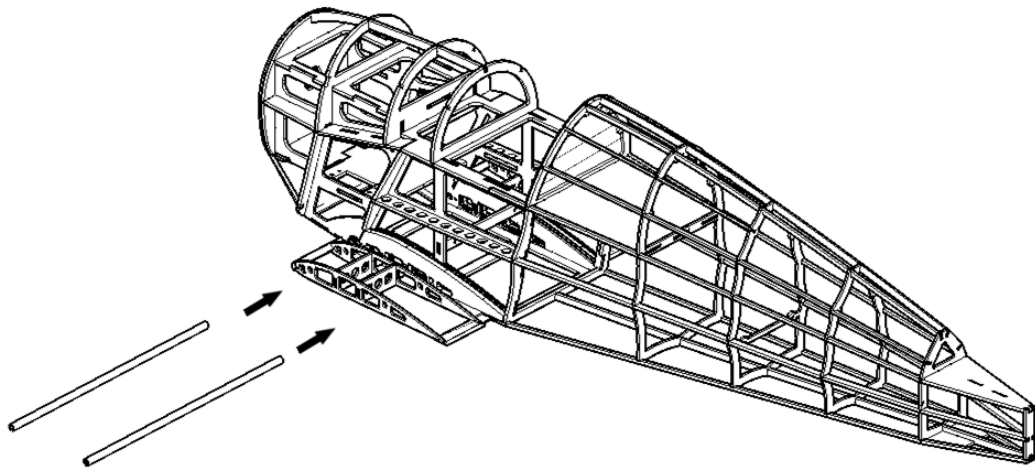

Aluminum Tube
(Outer Φ : 6mm, Inner Φ : 4mm)

Schritt 56

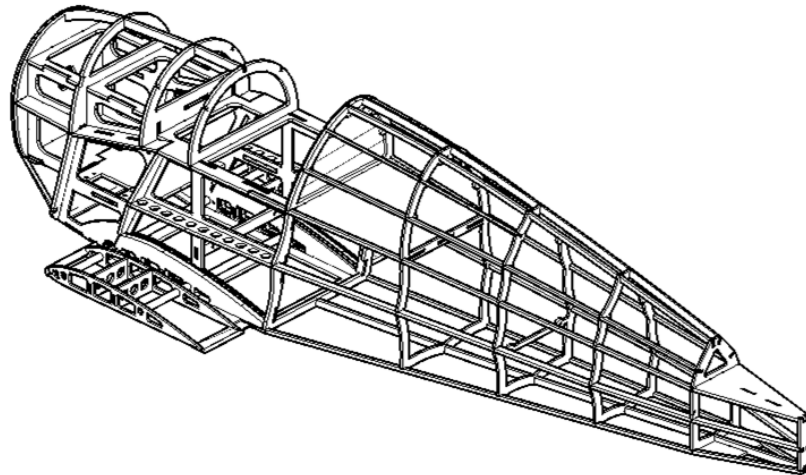

Schritt 57: PVC-Röhrchen (Außen: 3 mm, Innen: 2 mm)

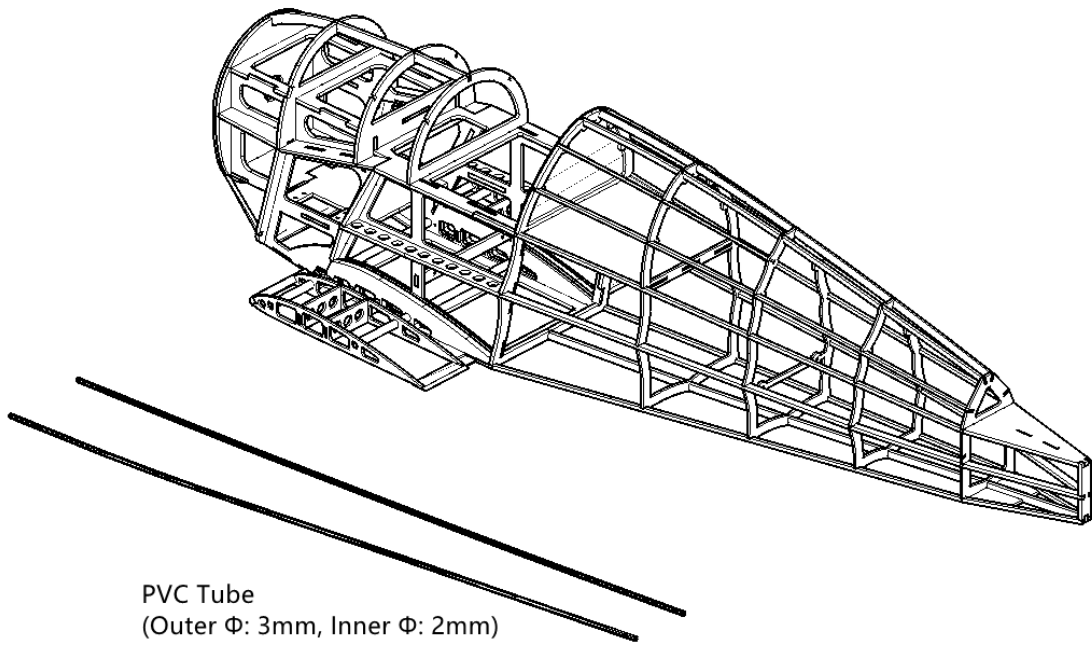

Schritt 58

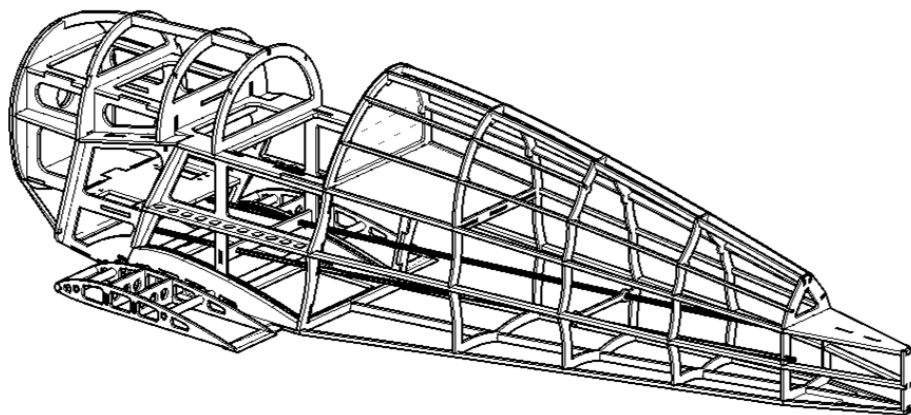

Schritt 59

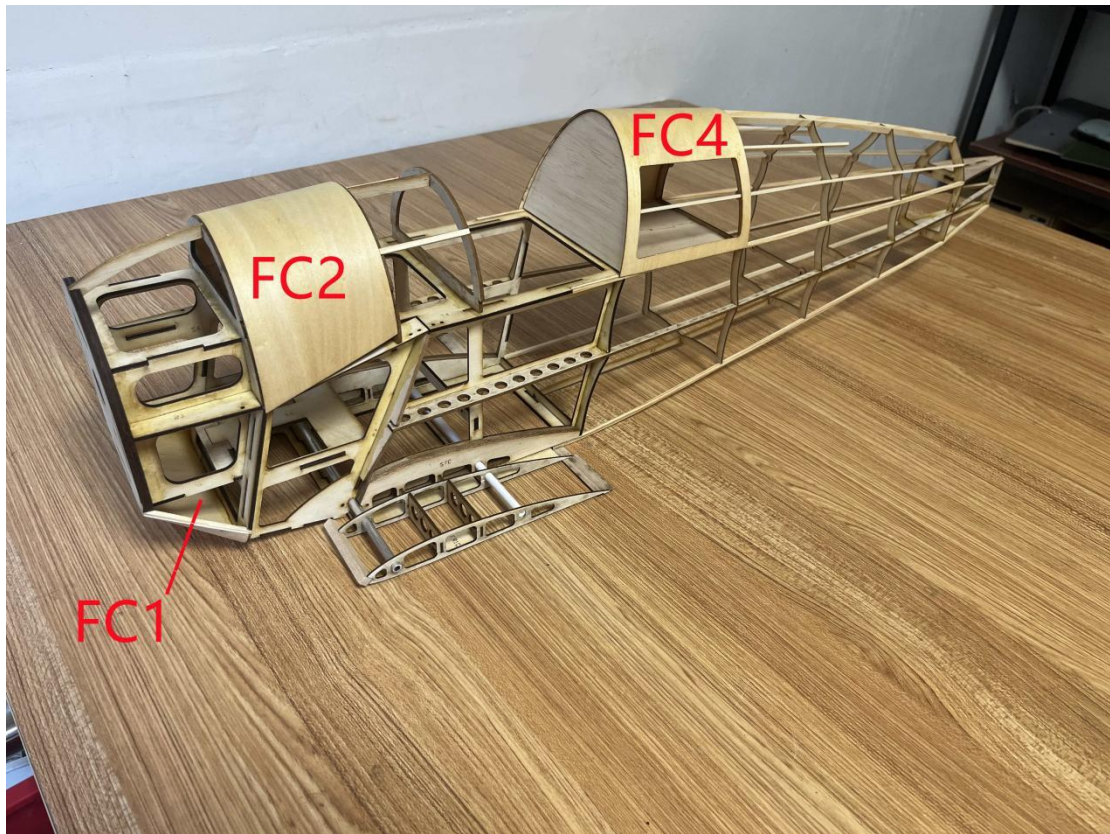

Schritt 60

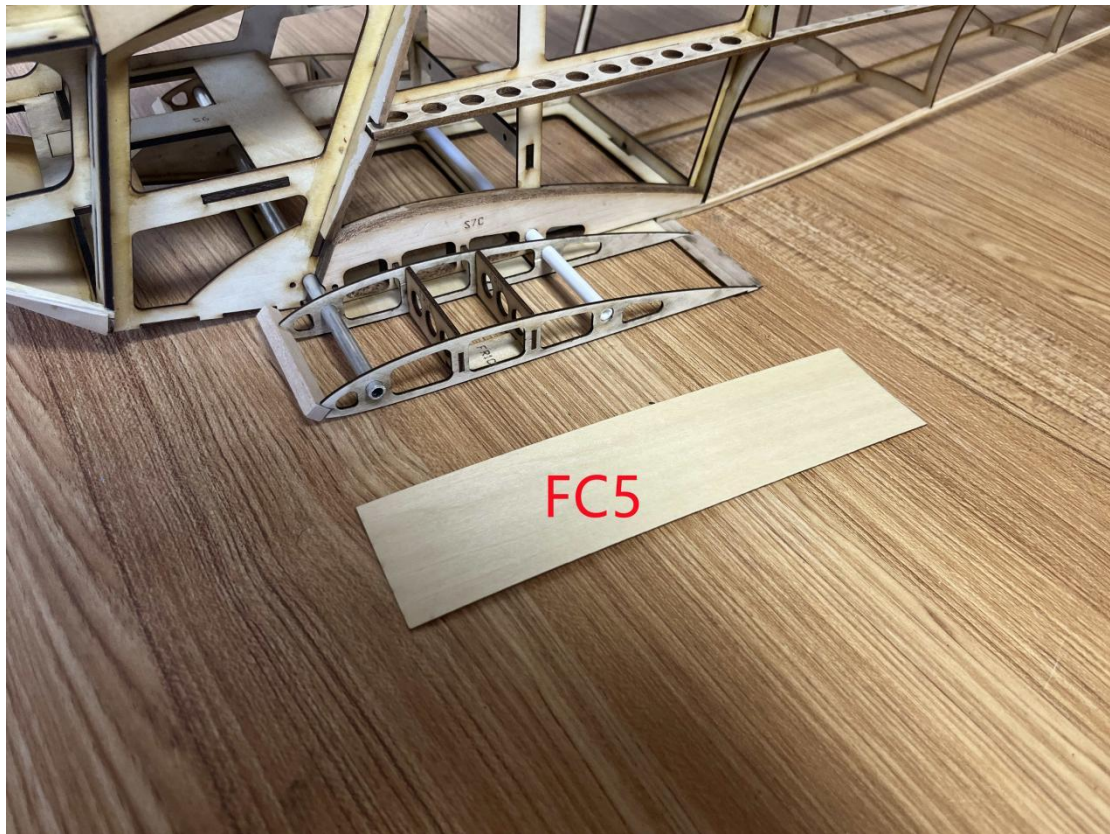

Schritt 61

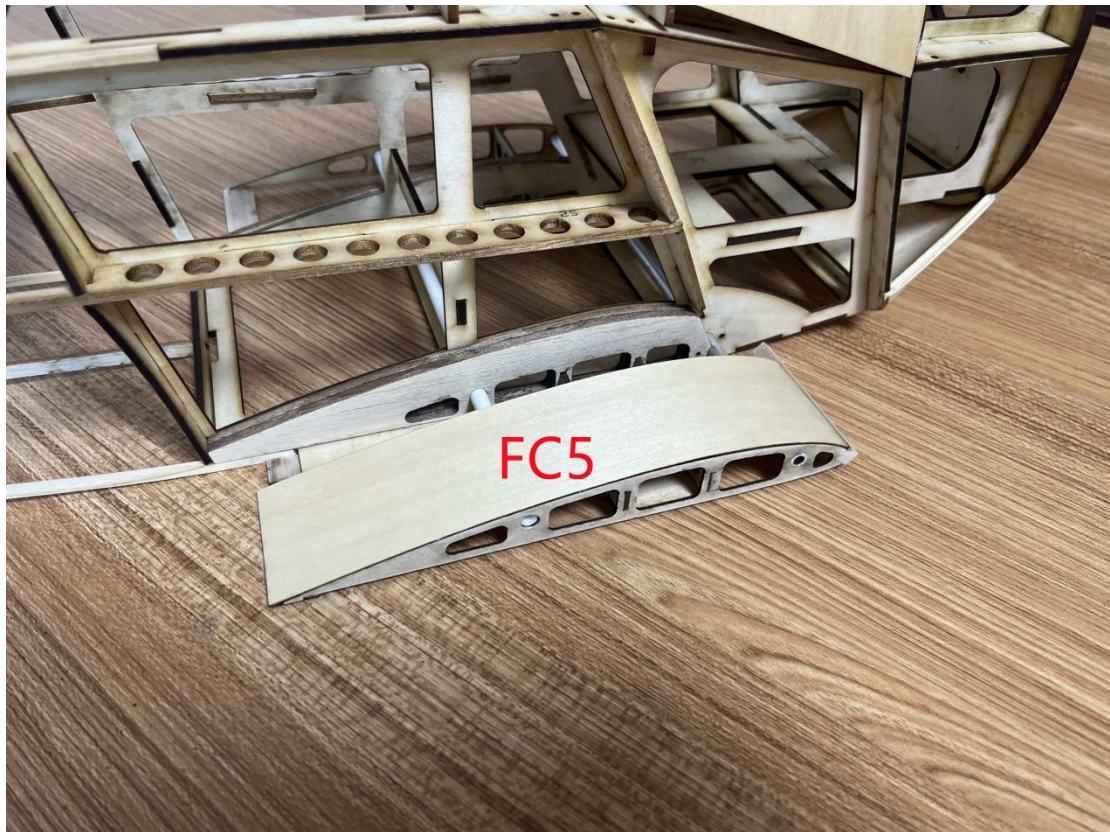

Schritt 62

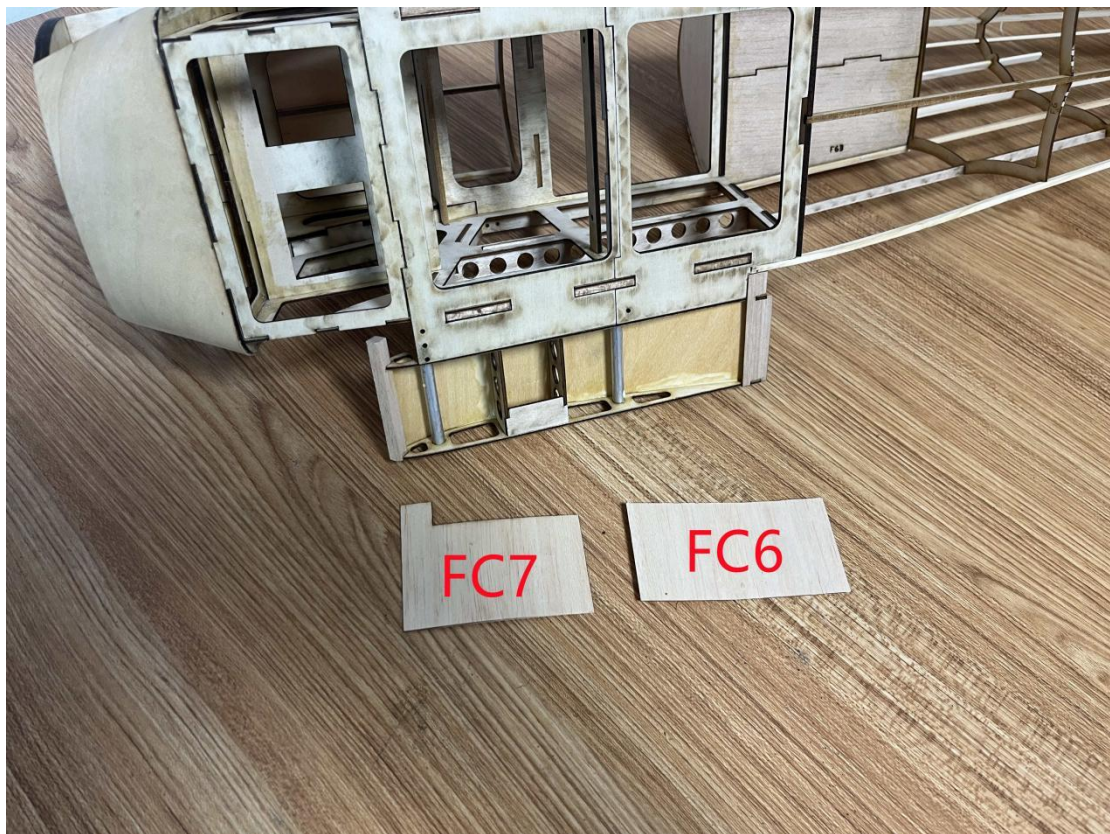

Schritt 63

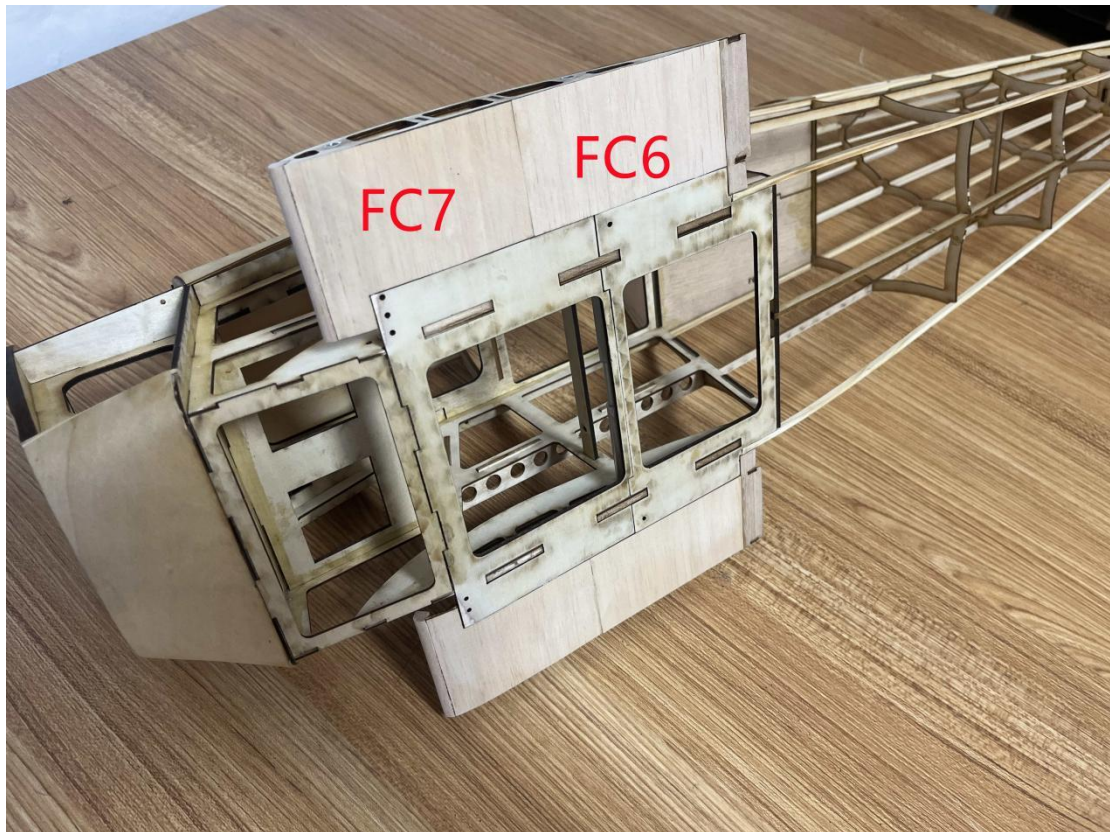

Schritt 64: 5 mm Schubstangen Auslass

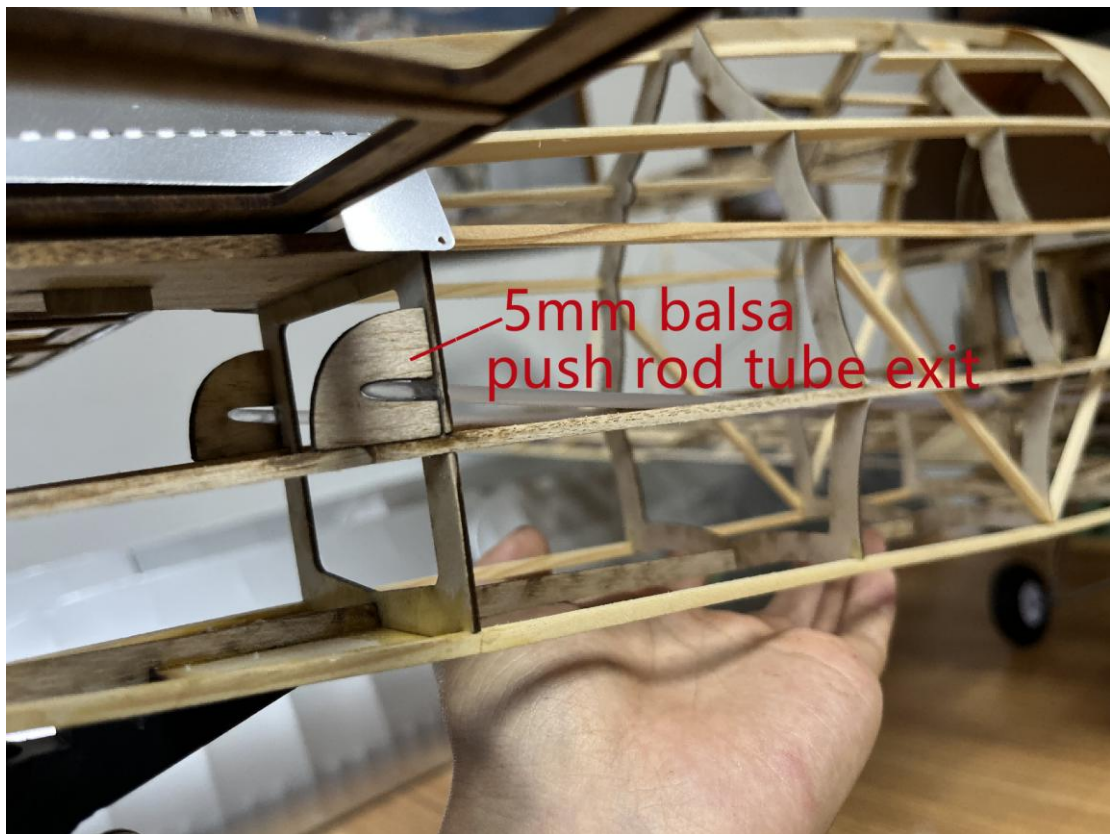

2. Montage - Leitwerk

Schritt

1

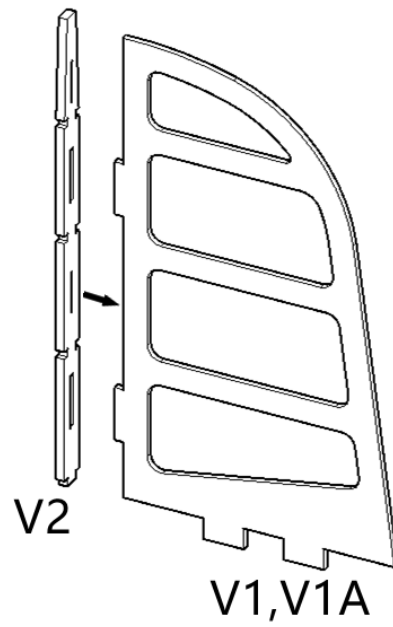

Schritt 2

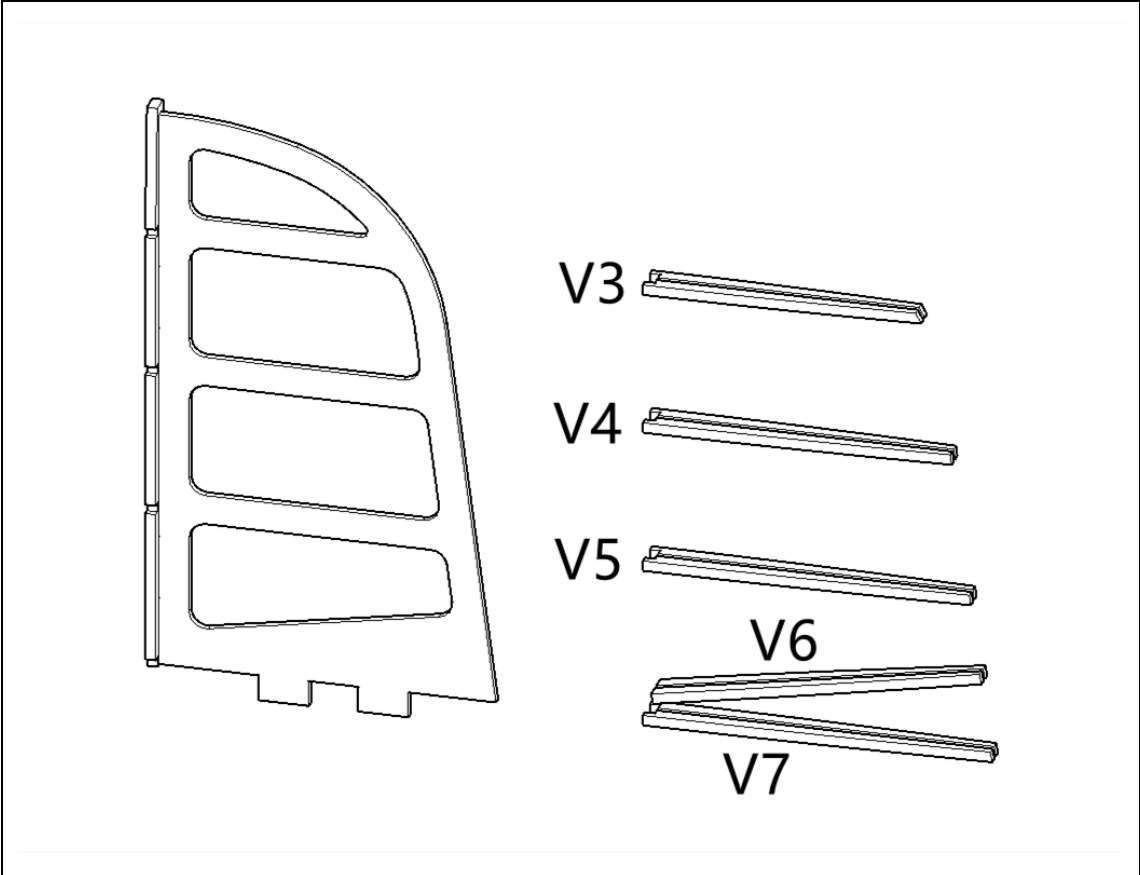

Schritt 3

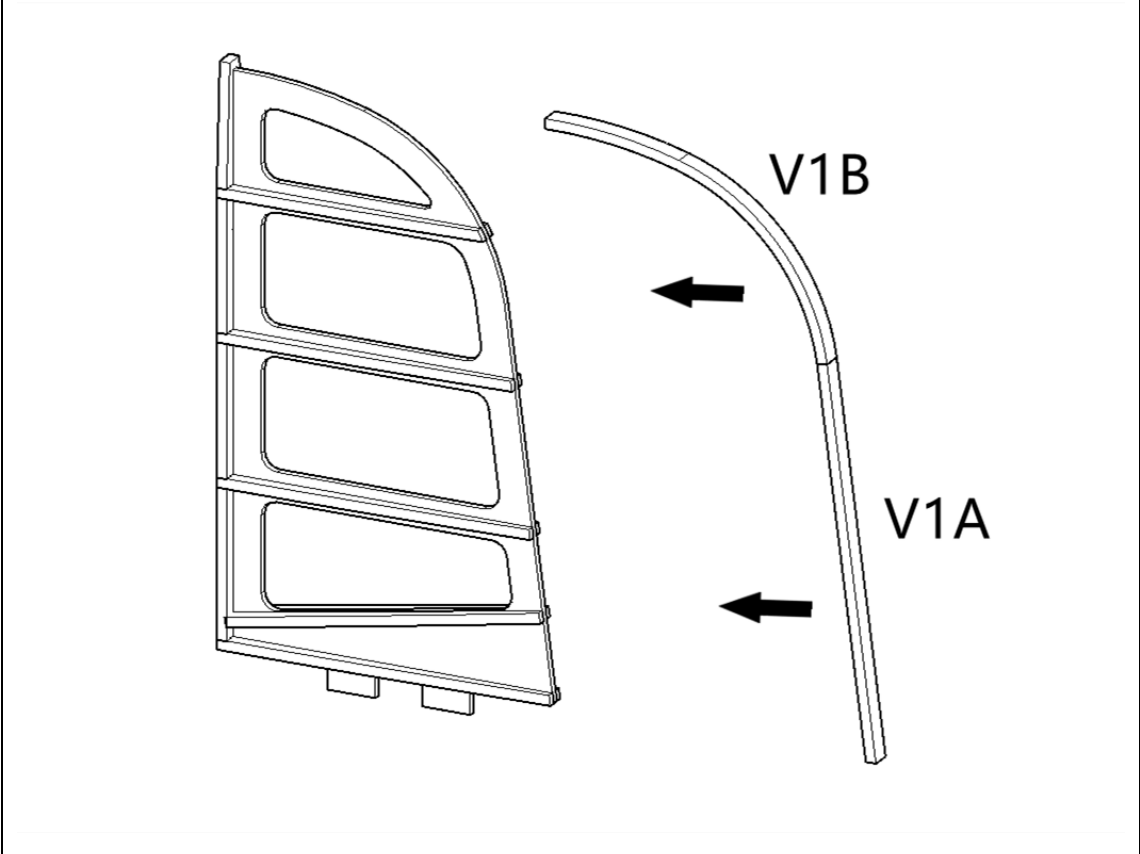

Schritt 4

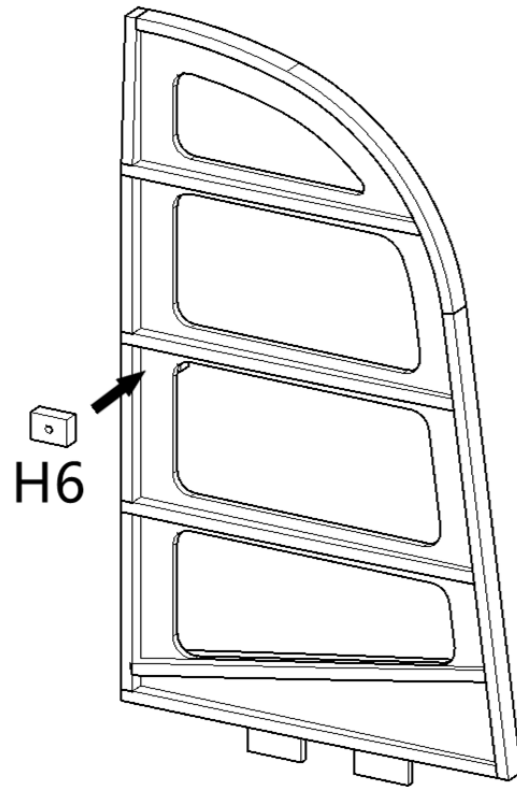

Schritt 5

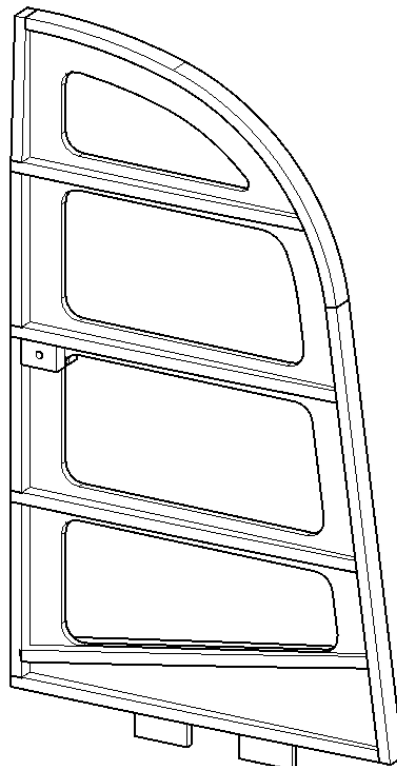

Schritt 6: 2 x 6 mm Kiefernleisten

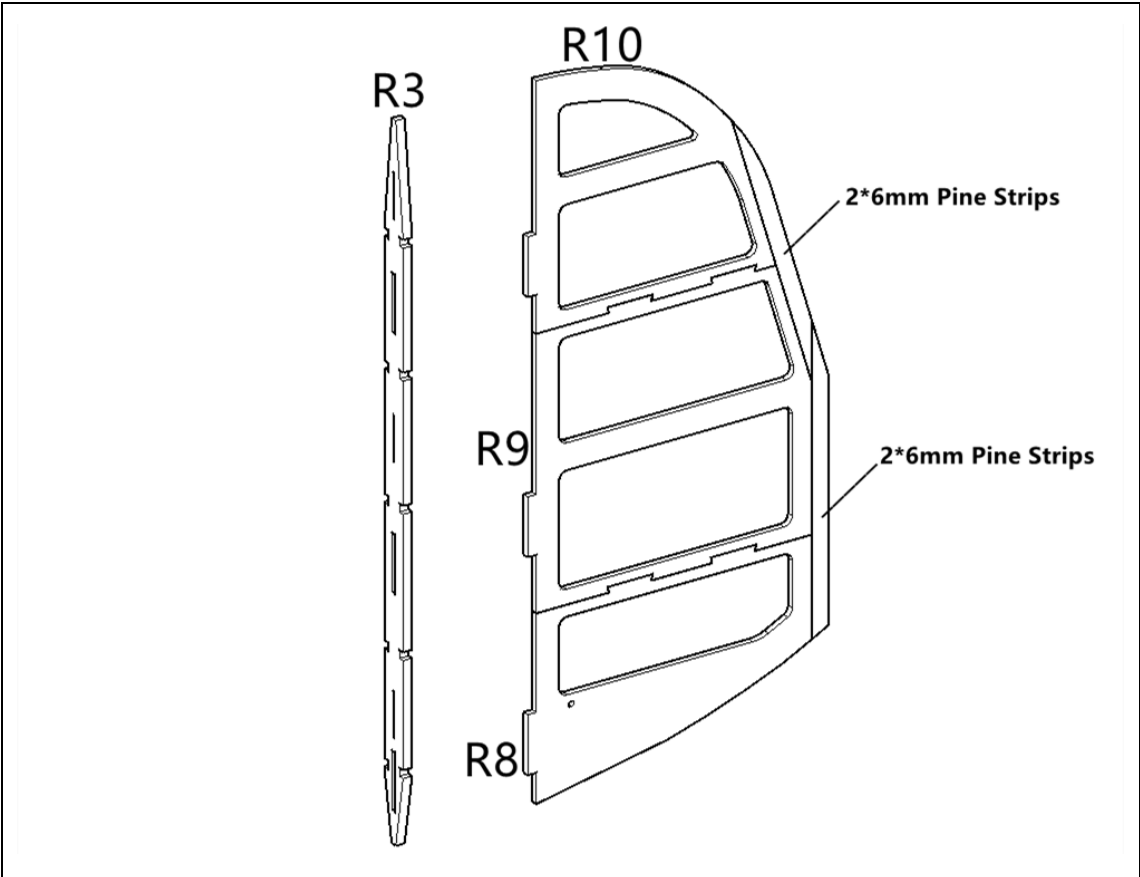

Schritt 7

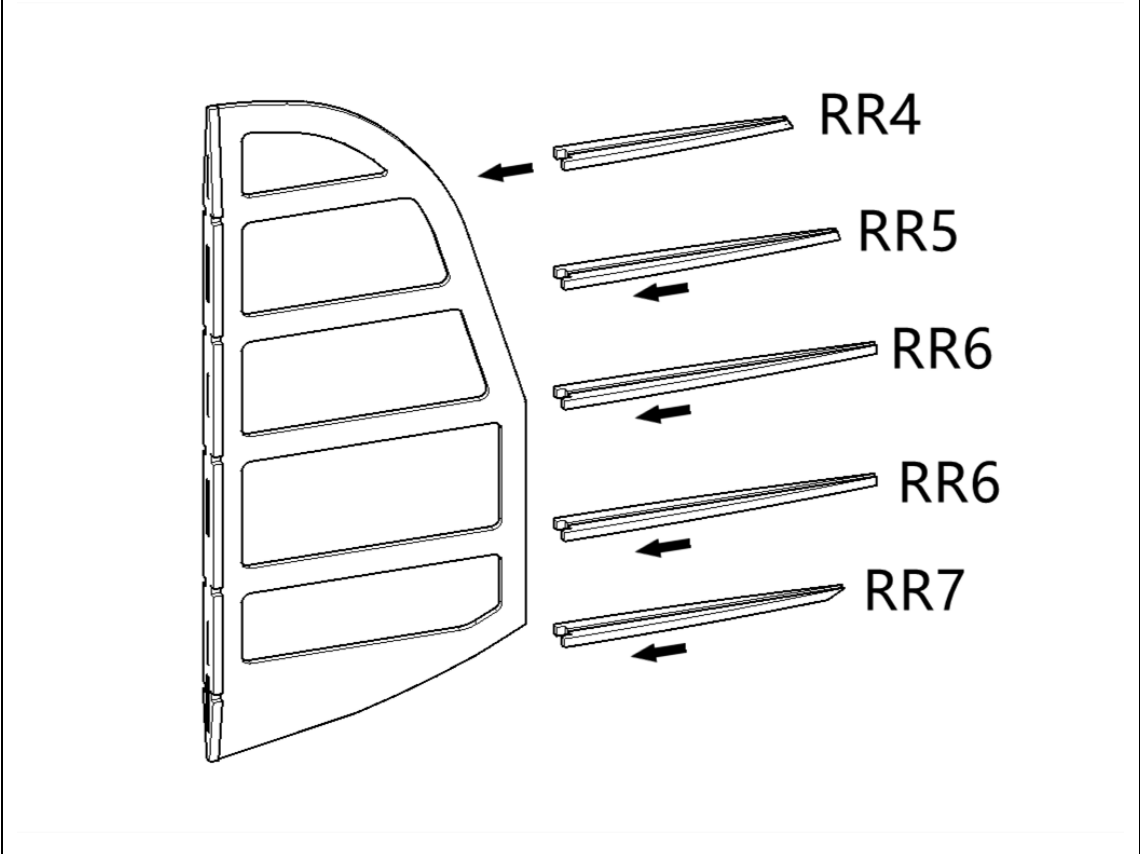

Schritt 8

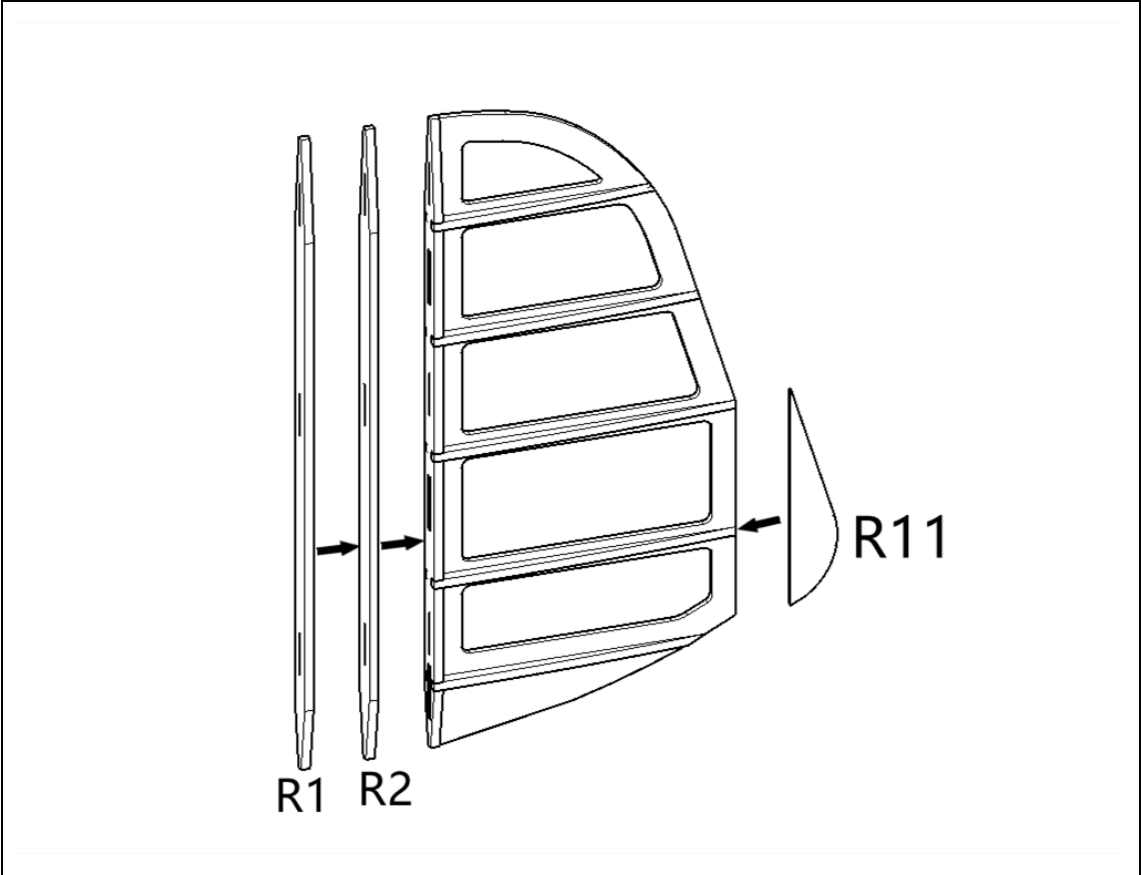

Schritt 9

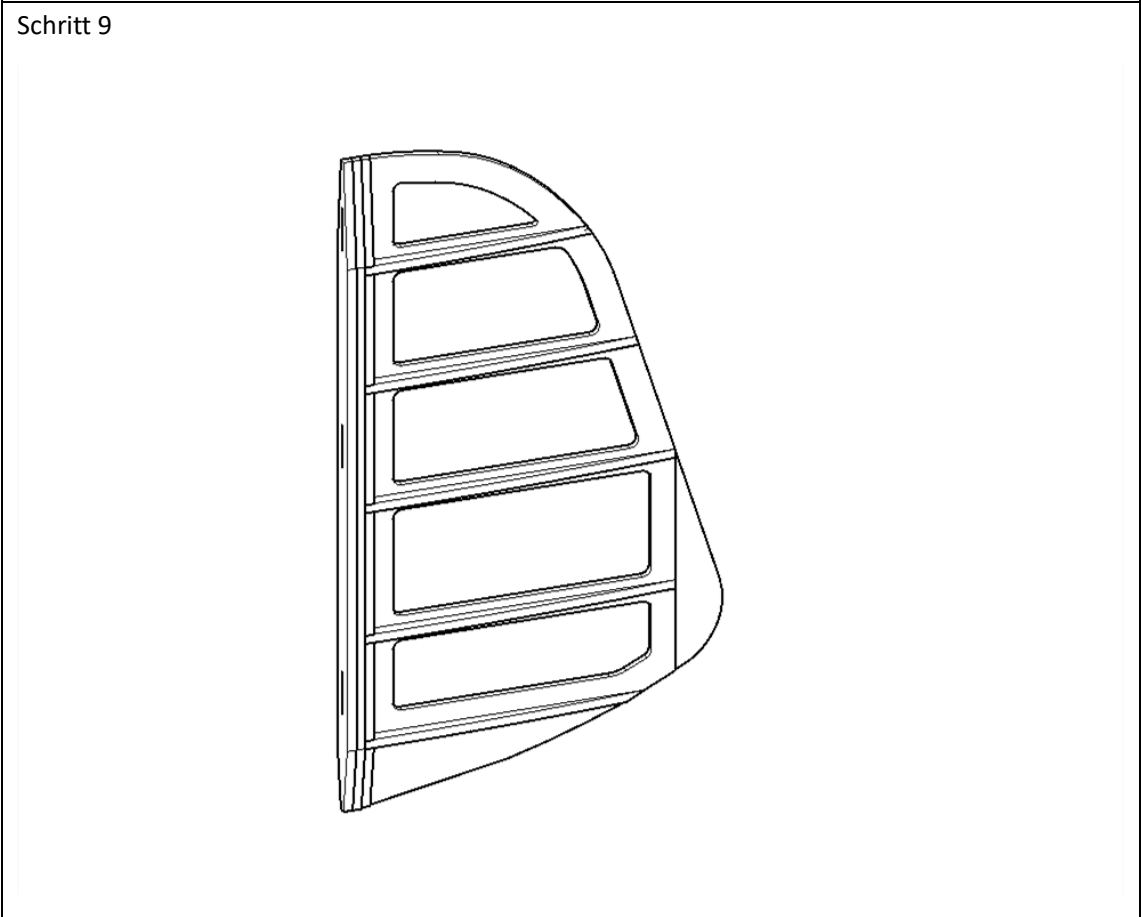

Schritt 10

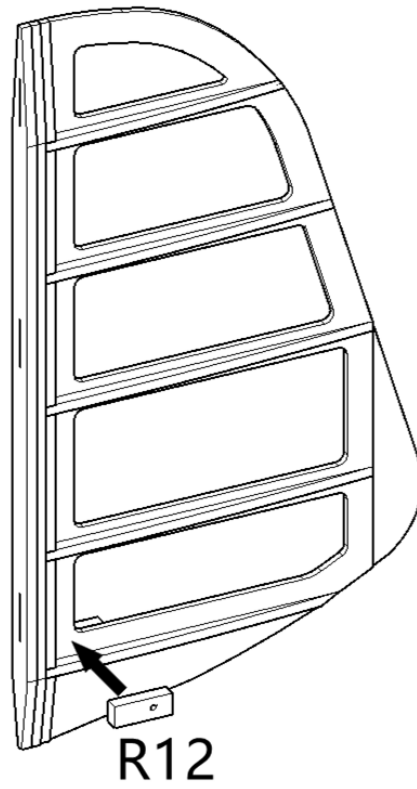

Schritt 11

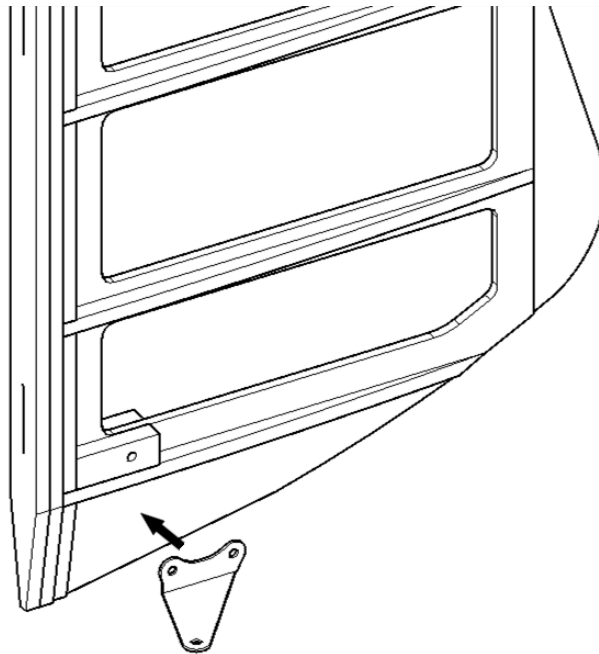

Schritt 12: Bauteil anpassen

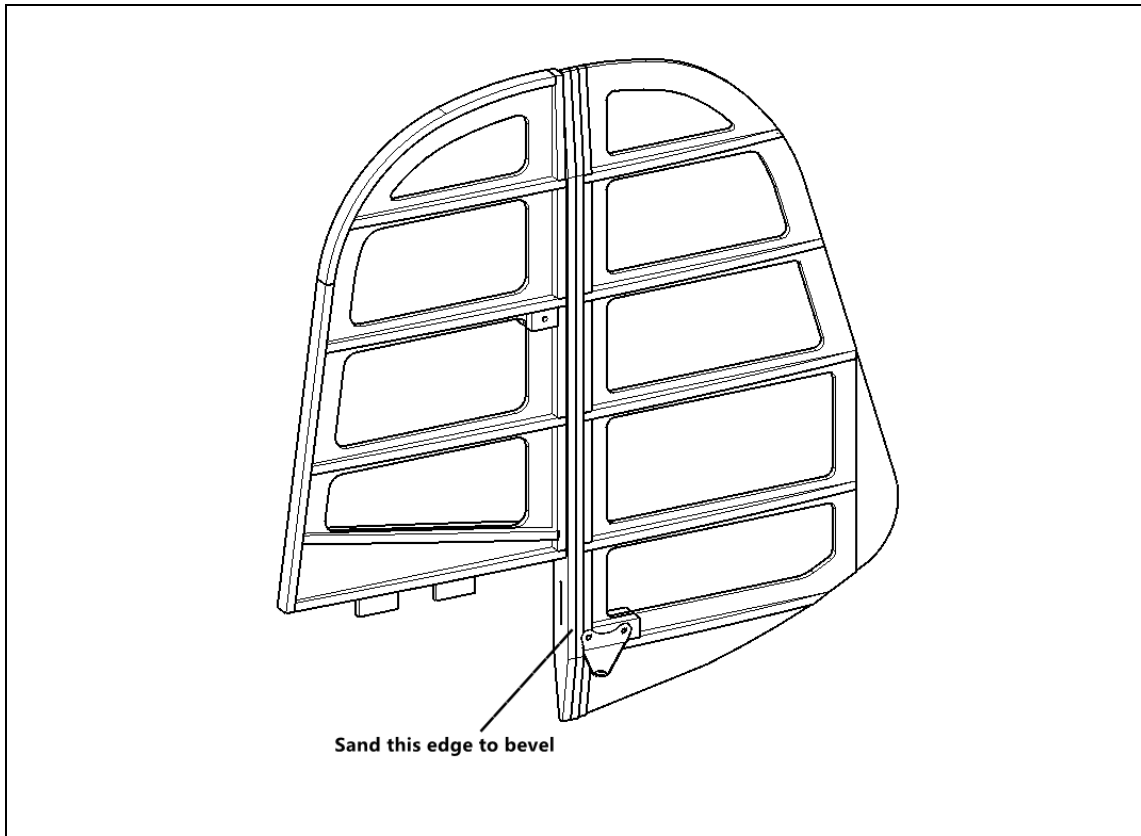

Schritt 13

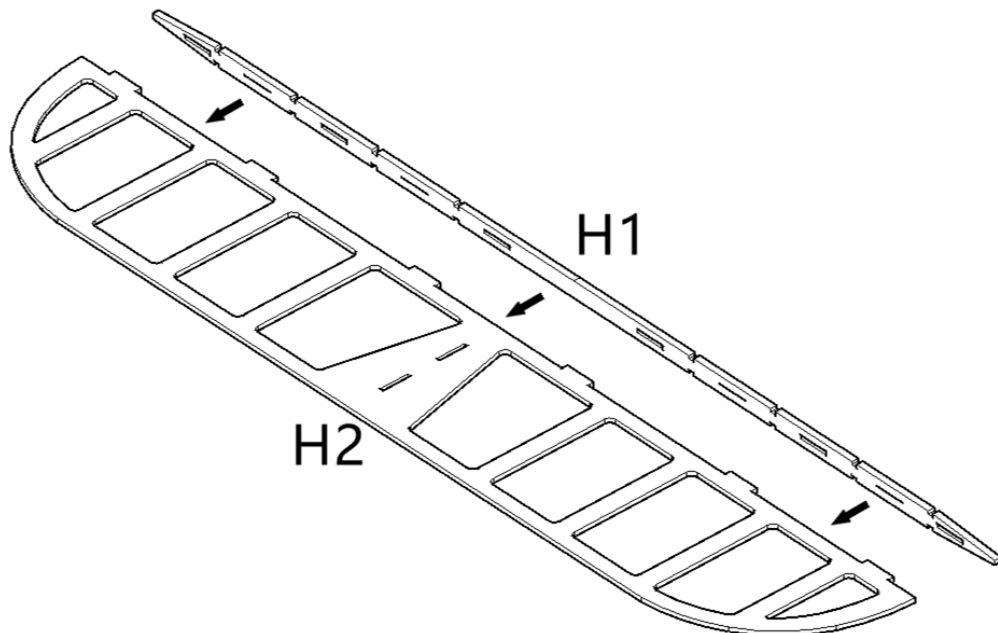

Schritt 14

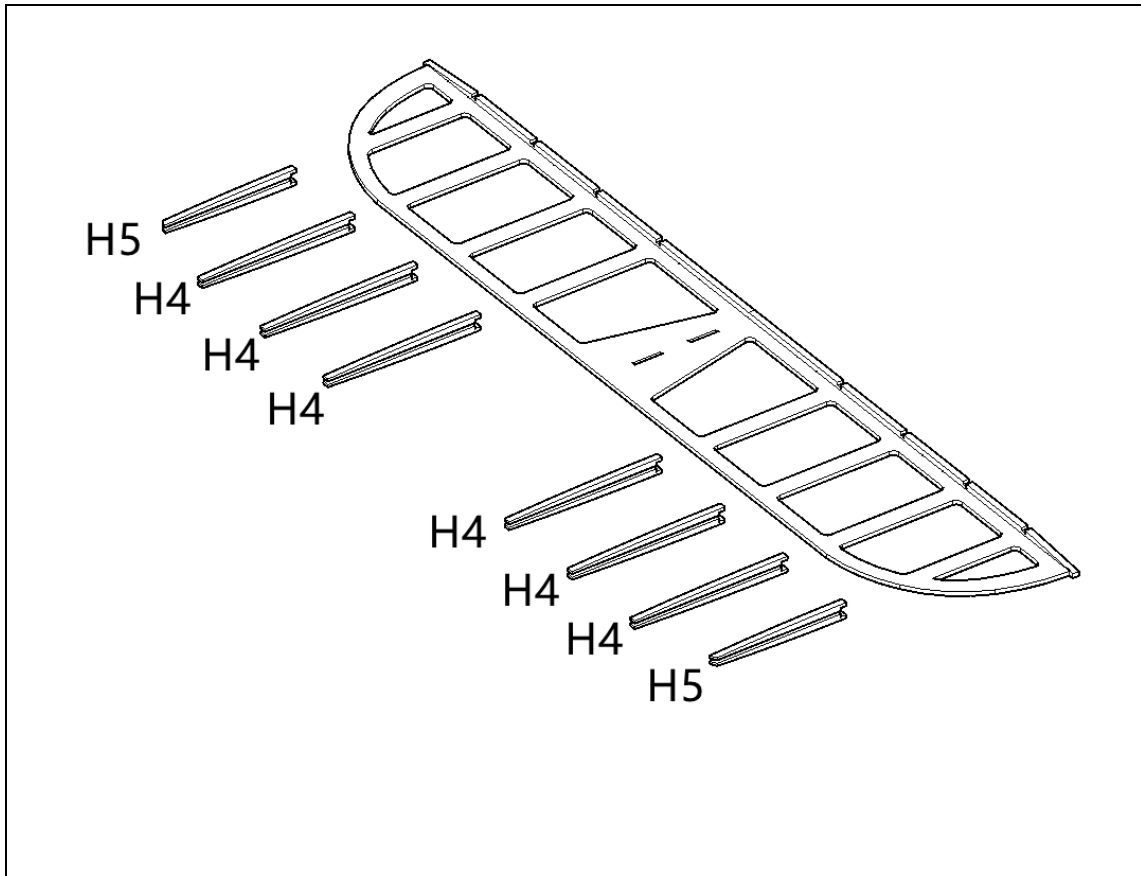

Schritt 15

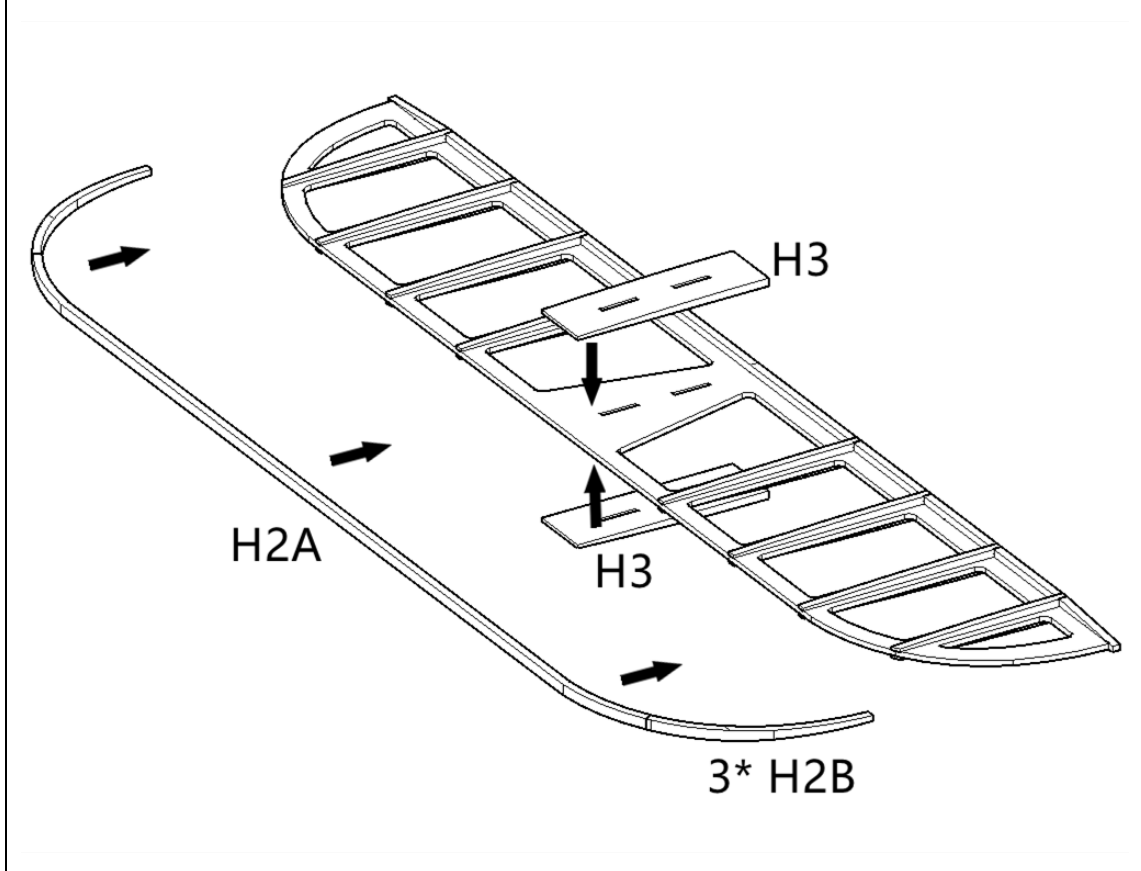

Schritt 16

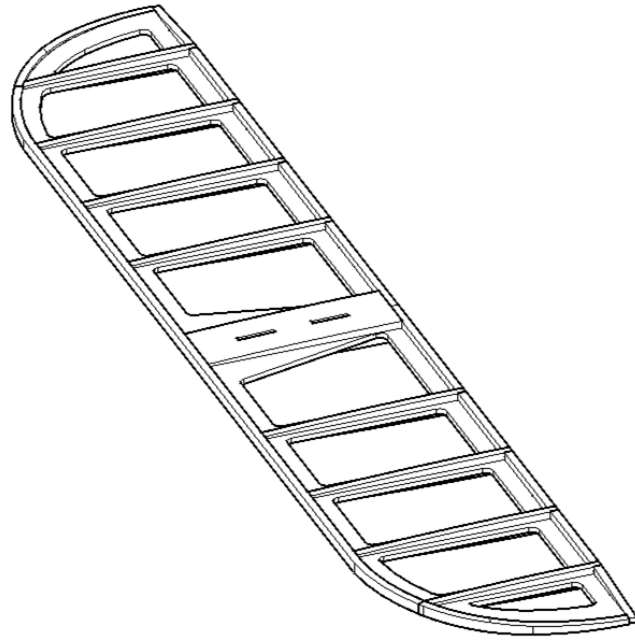

Schritt 17

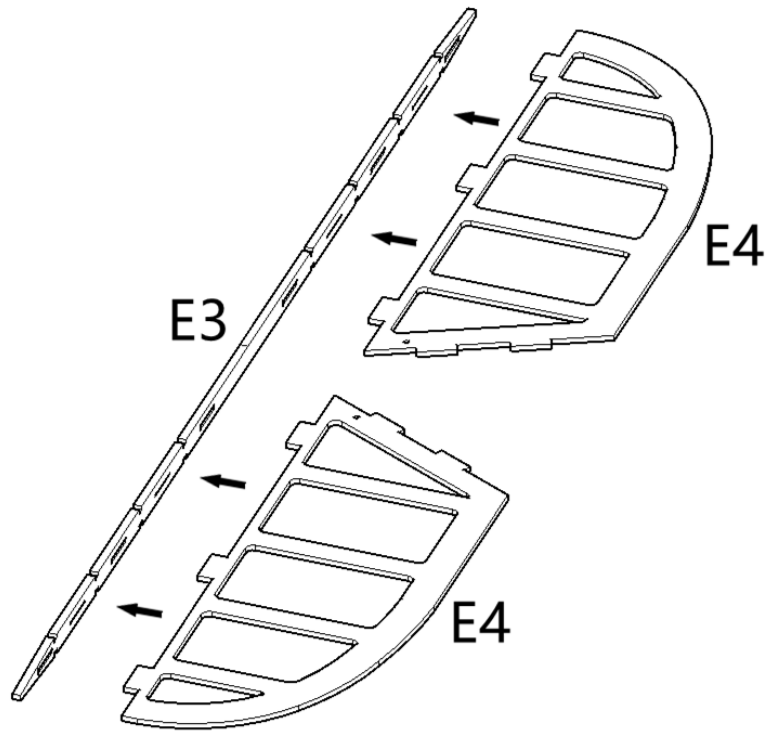

Schritt 18

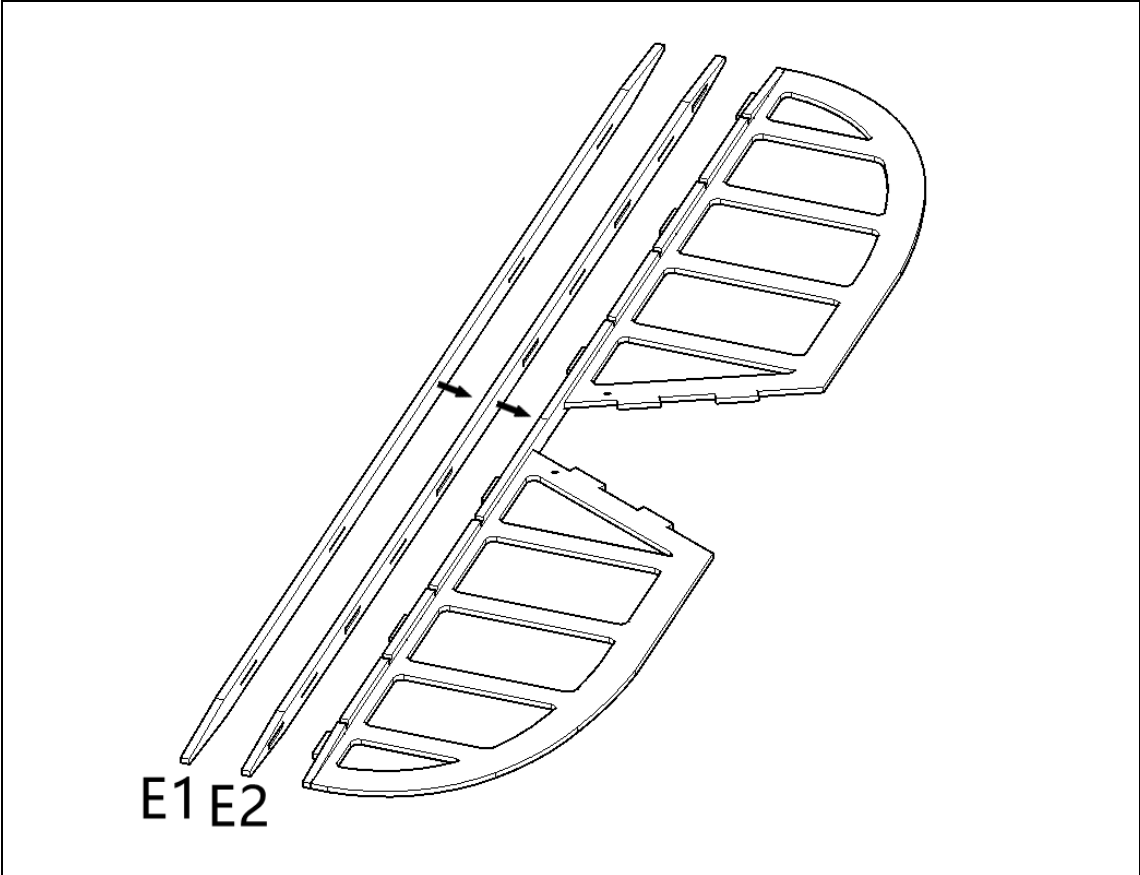

Schritt 19

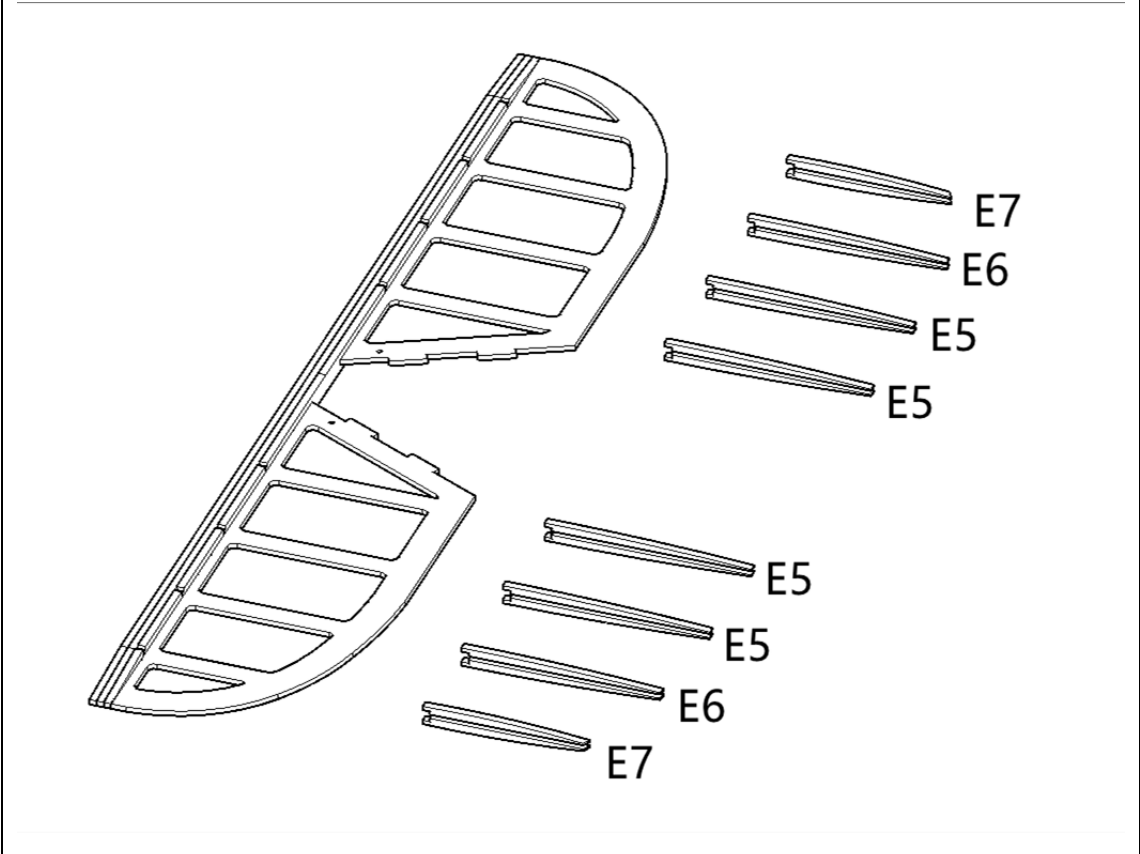

Schritt 20

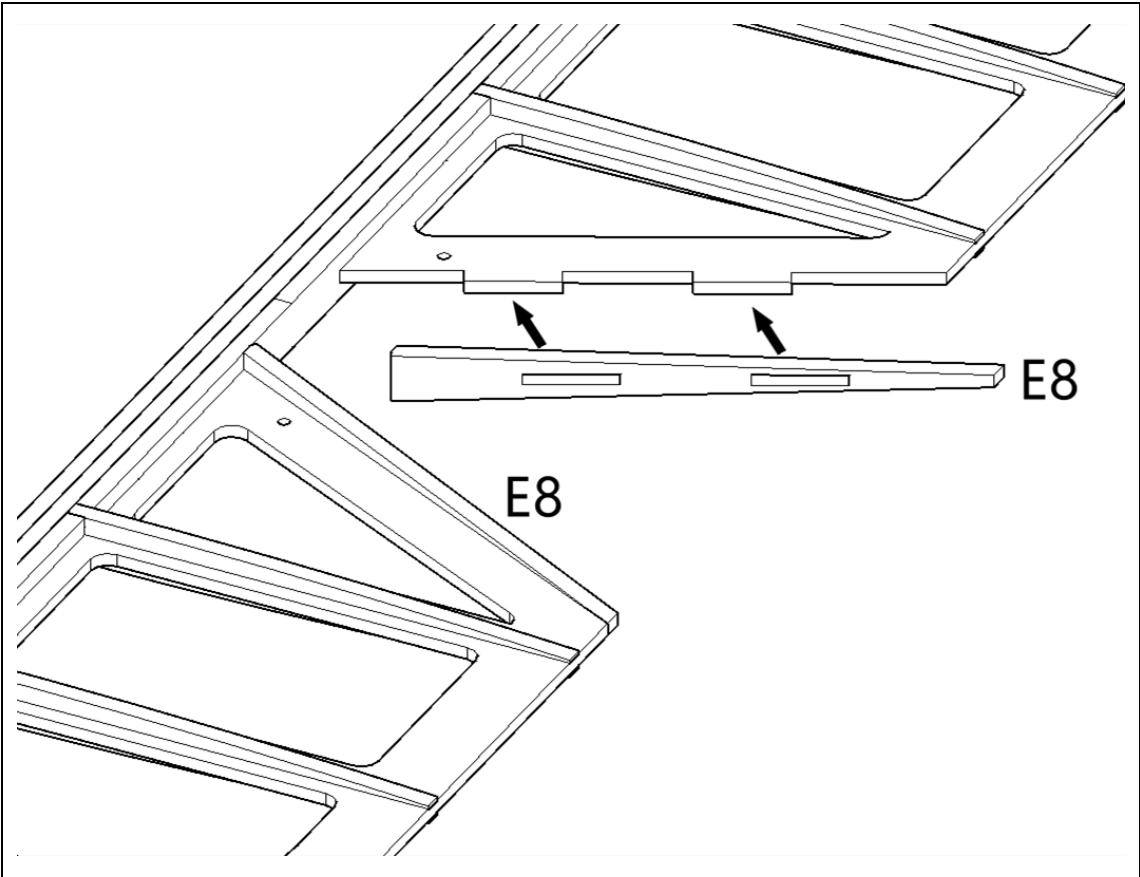

Schritt 21

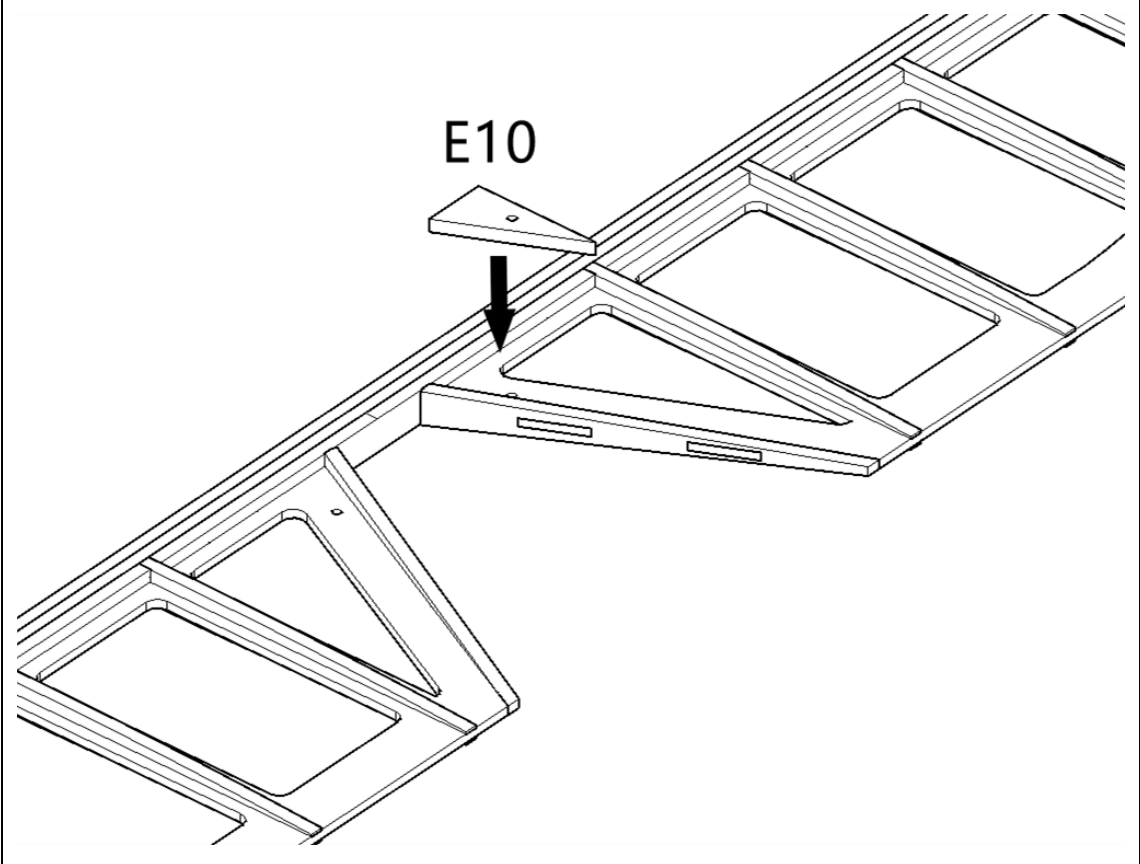

Schritt 22

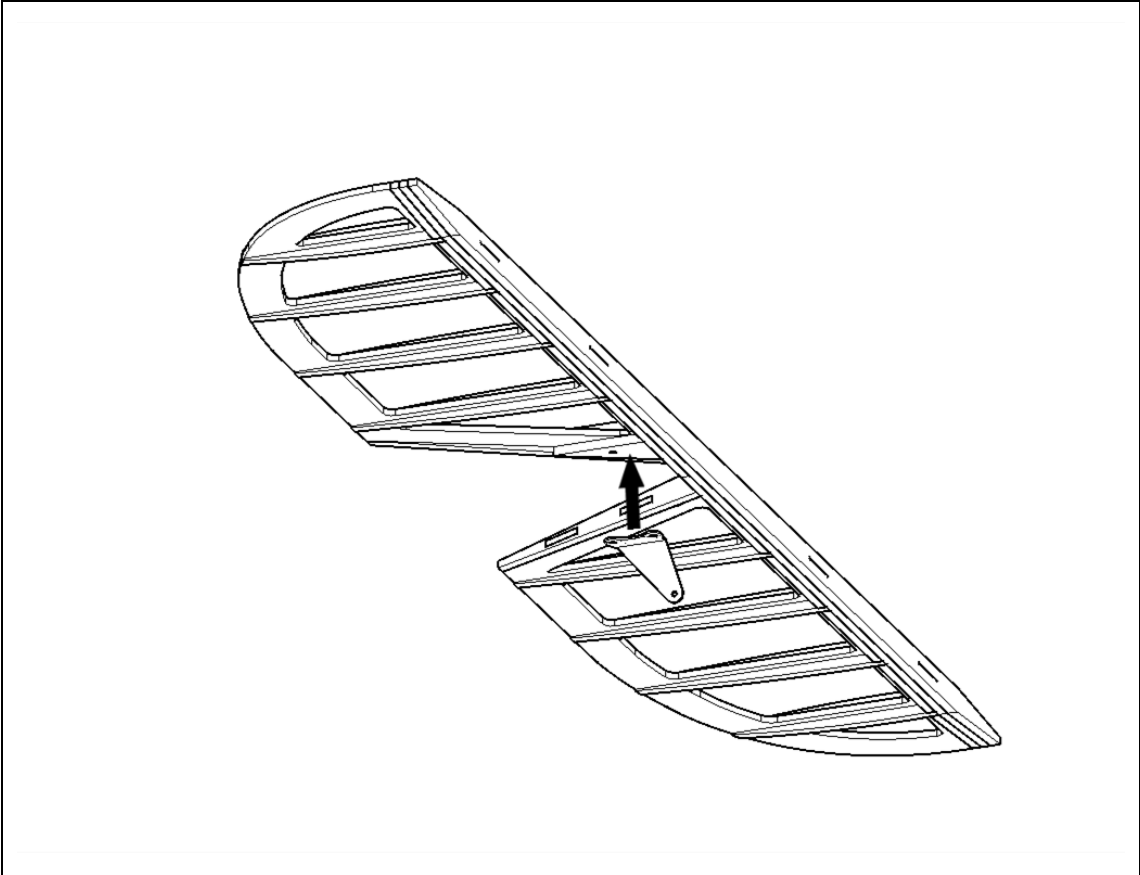

Schritt 23

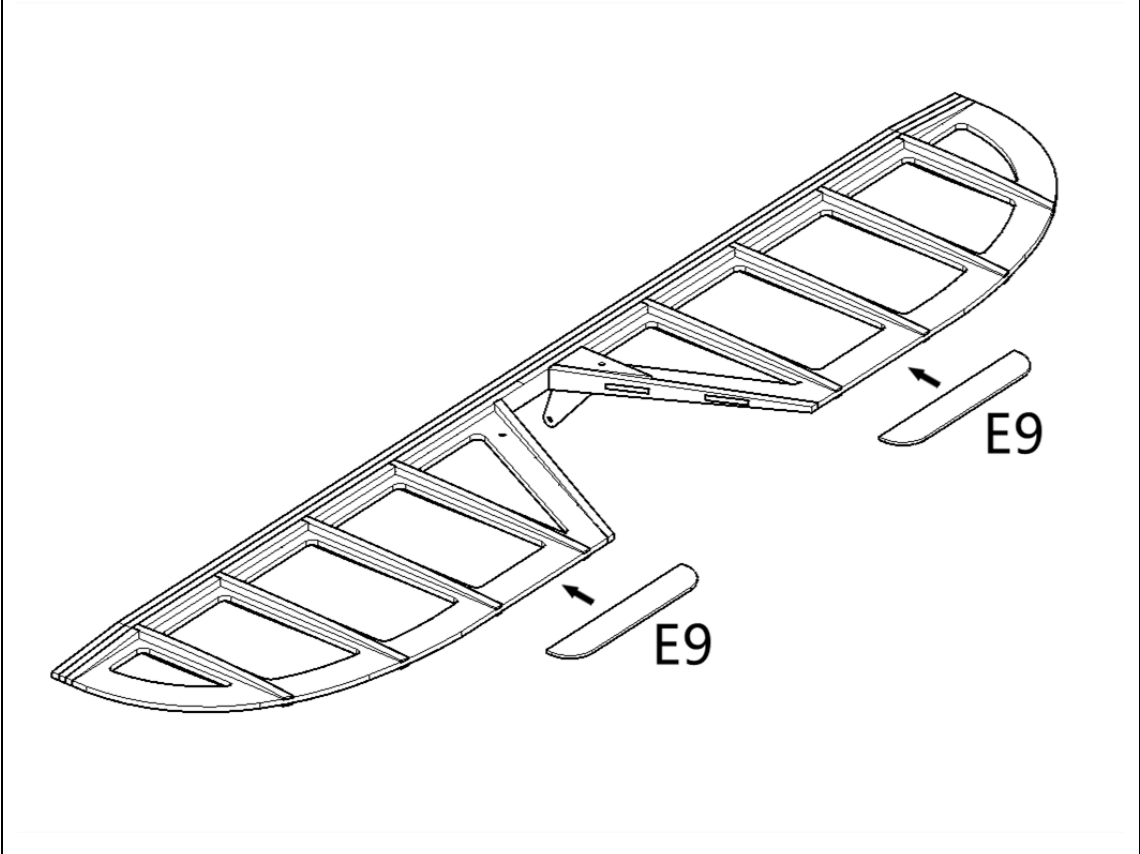

Schritt 24

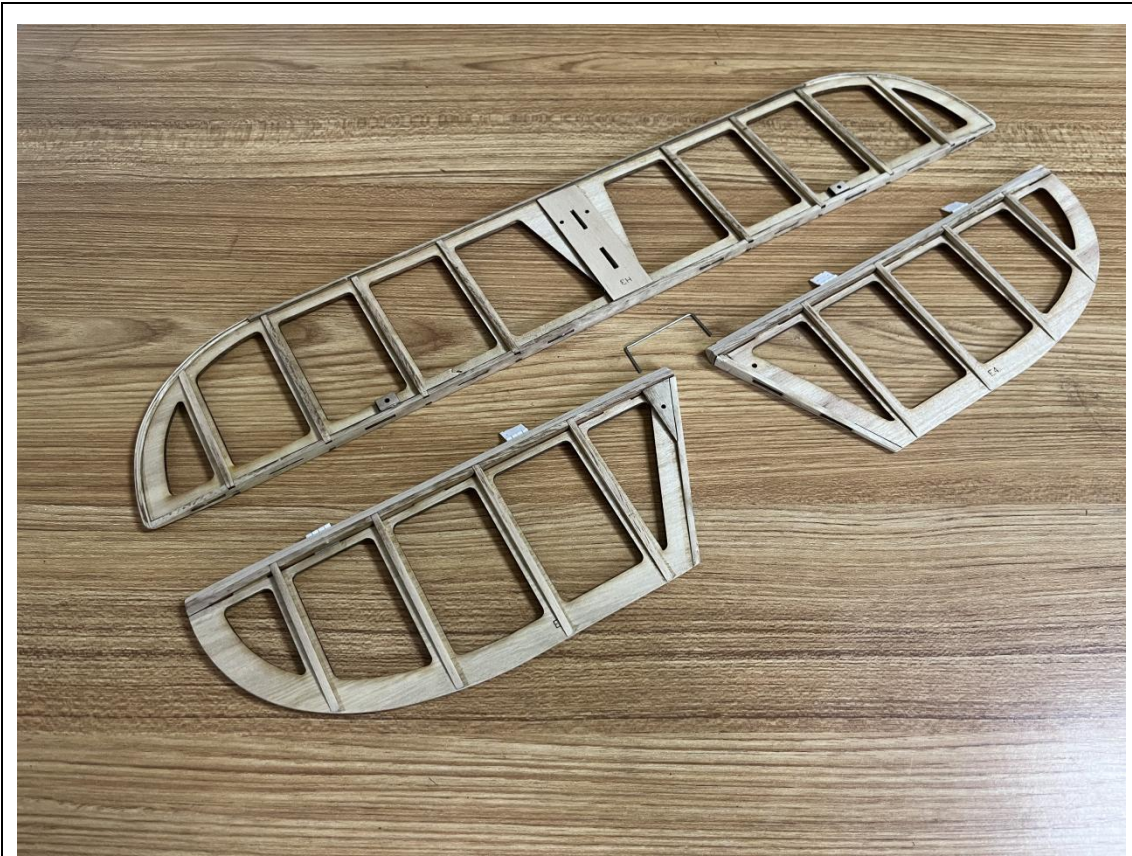

Schritt 25



Schritt 26

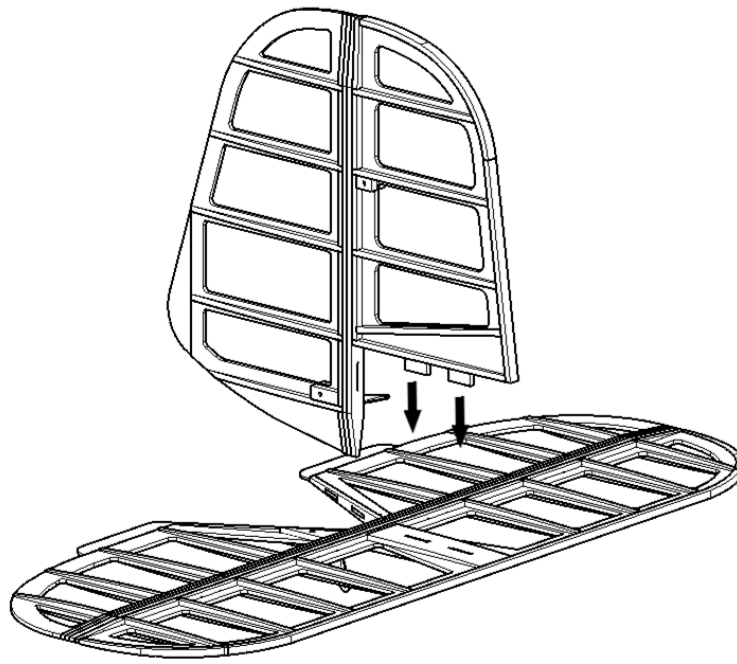

Schritt 27

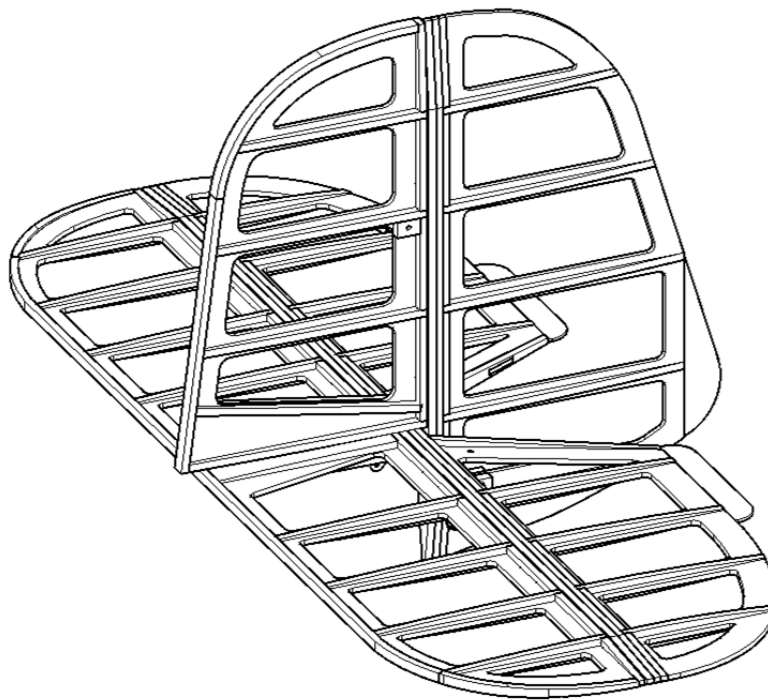

Meine Notizen:

3.Montage - Tragflächen-Mittelteil

Schritt

1

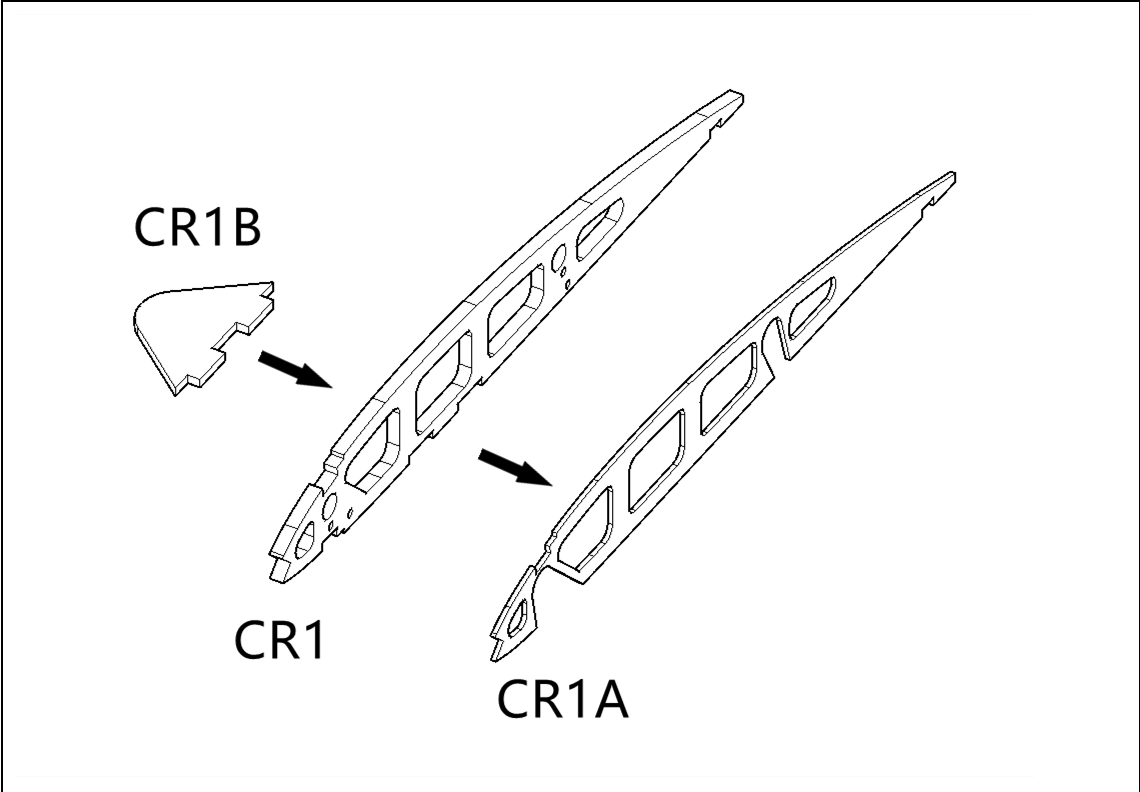

Schritt 2

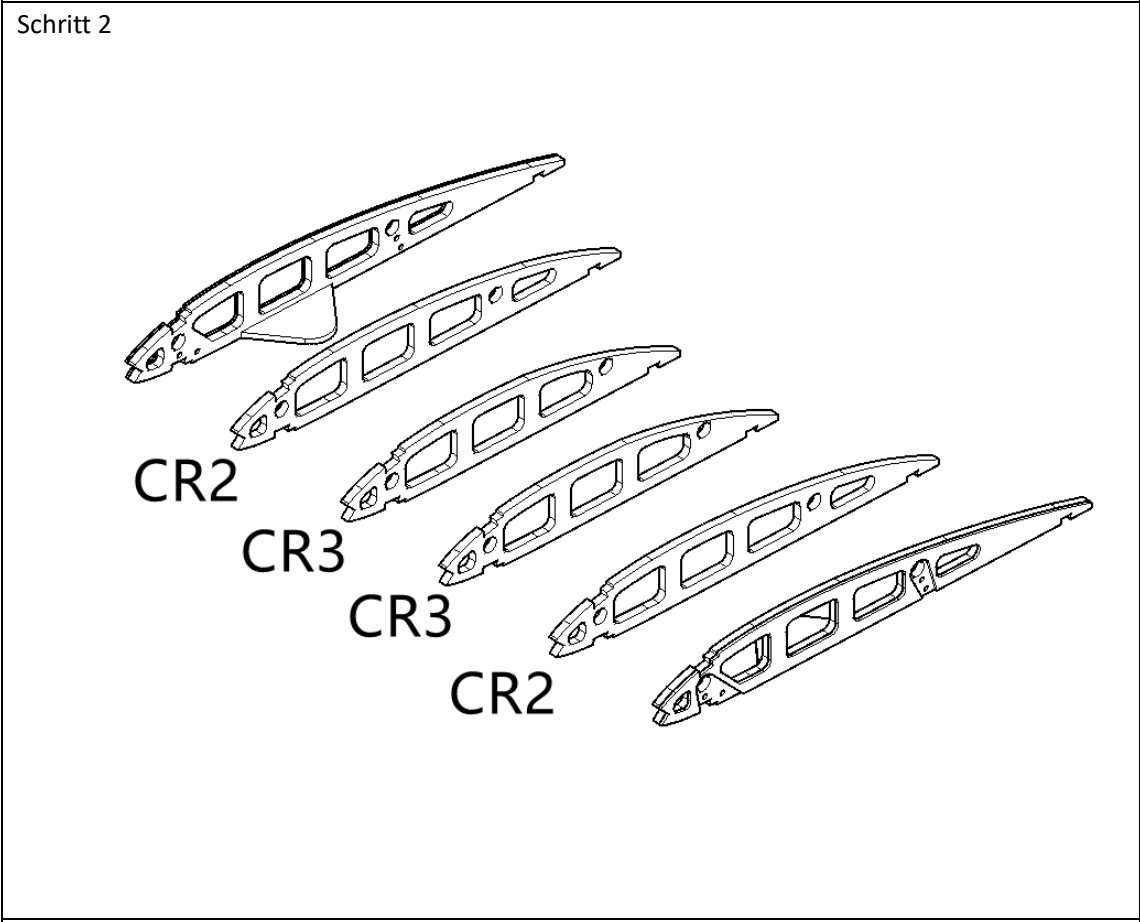

Schritt 3

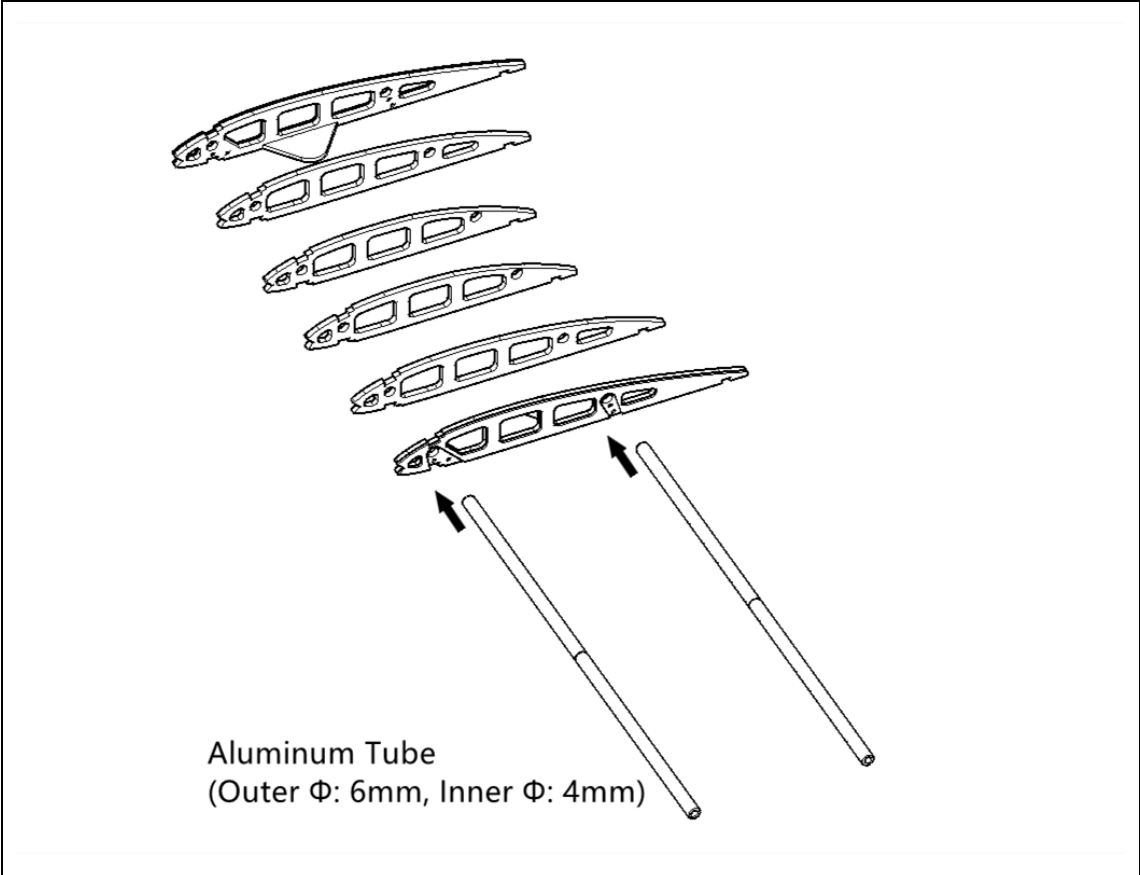

Schritt 4

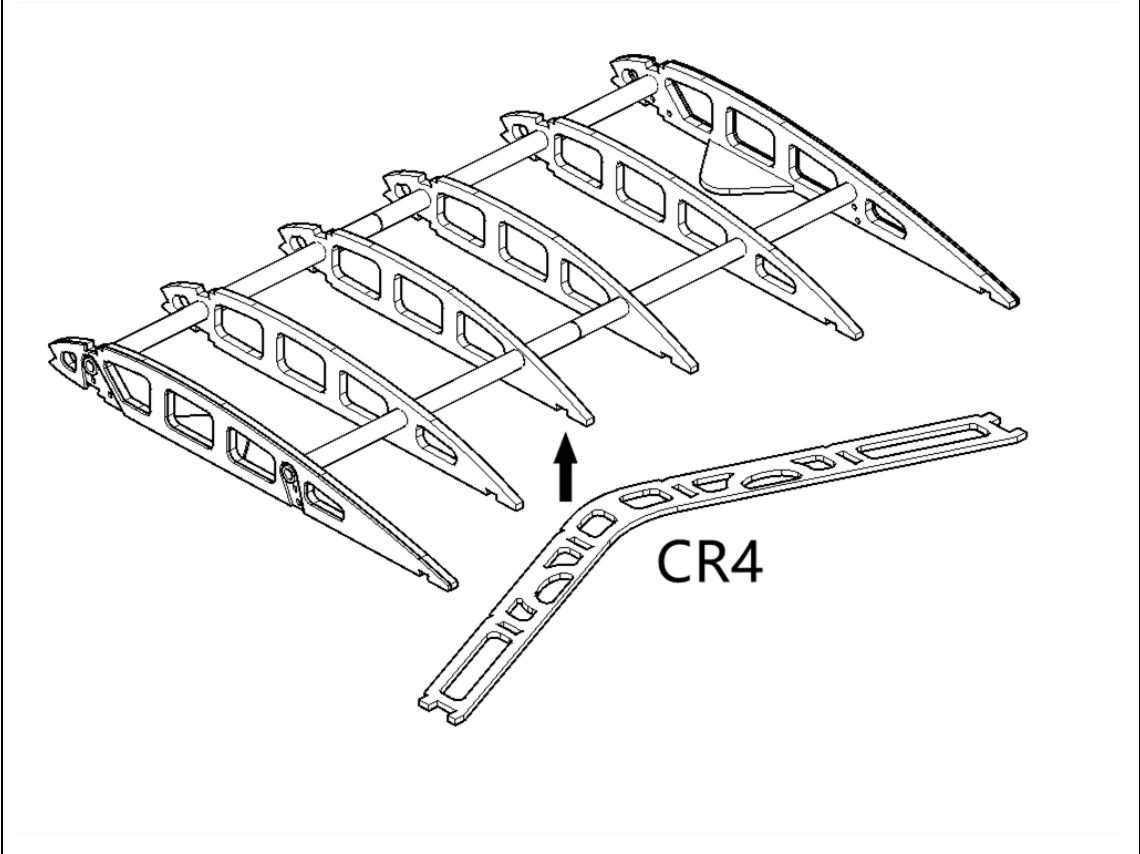

Schritt 5: 6 x 6 mm Balsa Leisten

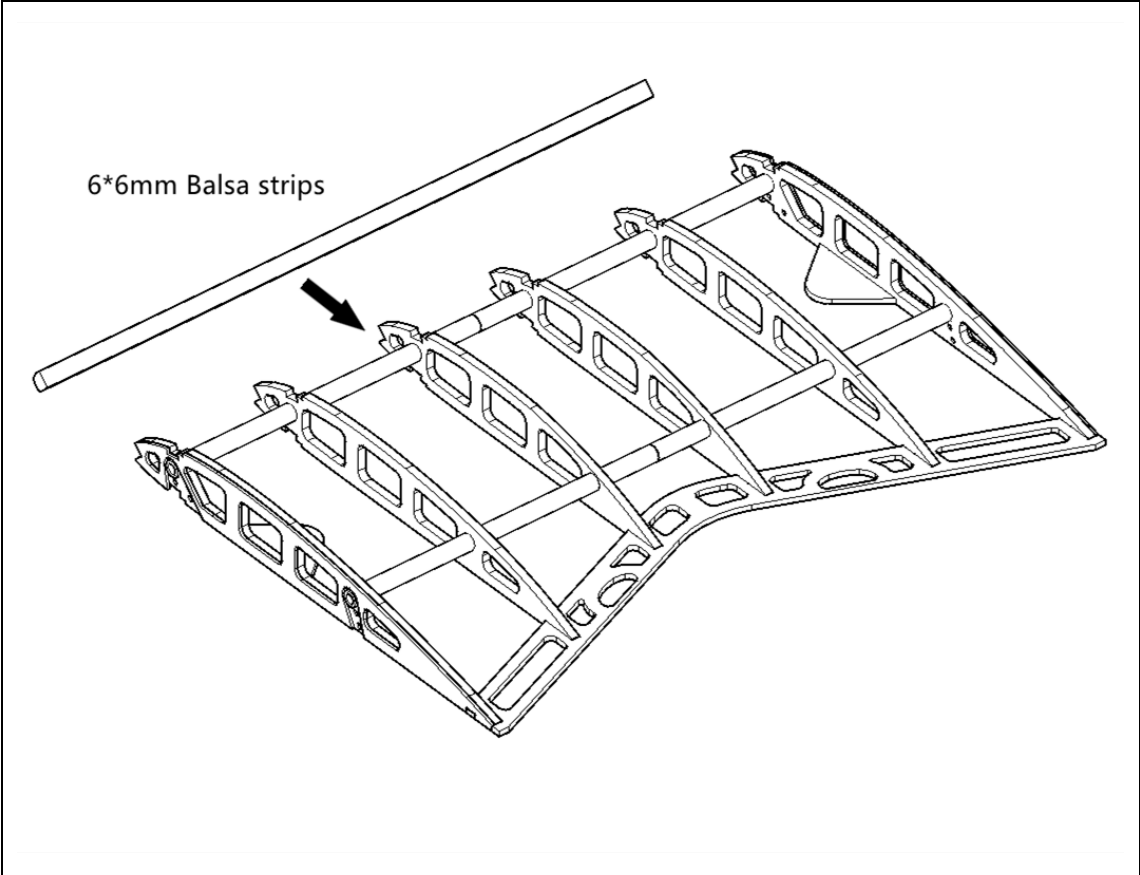

Schritt 6: 6 x 2 mm Kiefernleisten

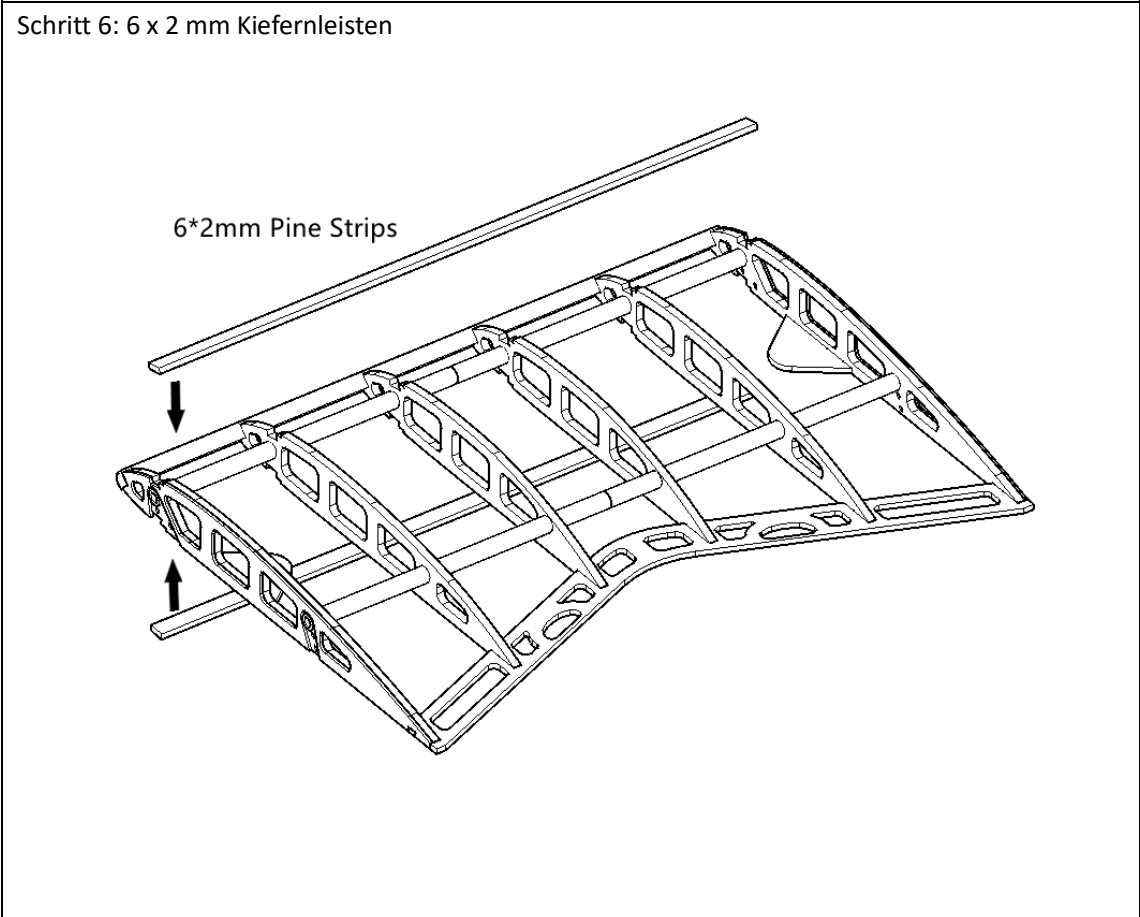

Schritt 7

WC1 UP

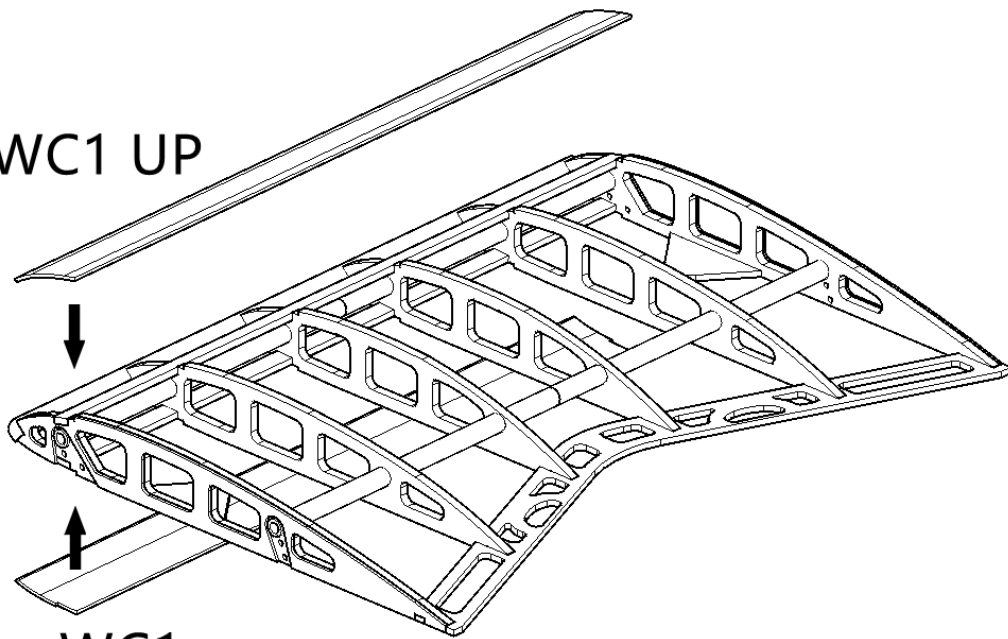

WC1

Schritt 8

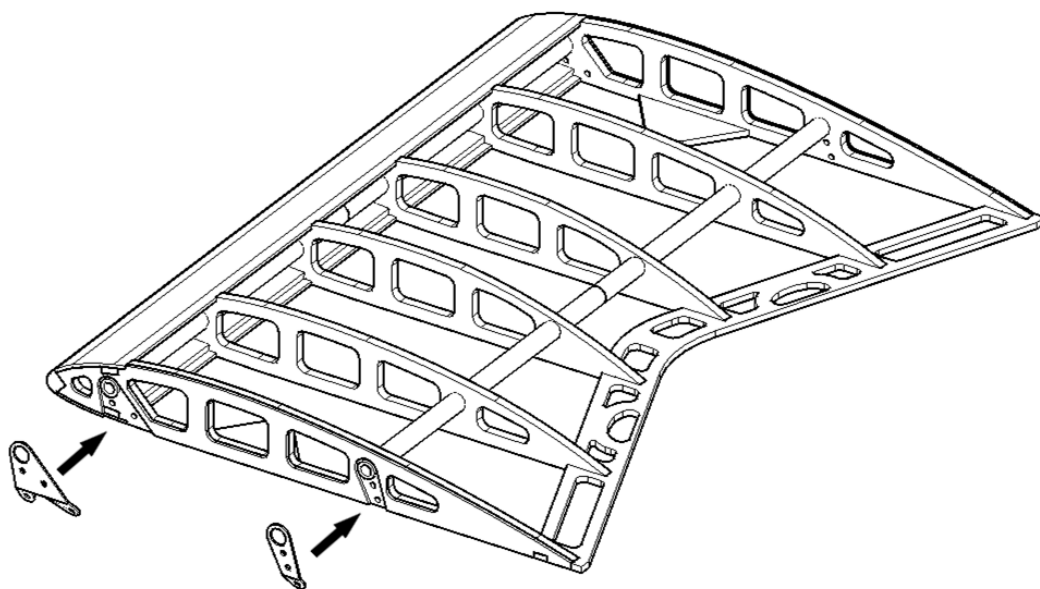

Schritt 9

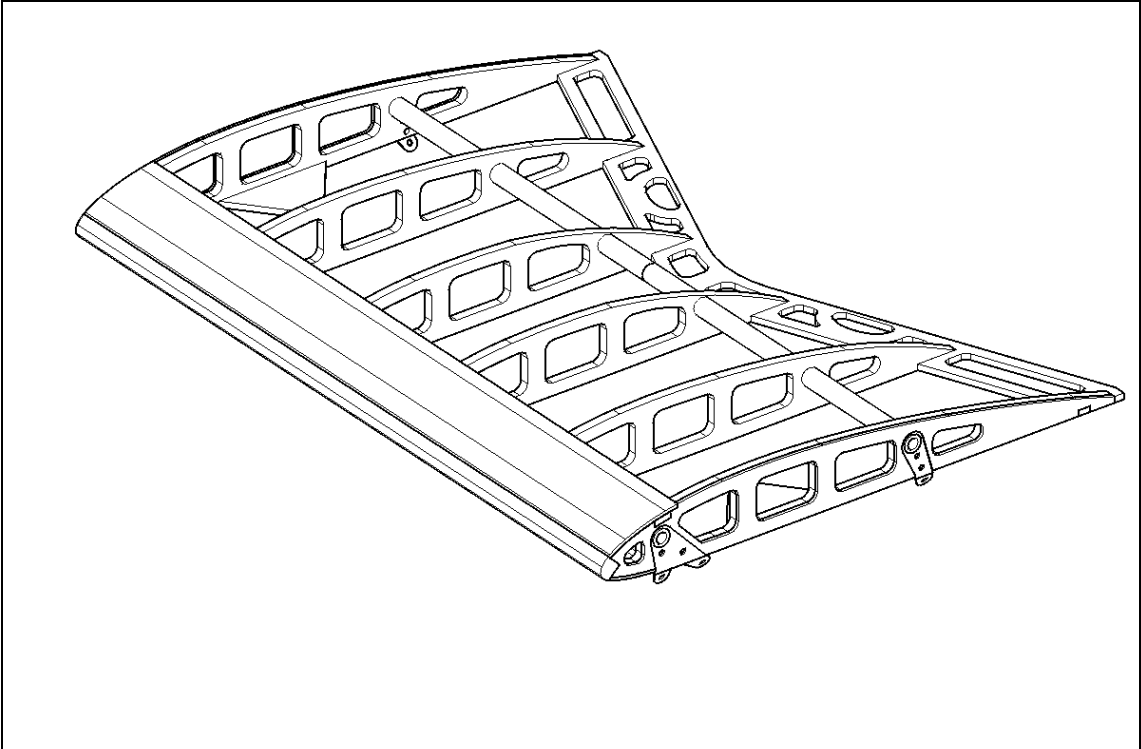

Schritt 10



Schritt 11



Schritt 12

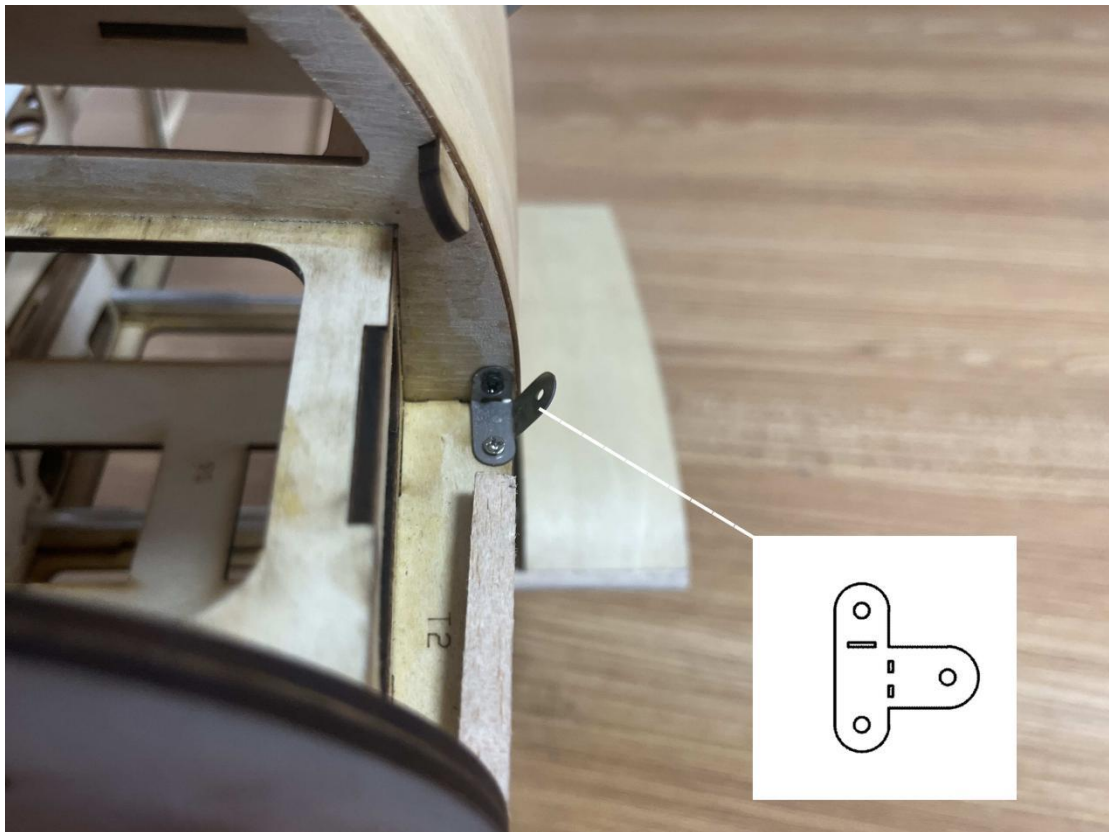

Schritt 13



Schritt 14



Schritt 15



Schritt 16: Vor dem Einbau um 90 Grad biegen

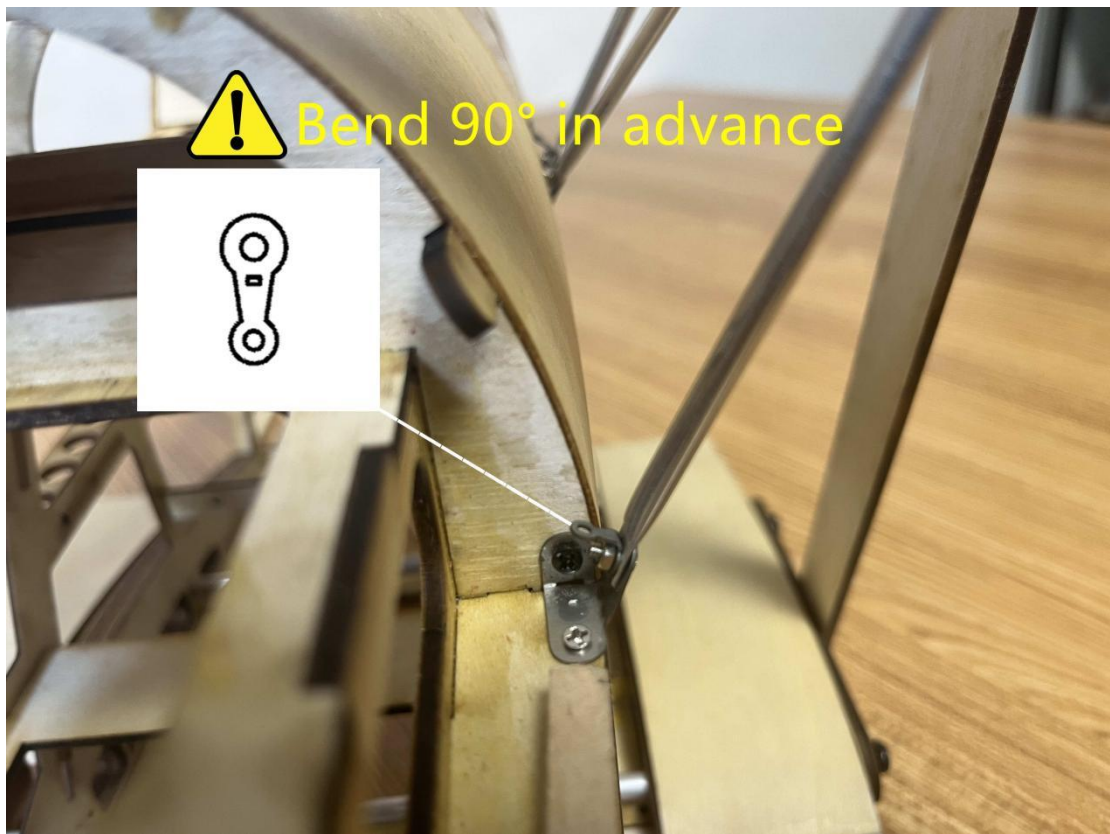

Schritt 17: Aluminium Röhrenchen mit 131 mm, 145 mm und 170 mm Länge (jeweils 4 mm Durchmesser)



Schritt 18: Vor dem Einbau um 90 Grad biegen

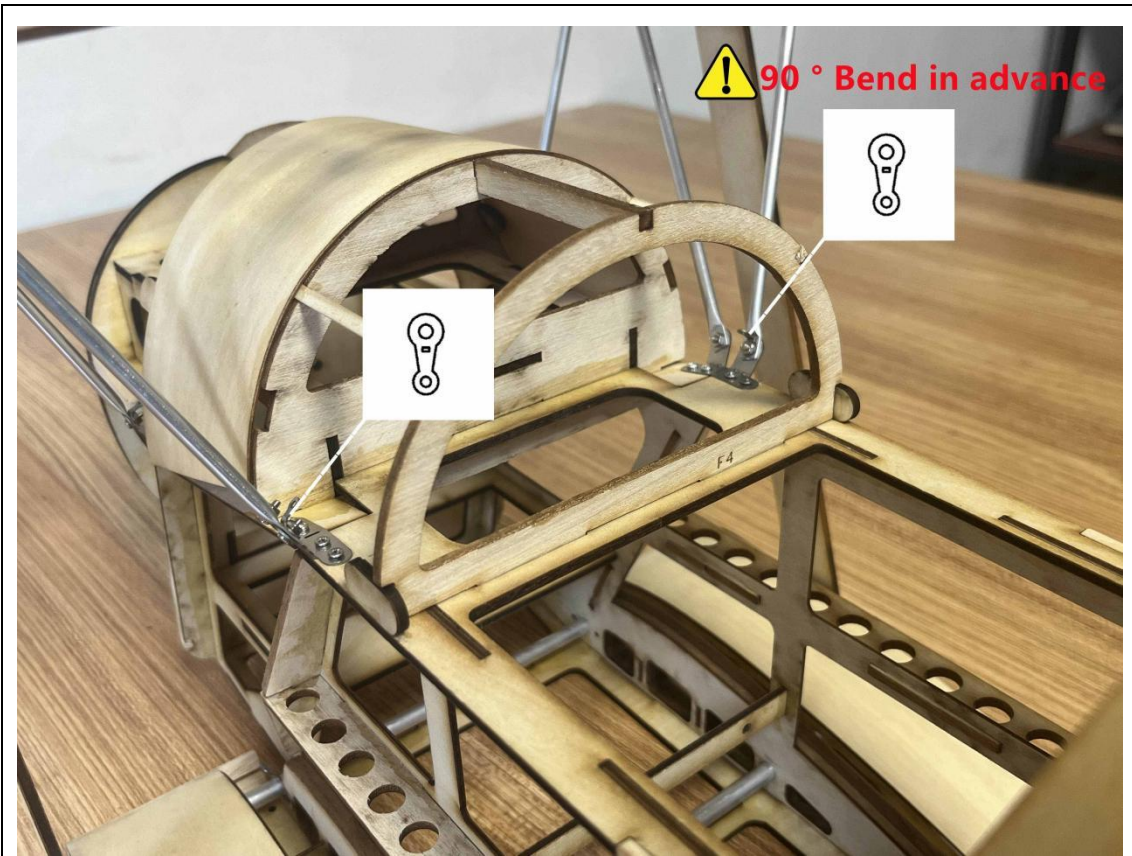

Step19



Schritt 20: 5 mm Balsa. Kunstleder.



Schritt 21





Tips: How to cover the parts using leather:

1. Apply a layer of glue on the components
2. Cover the parts with leather, making the front of the parts as tight as possible and without wrinkles
3. Use a small electric iron to adjust the temperature to 135 °C to iron the surface to solidify the glue
4. Brush the glue again at the edge of the leather, then iron it with an iron, stick to the edge, and press the folds. There can be wrinkles on the back

Schritt 21 – Kabinenhaube mit Kunstleder beziehen

Tipps zum Beziehen der Teile mit Kunstleder:

1. Tragen Sie eine dünne Schicht Klebstoff (Empfohlener Klebstoff: Holzleim; z. B. Titebond Original) auf die Bauteile auf.
2. Beziehen Sie die Teile mit dem Kunstleder und spannen Sie die sichtbare Vorderseite möglichst straff und faltenfrei.
3. Stellen Sie ein kleines Bügeleisen auf ca. 135 °C ein und bügeln Sie die Oberfläche, um den Klebstoff zu aktivieren und zu fixieren.
4. Tragen Sie an den Kanten nochmals Klebstoff auf. Bügeln Sie die Kanten an, schlagen Sie das Material um und drücken Sie die Falten fest an. Kleine Falten auf der Rückseite sind zulässig.

4. Montage – Kabinentüren und Verkleidung

Schritt 1: Aluminiumbleche entsprechend der Schablonen zuschneiden.



Cut the aluminum sheets according to the templates

Schritt 2: Aluminiumbleche vorsichtig in Form bringen



Schritt 3: Obere Kante wie dargestellt abwinkeln. 6 x 6 mm Balsa Leisten.

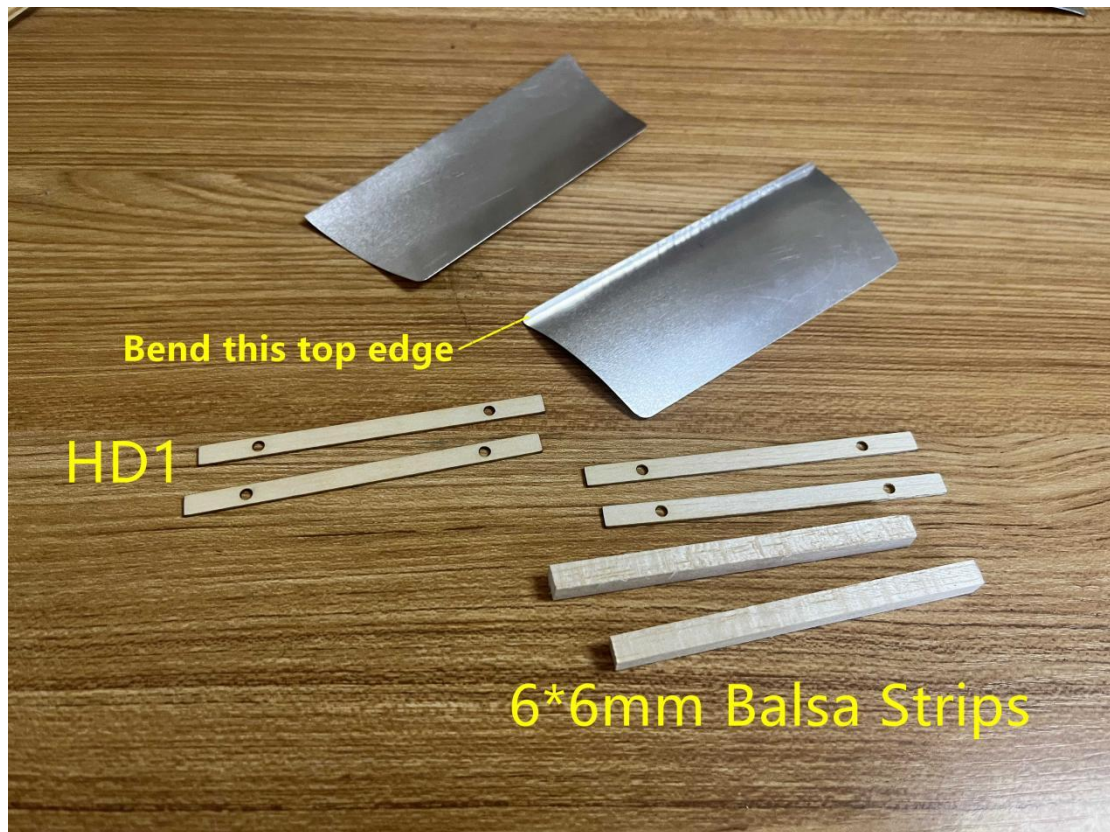

Schritt 4: Magnete – Polarität beachten!

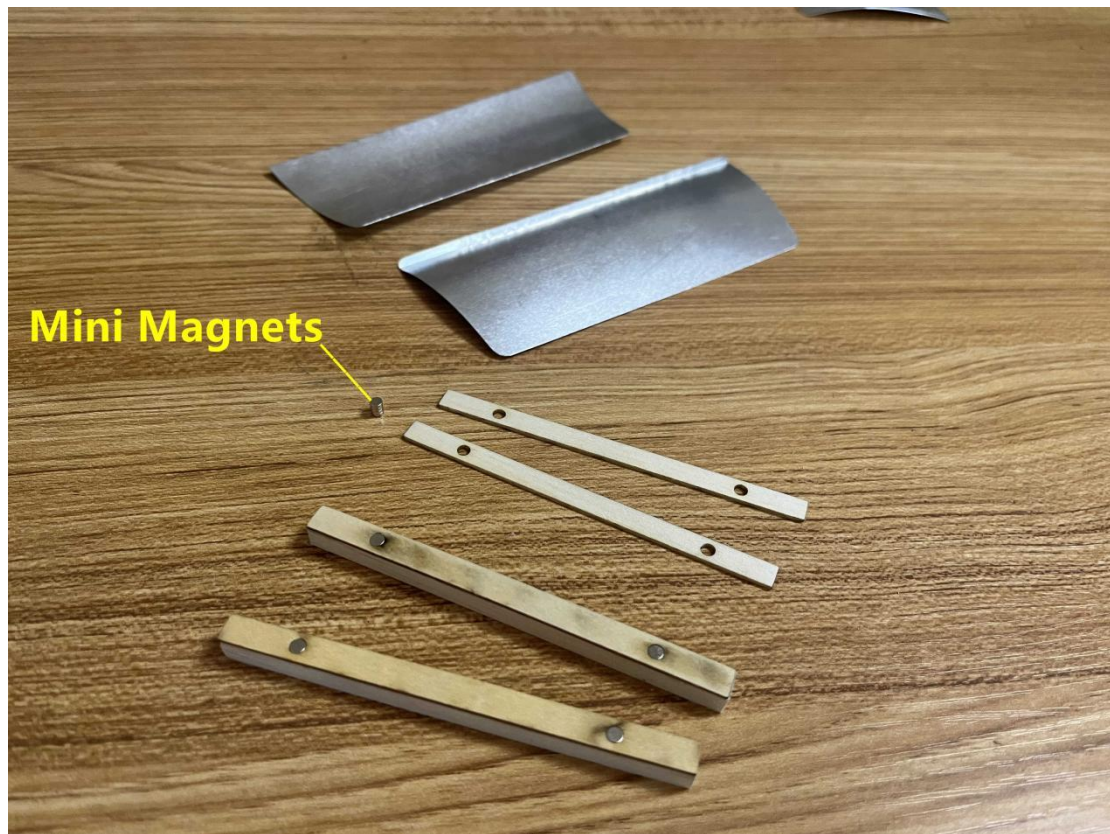

Schritt 5: Magnete – Polarität beachten!



Schritt 6: Scharniere mit M1.2 x 4 mm Schrauben. M1.6 x 6 Schraube und Mutter.

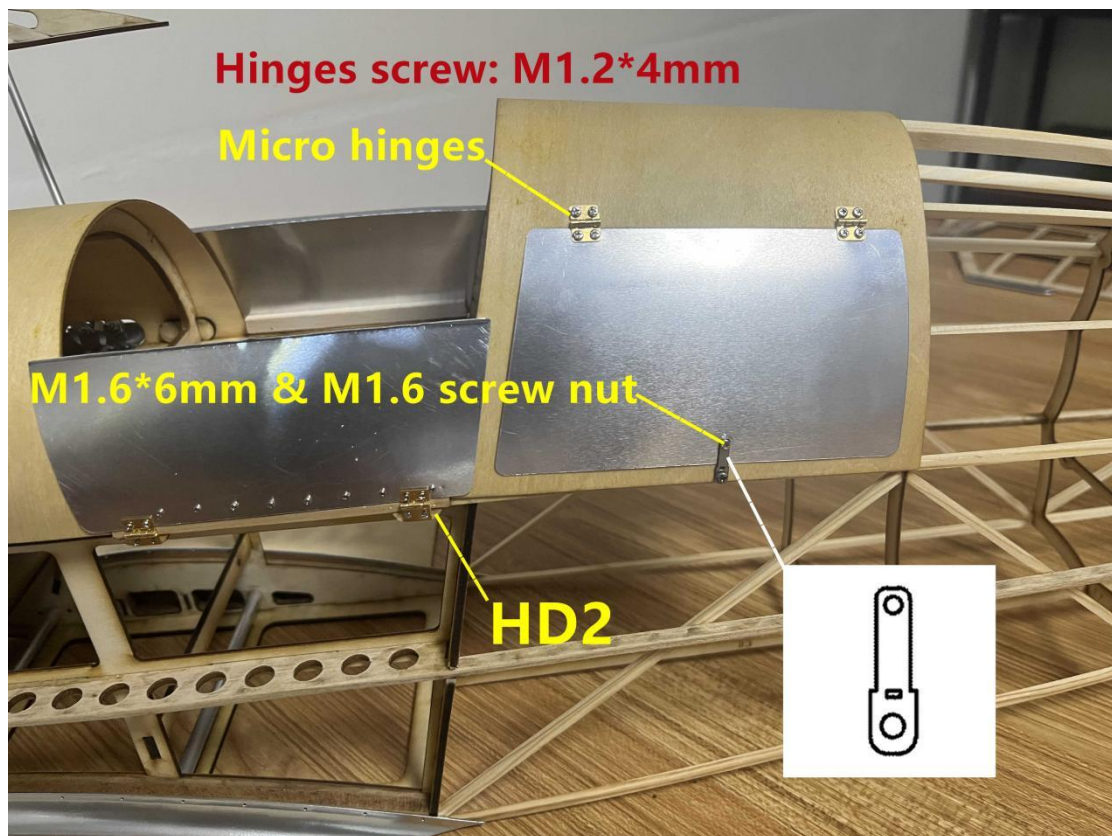

Schritt 7: 0,5 mm Klarsicht PVC Abdeckung

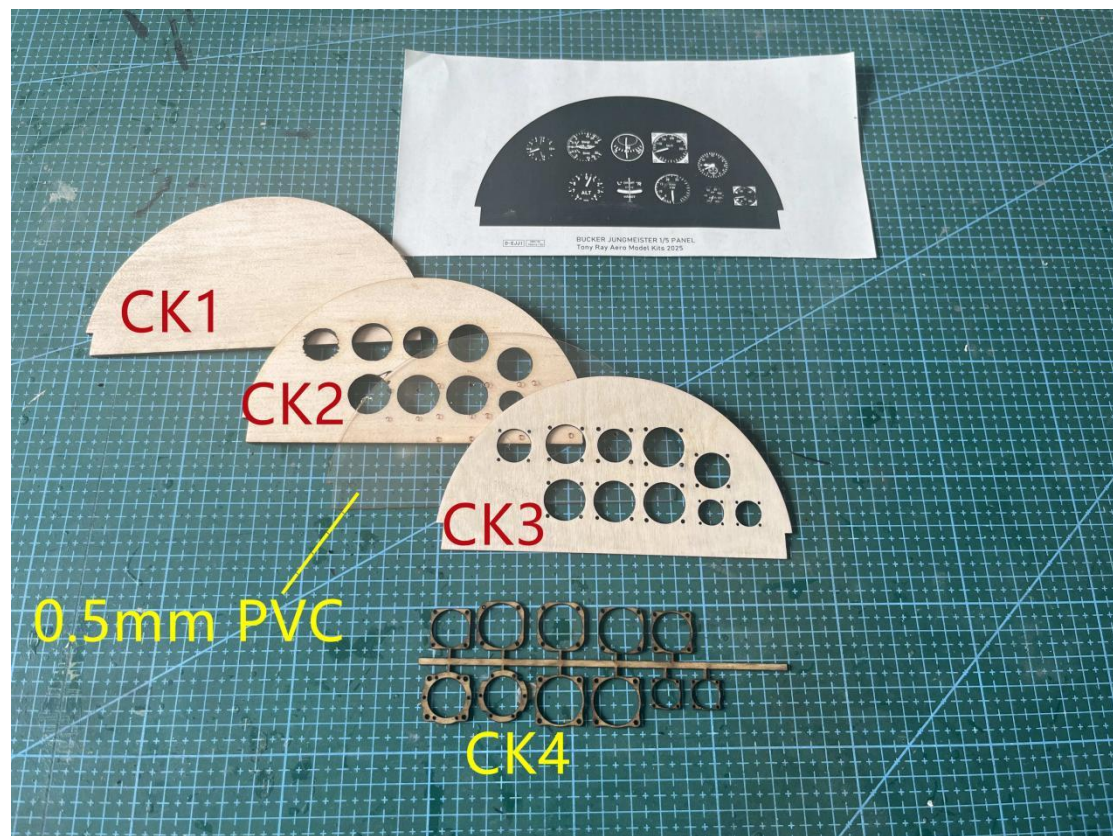

Schritt 8



5. Montage - Fahrgestell

Schritt 1: M3-Gewindestange (60 mm), 2× Zylindermuttern M3, 2× Muttern M3, Kupferbuchse, Feder und Beschlagplatte.



Schritt 2: 127 mm Metallröhrchen (6 mm Durchmesser)



Schritt 3

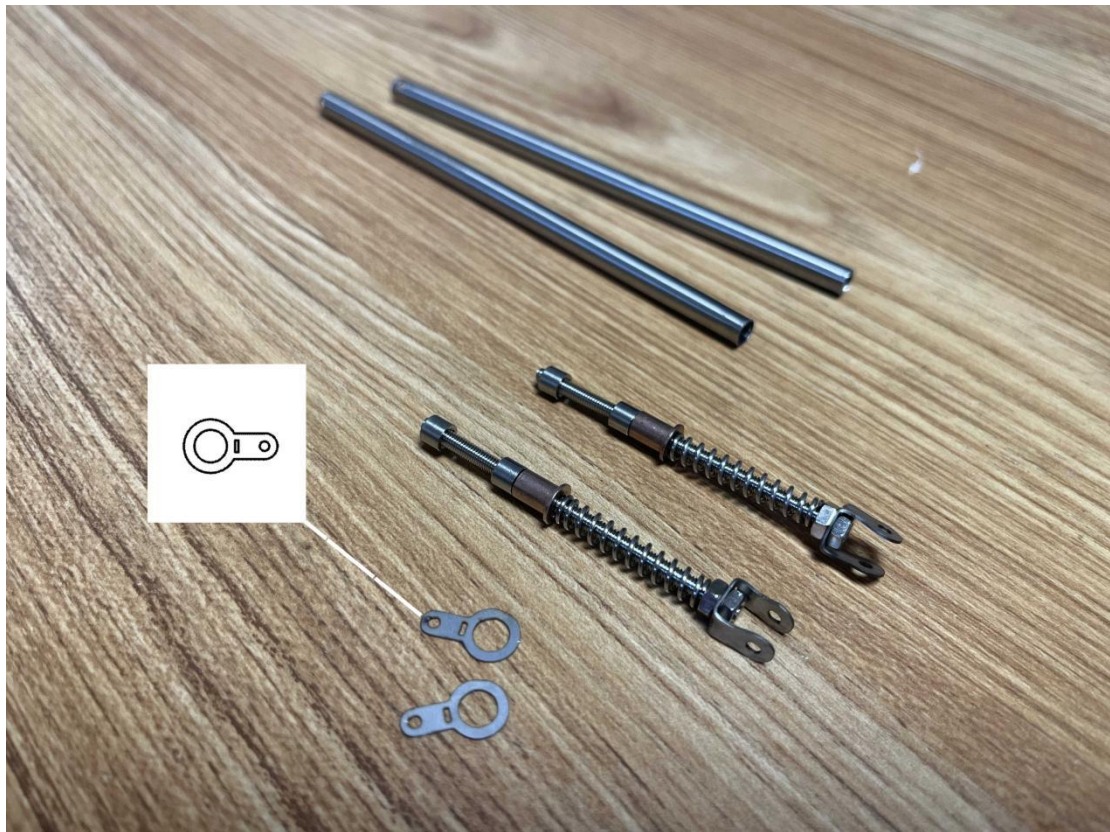

Schritt 4: Unterschiedliche Durchmesser der Buchsen beachten

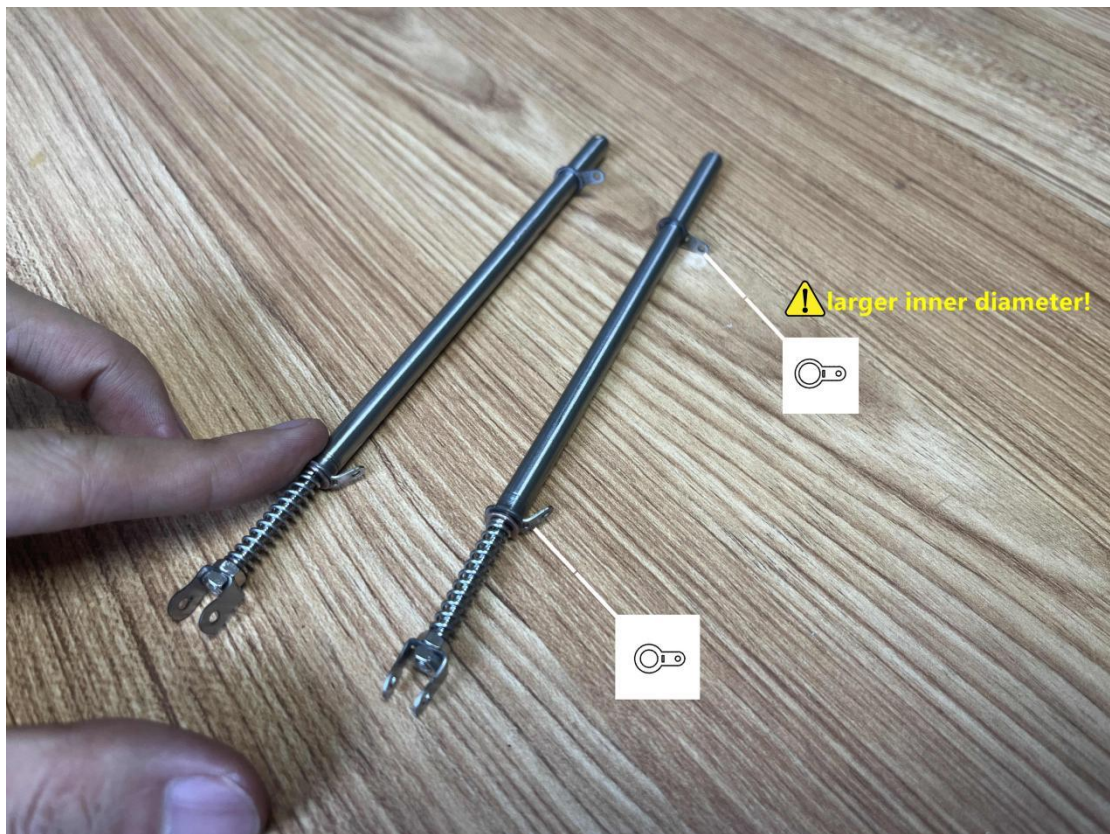

Schritt 5: M1.6 Schrauben. 168 mm Aluminium Röhren (3 mm Durchmesser). Abstand der äußeren Bohrungen: 161,5 mm.



Schritt 6: Feder, Beschlag und Muttern demontieren und Teil LD4 montieren.

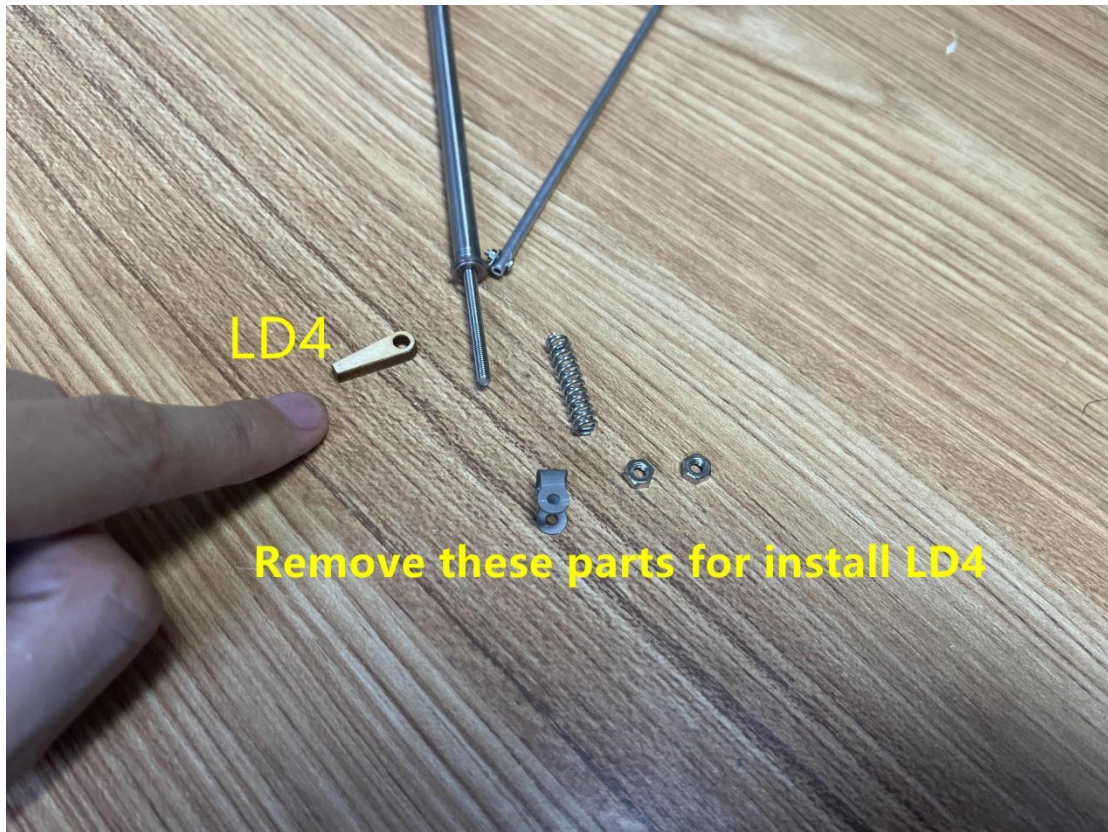

Schritt 7



Schritt 8: Kante anpassen

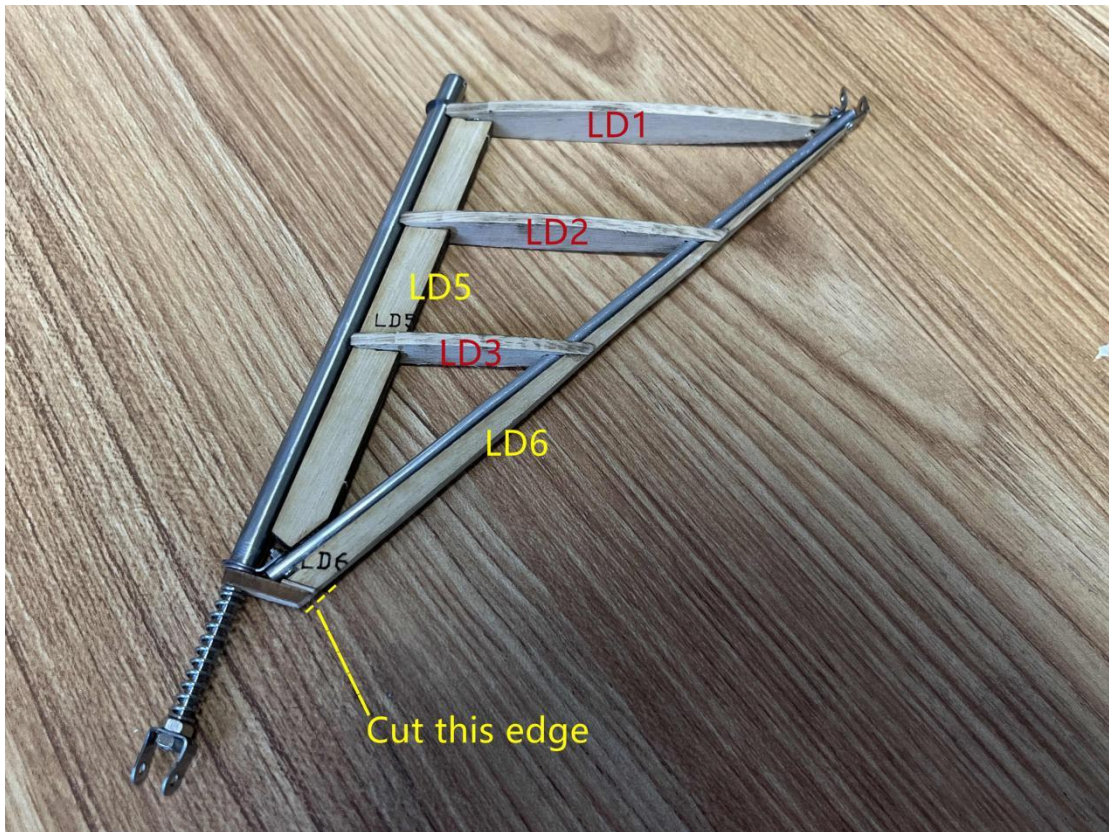

Schritt 9: M2 x 15 Schraube, M2 Mutter

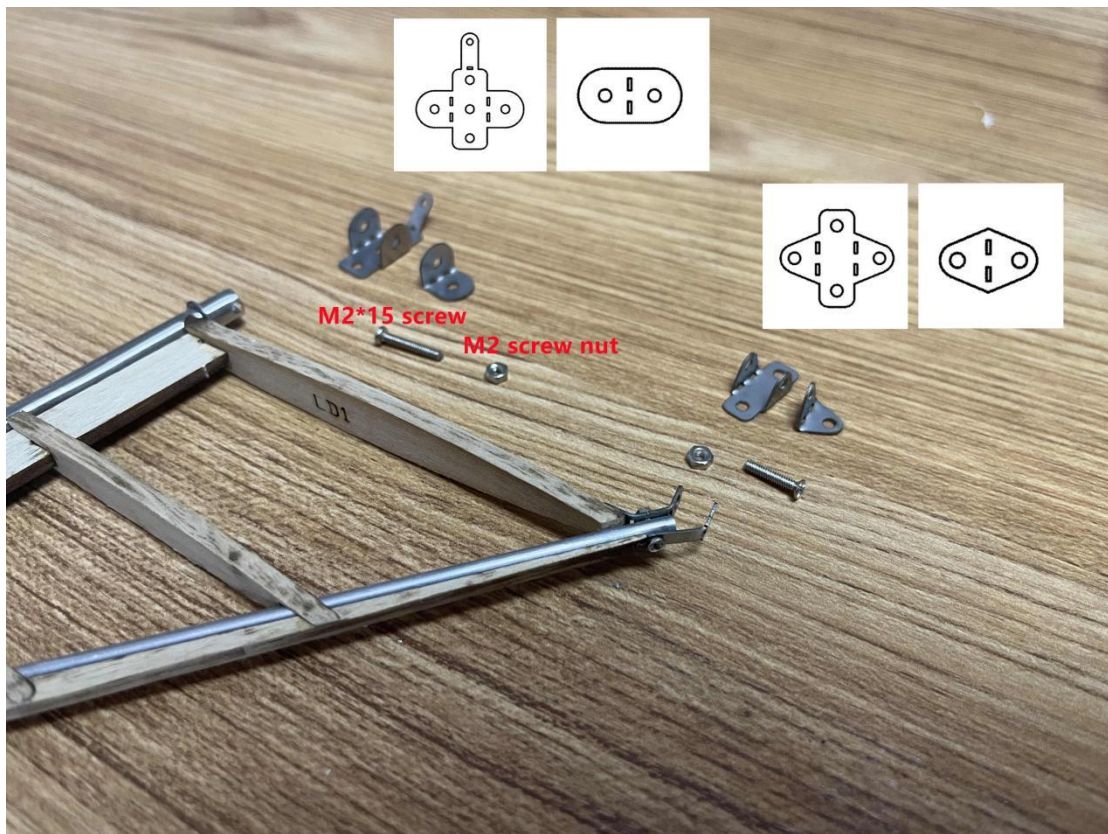

Schritt 10: M2 x 10 Schraube

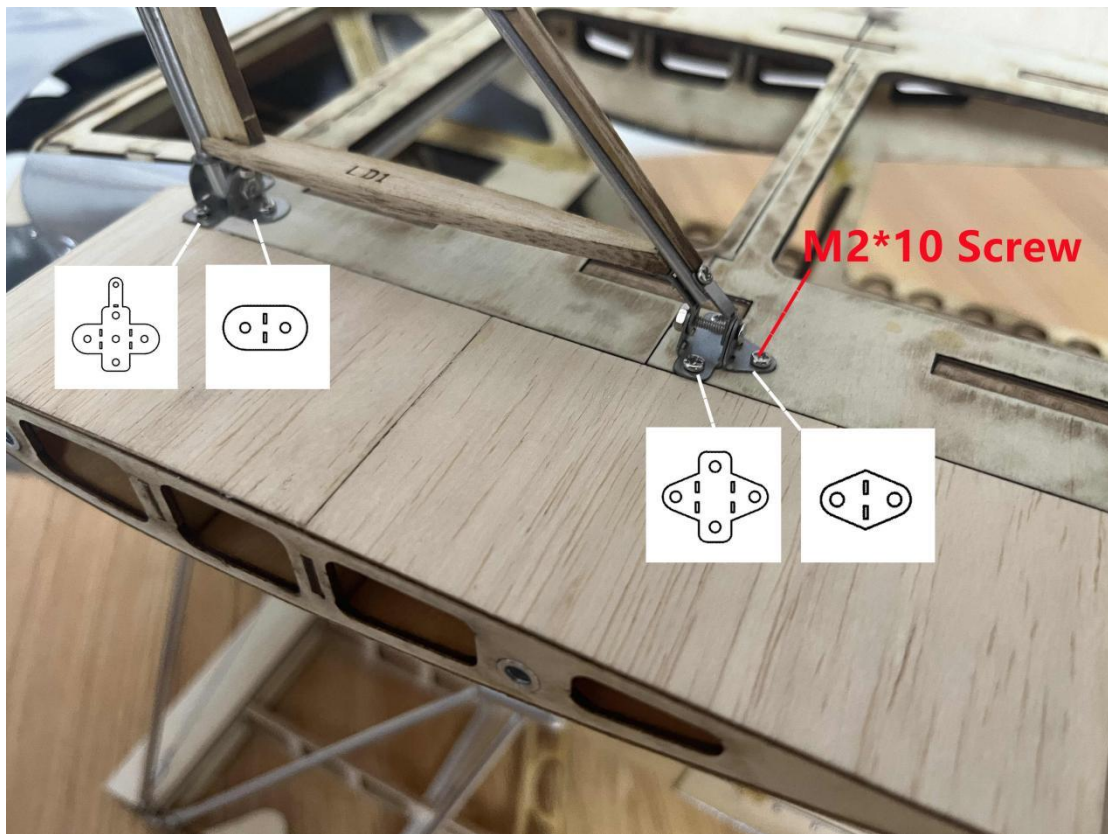

Schritt 11

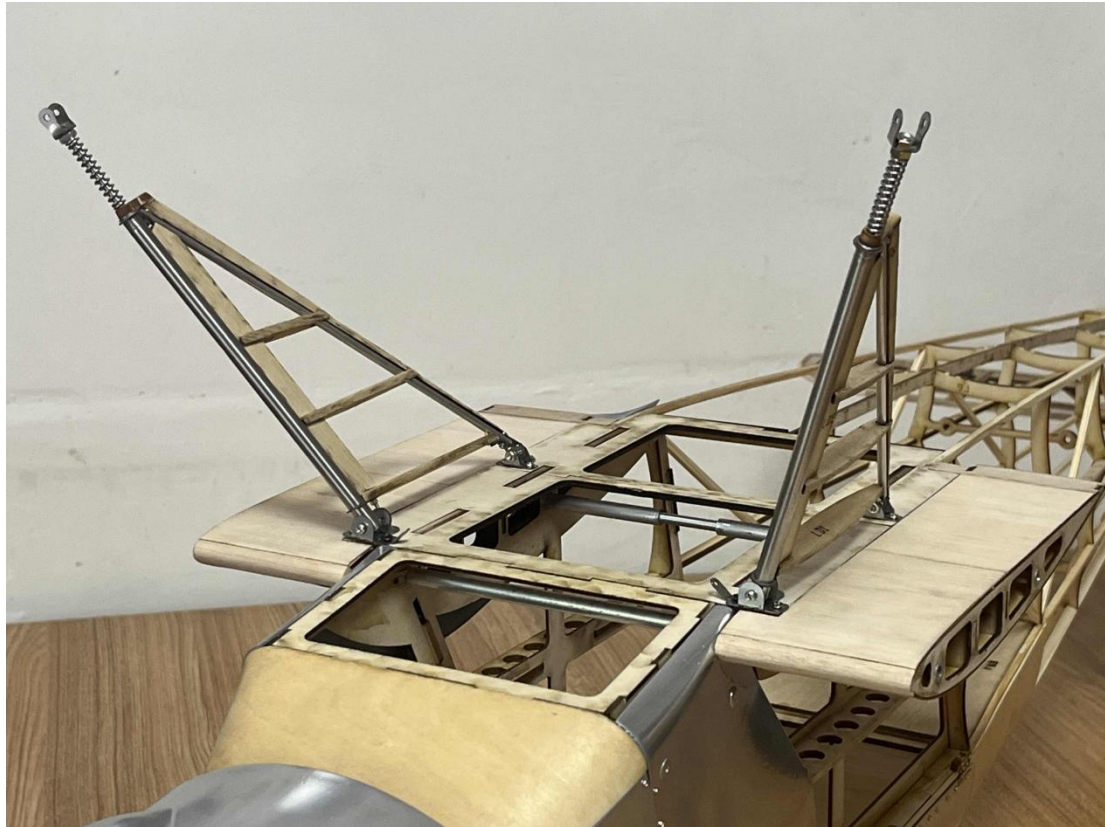

Schritt 12: Aluminiumrohre $\varnothing 4 \times 100$ mm, Metallrohre $\varnothing 4 \times 149$ mm und M3-Gewindestangen 40 mm wie dargestellt montieren. Lochabstand 94,5 mm.



Schritt 13: M1.6 und M2 Schraube.

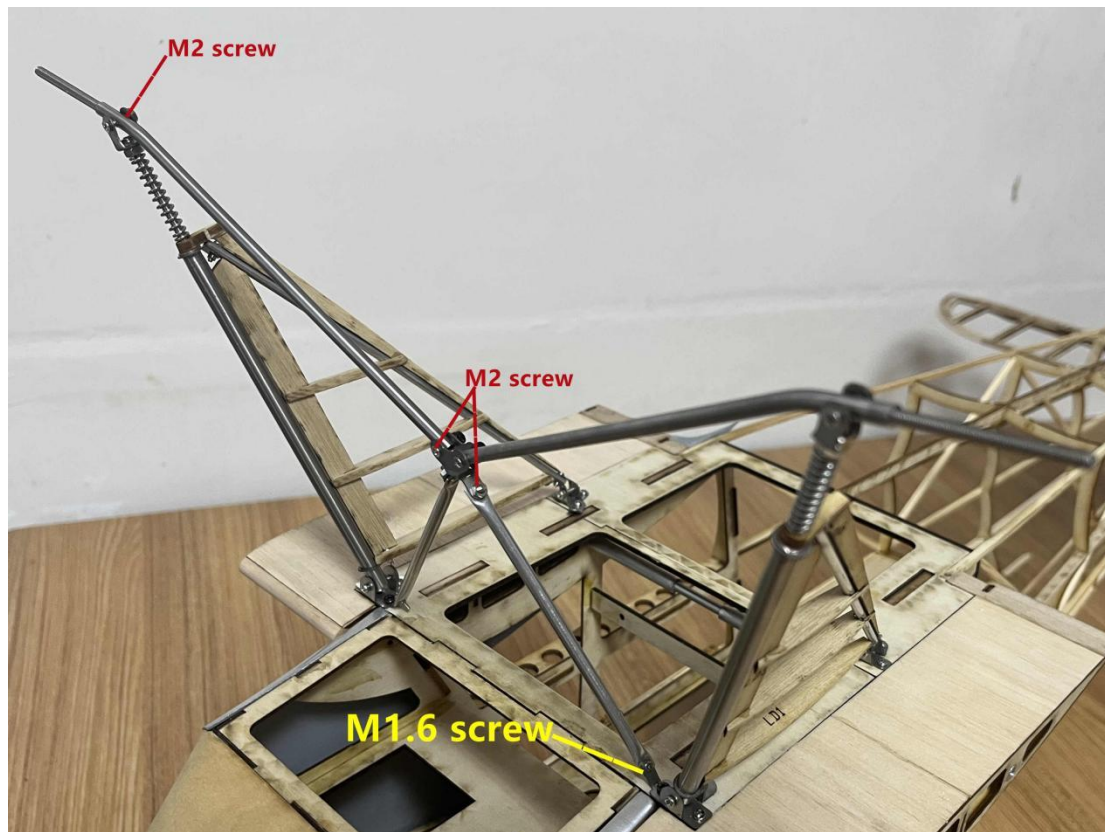

Schritt 14: Beschlag nur auf der linken Seite montieren.

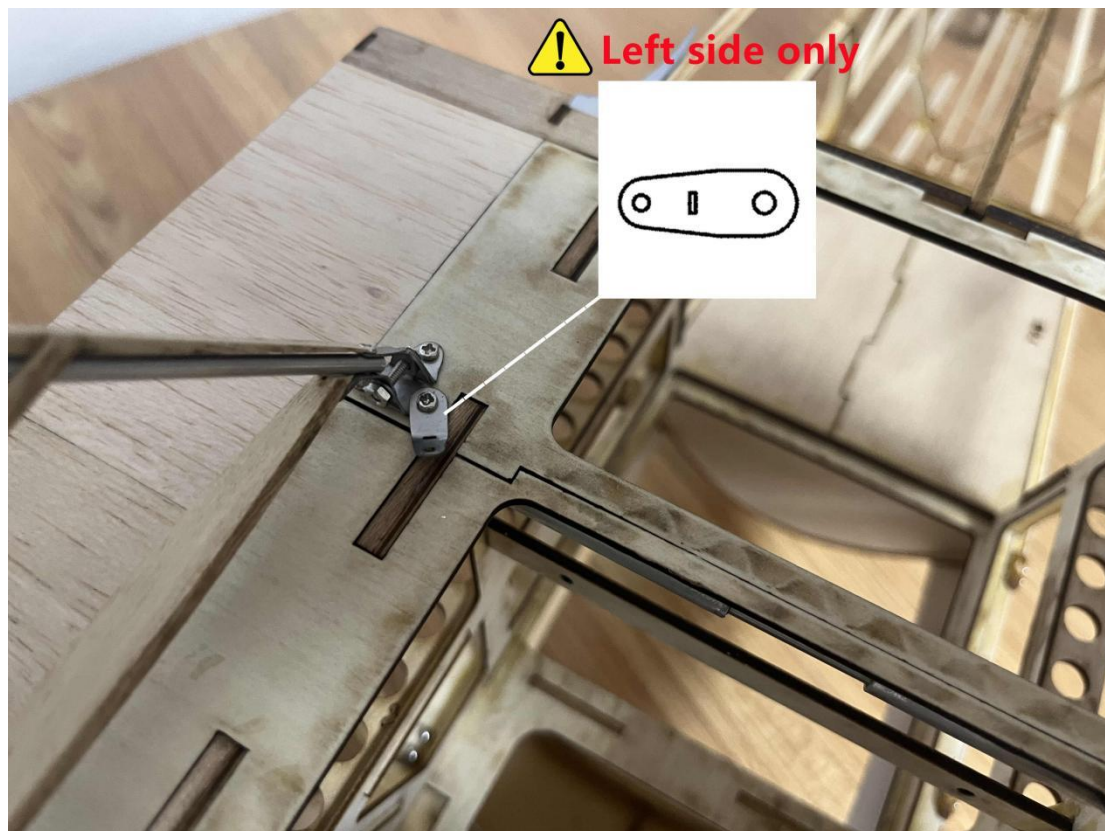

Schritt 15

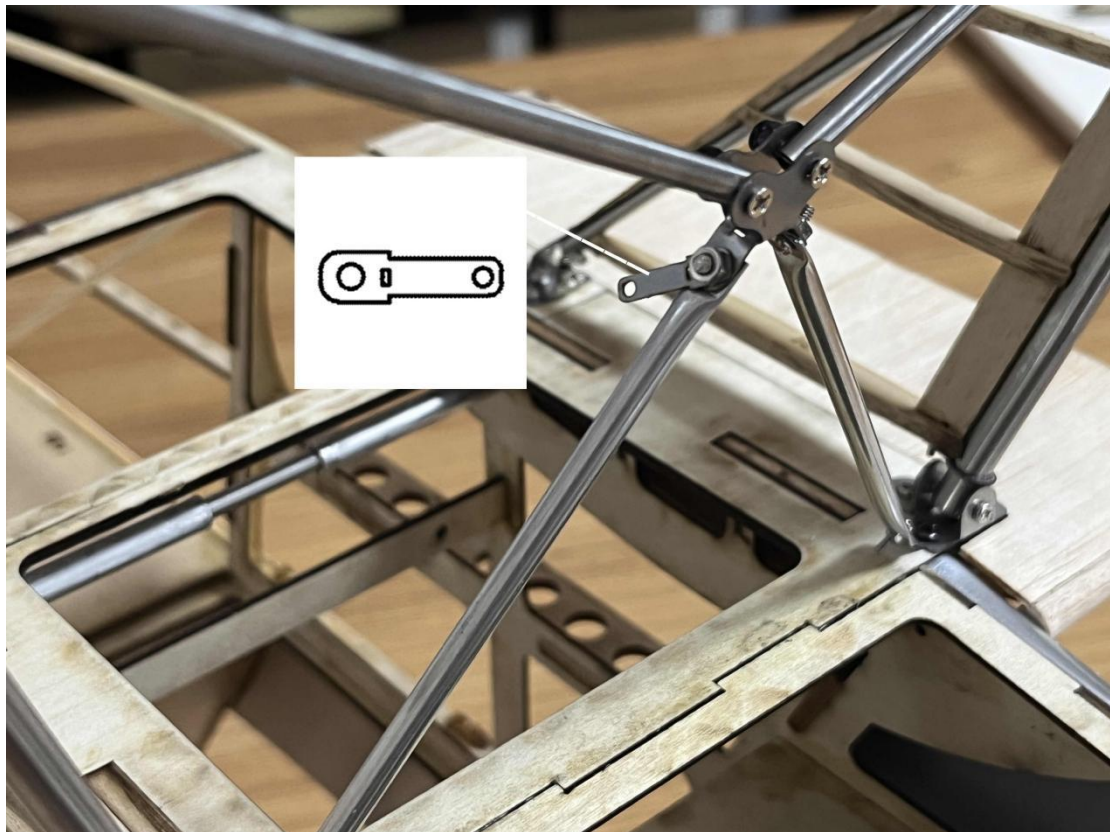

Schritt 16: M1.6 Schraube. 137 mm Aluminiumröhrchen (3 mm Durchmesser)

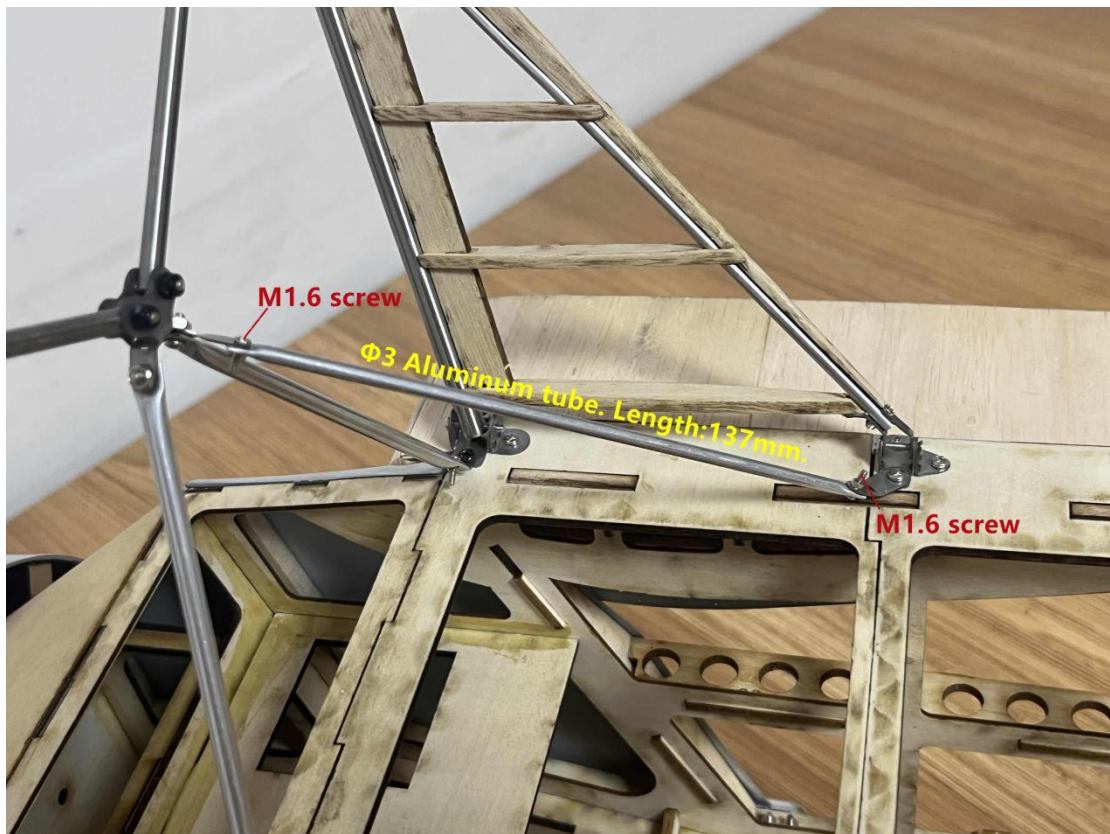

Schritt 17: M3 Sperrzahnmutter

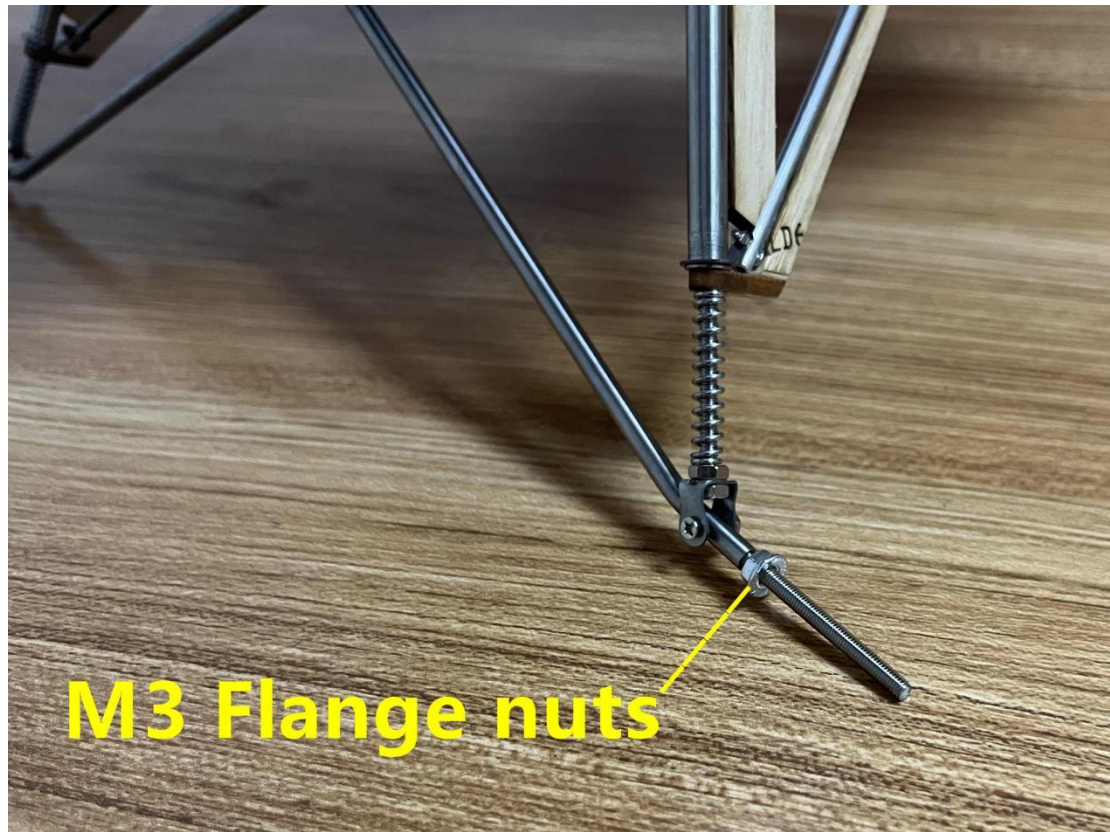

Schritt 18



6.Montage - Motorhaube

Schritt 1: 0,1 mm Glasfasermatte



Schritt 2: Zur inneren Versteifung



Schritt 3: Motorhaube verschleifen und glätten.



Schritt 4: Nach dem Auftragen der Grundierung verschleifen.

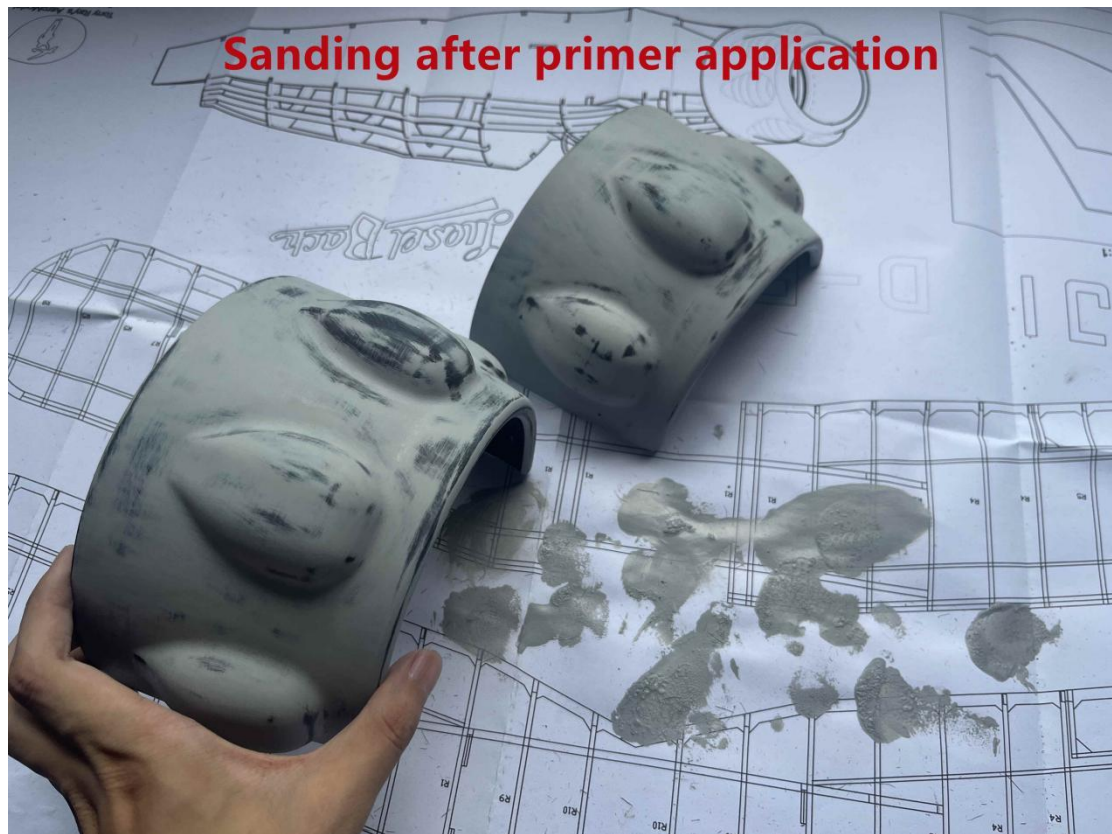

Schritt 5



Schritt 6: 4 x Motorhaubenhalter

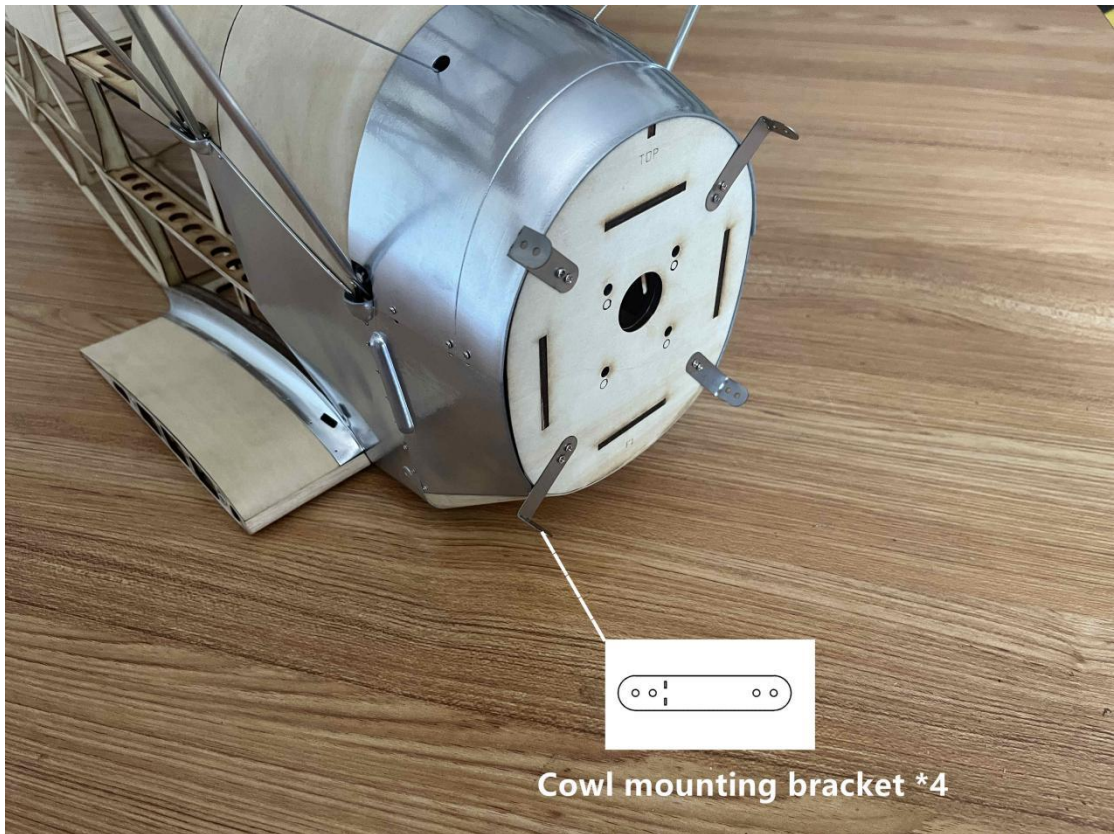

7. Montage – Untere Tragfläche

Schritt 1: 2 x 6 mm Kiefernleisten

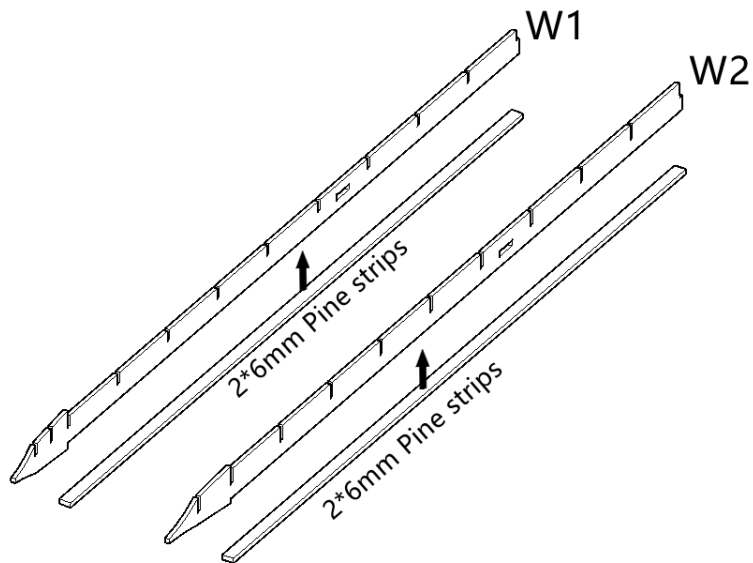

Schritt 2

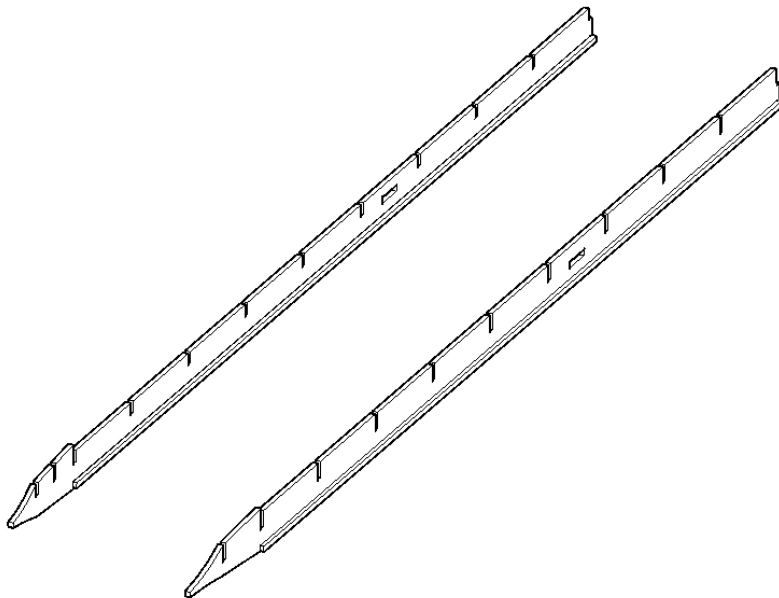

Schritt 3

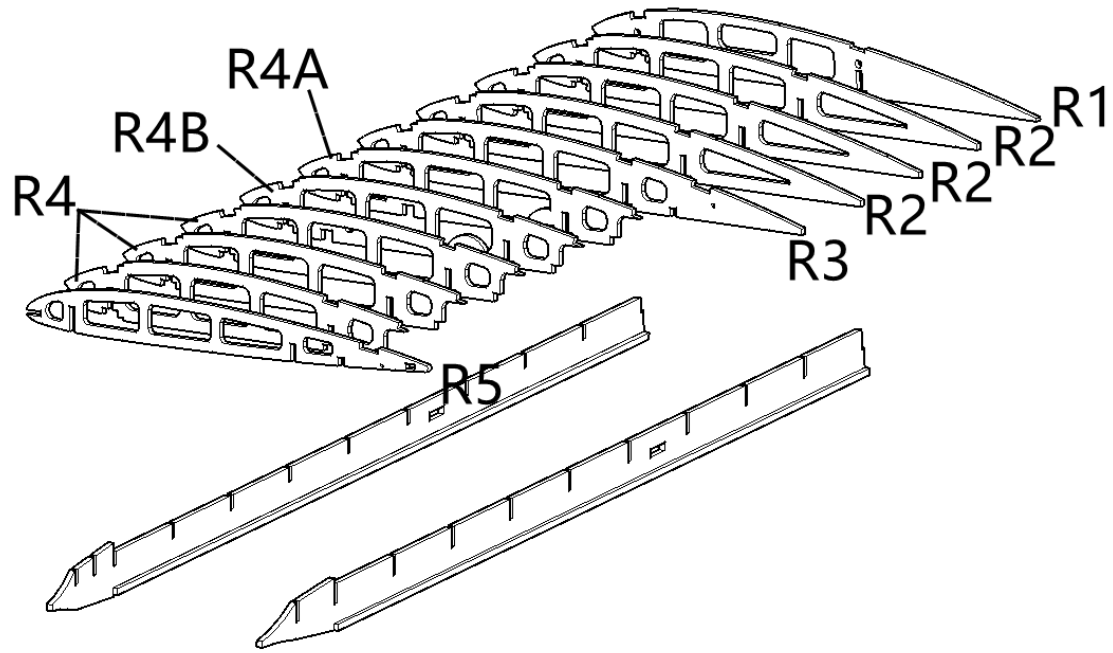

Schritt 4

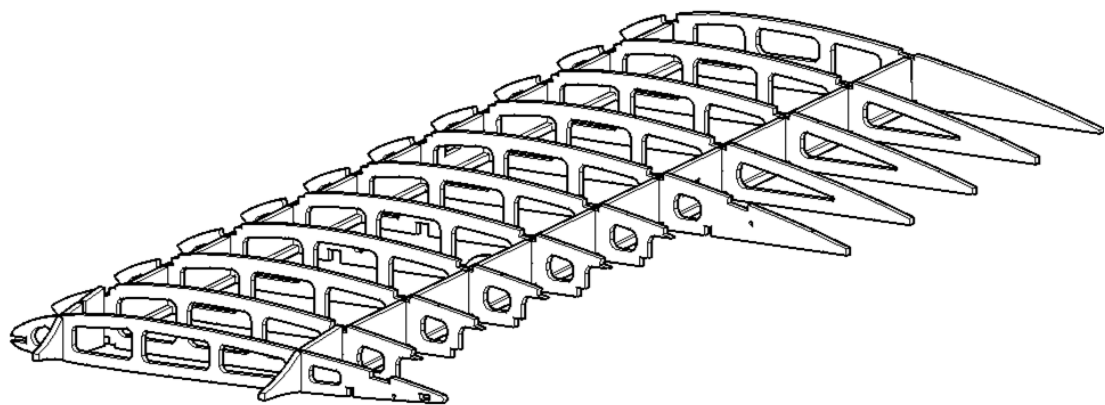

Schritt 5: 6 x 6 mm Balsa Leisten

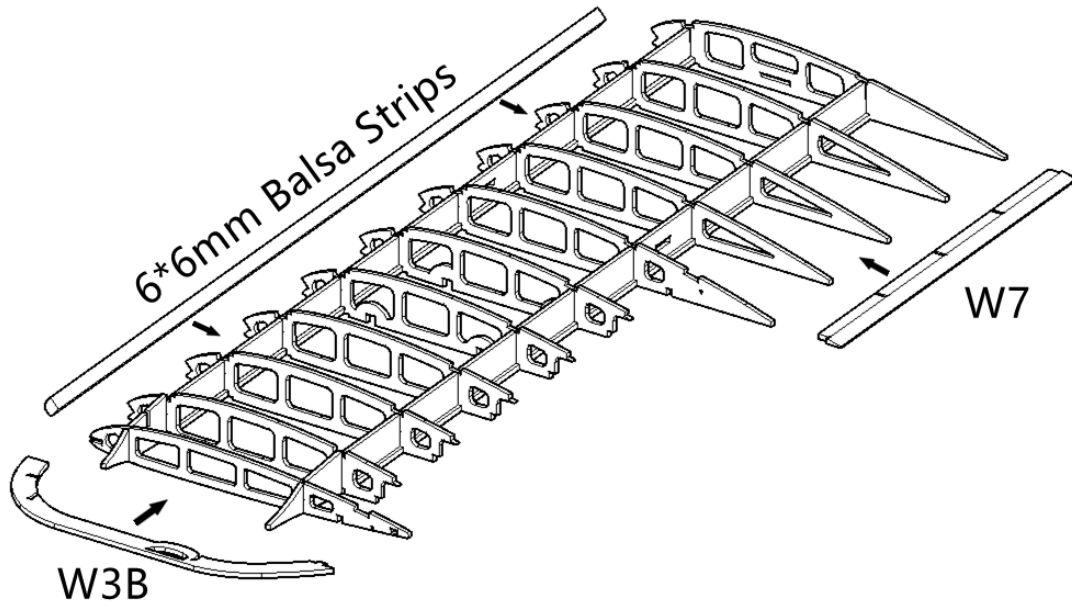

Schritt

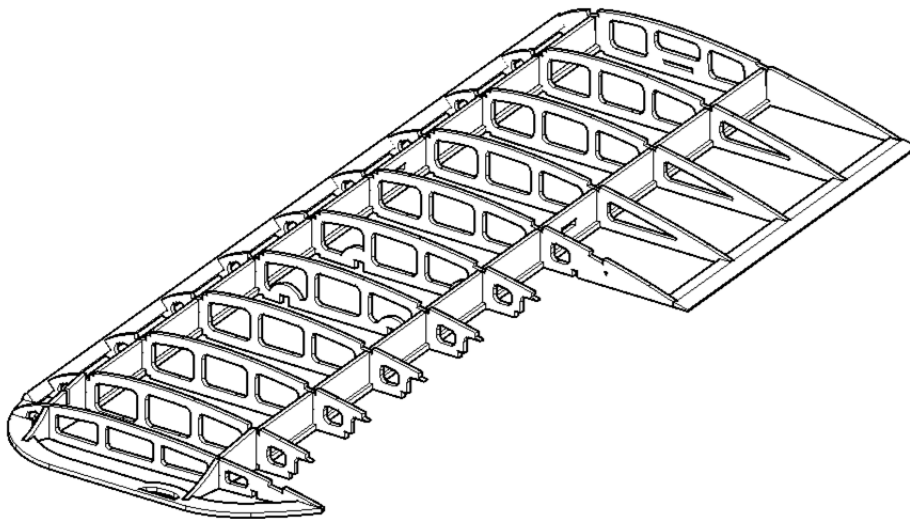

Schritt 7: 6 x 2 mm Kiefernleisten

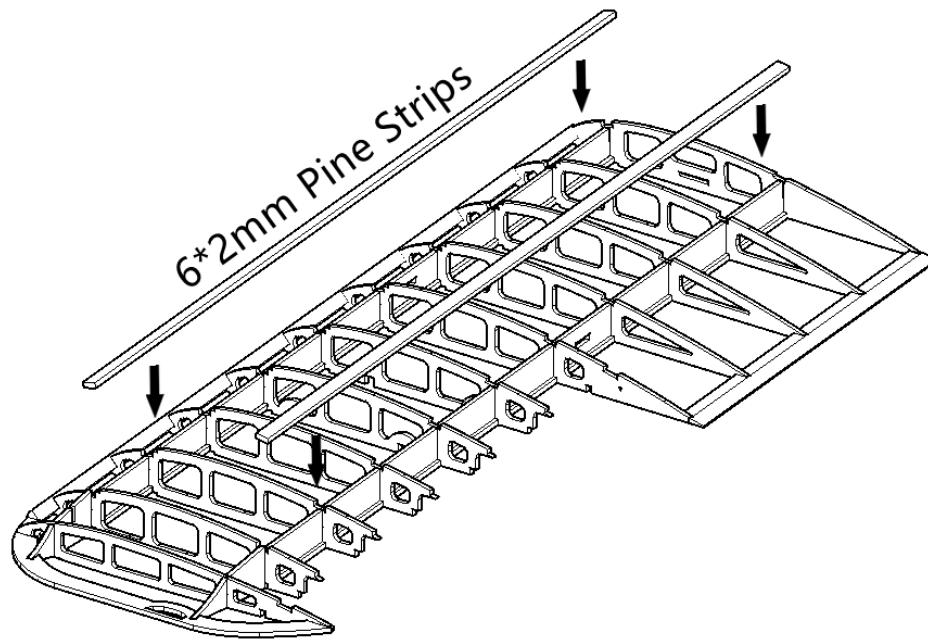

Schritt 8

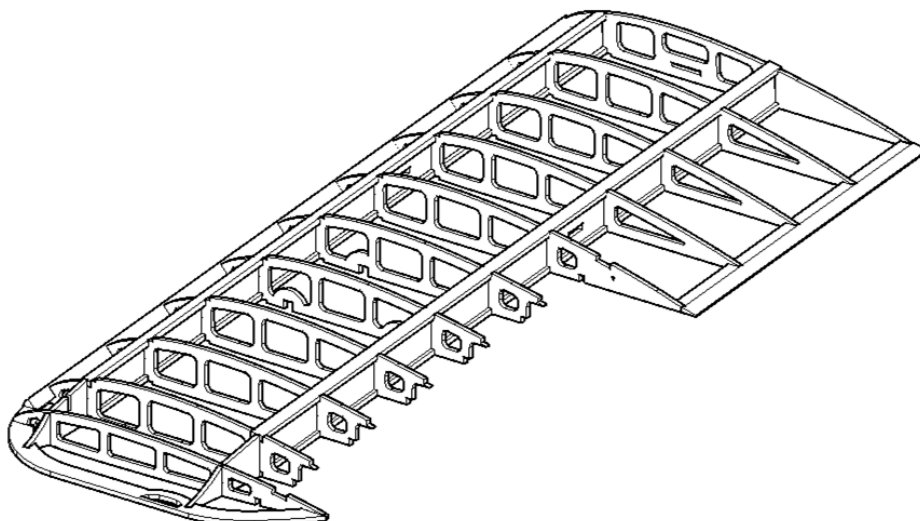

Schritt 9

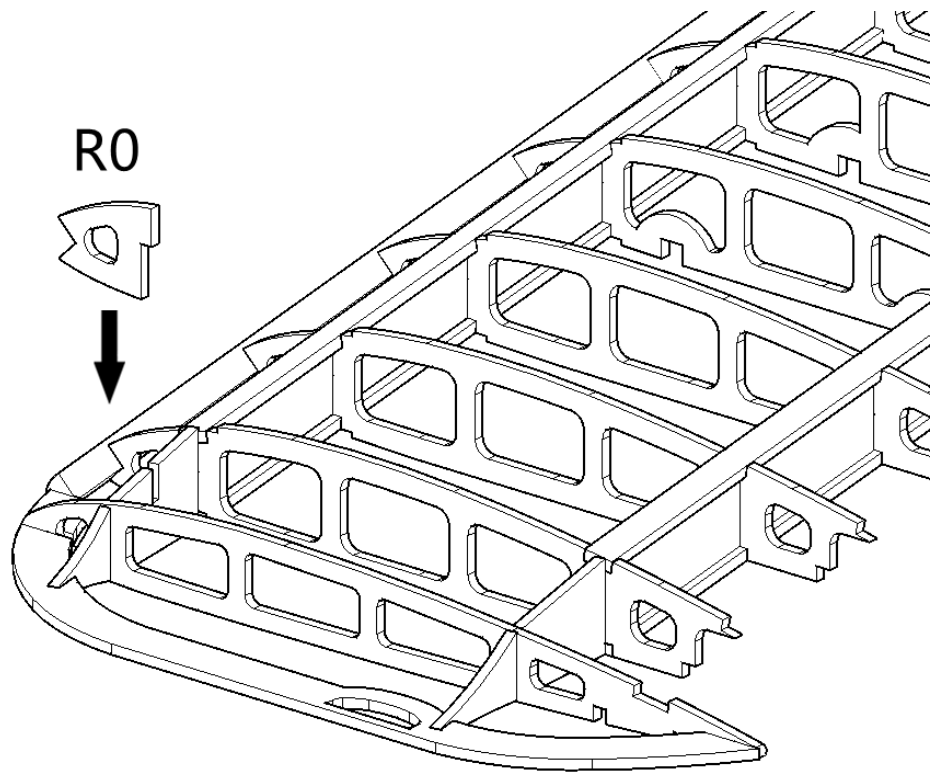

Schritt 10

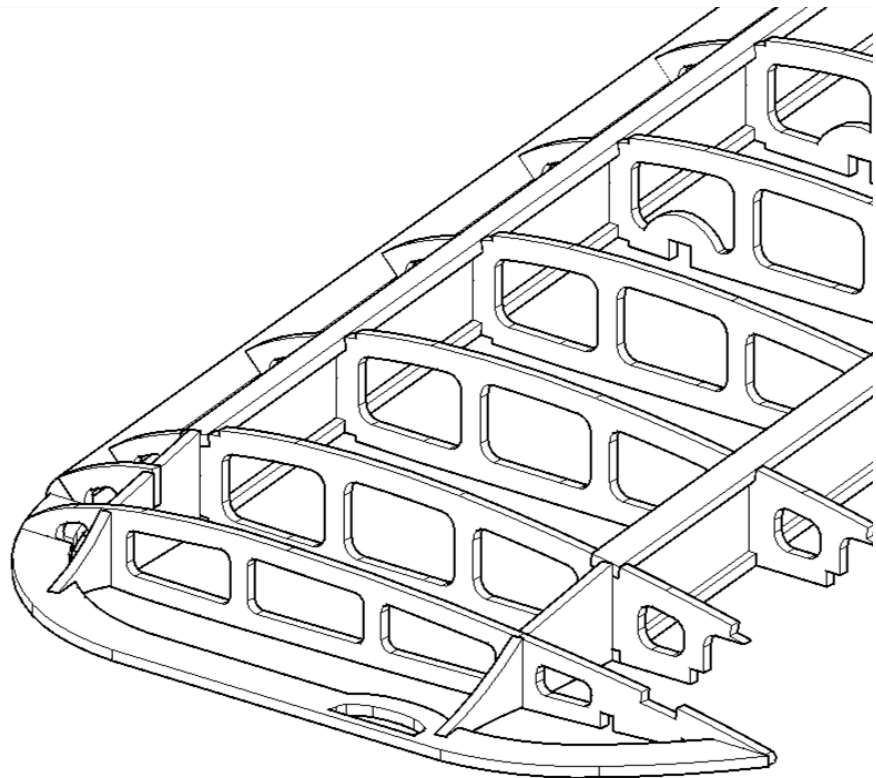

Schritt 11: 3 x 3 mm Kiefernleisten

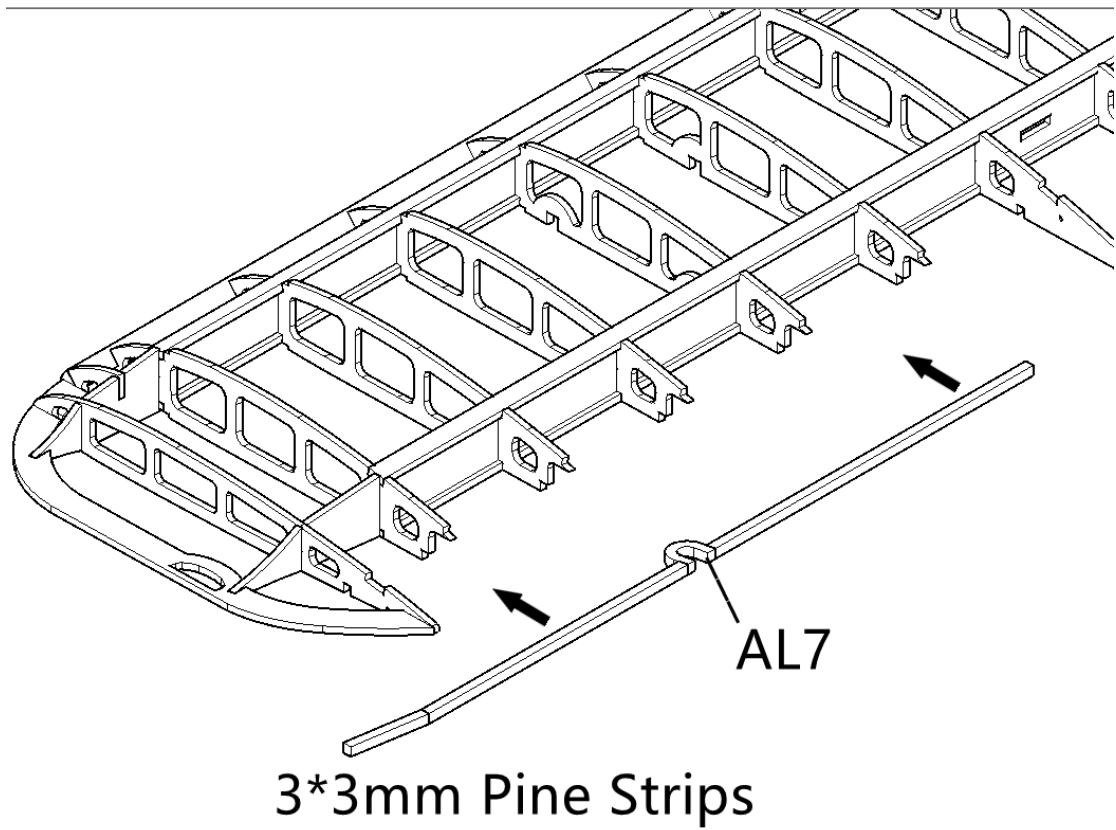

Schritt 12

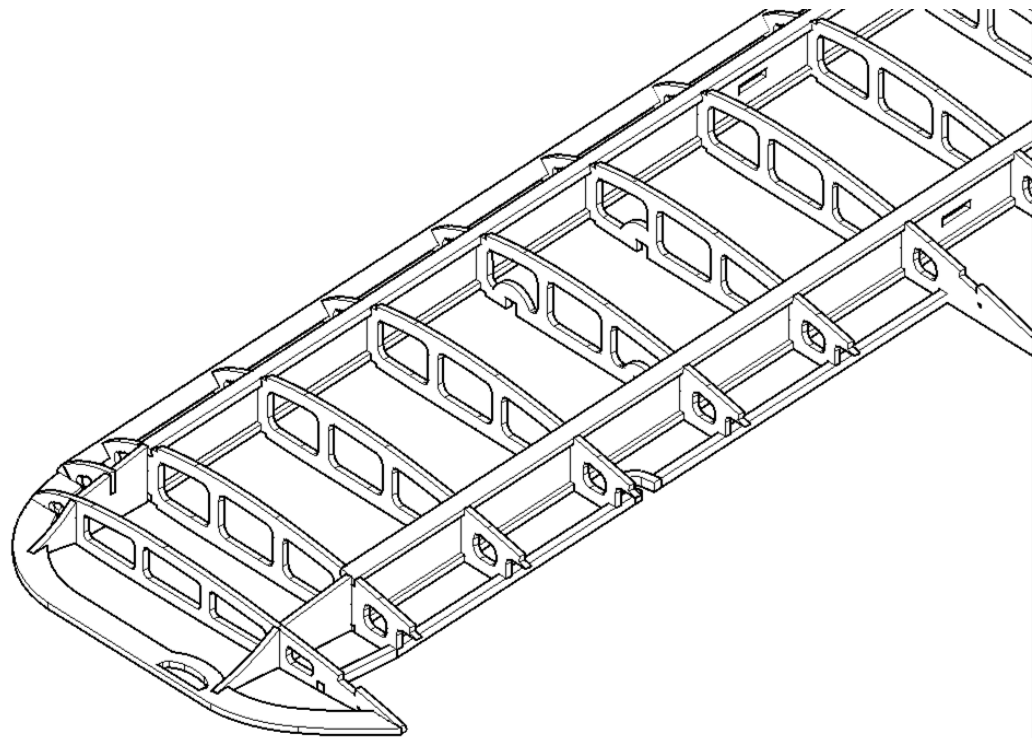

Schritt 13: 2 x 8 mm Kiefernleisten. Kante vor dem Einbau verschleifen.

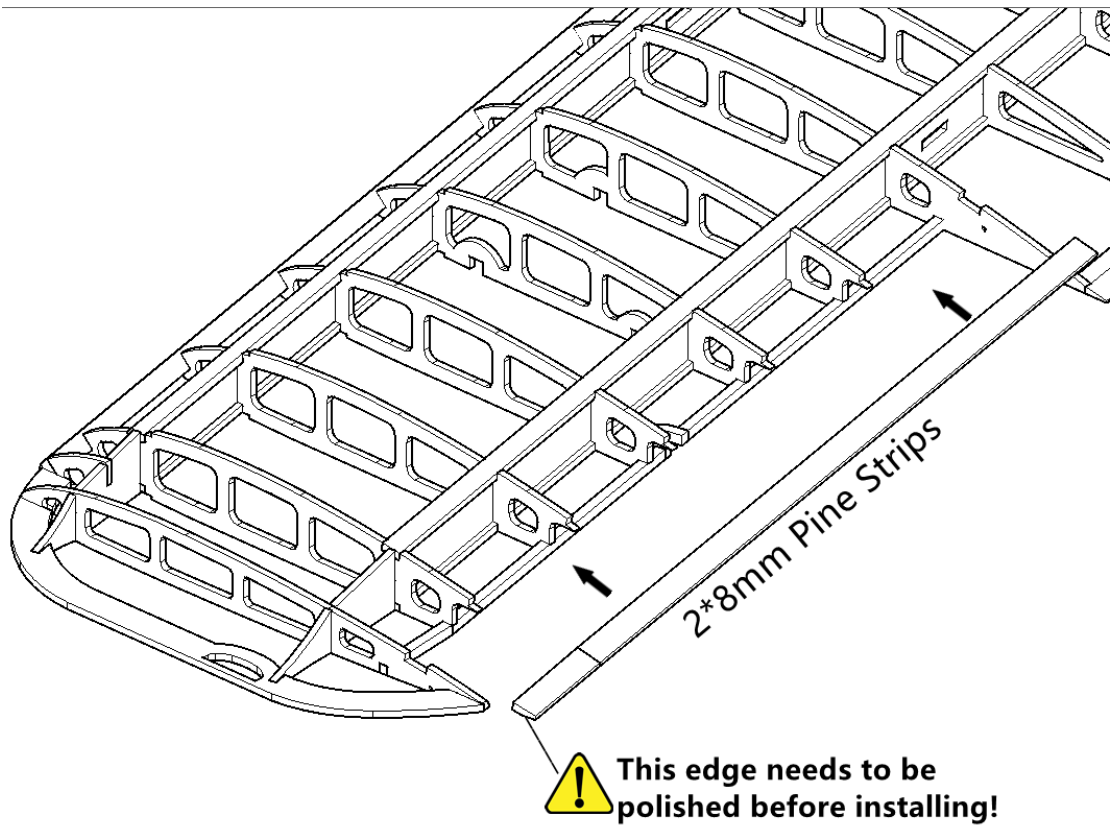

Schritt 14

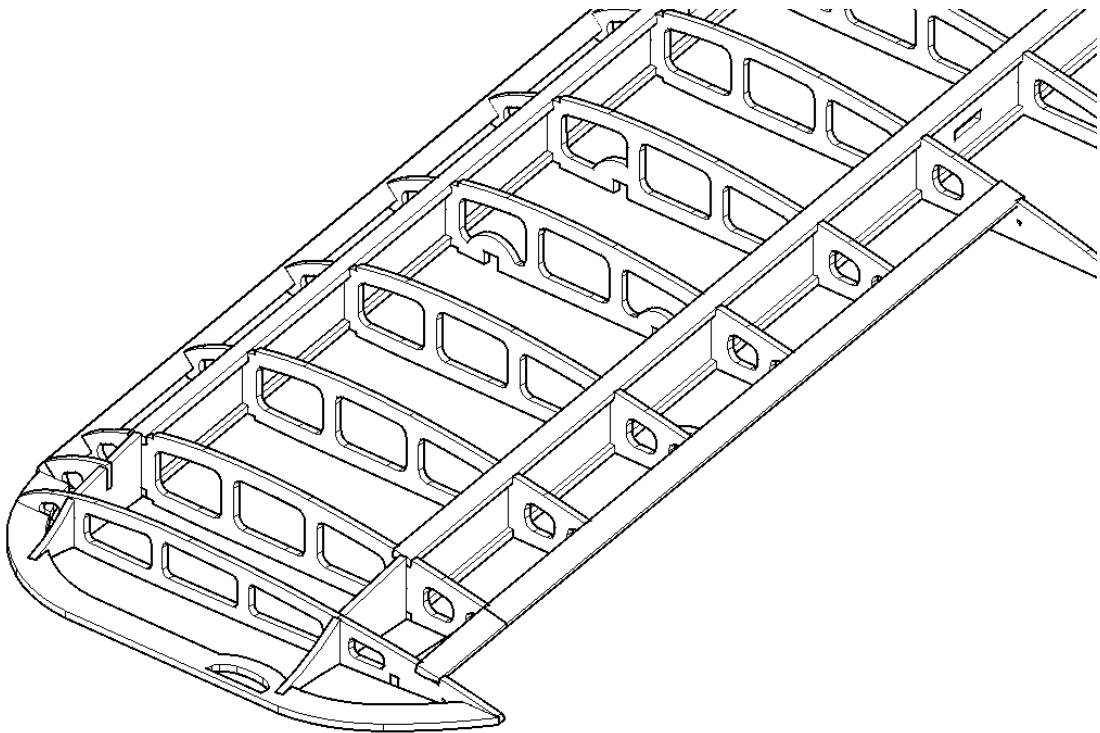

Schritt 15

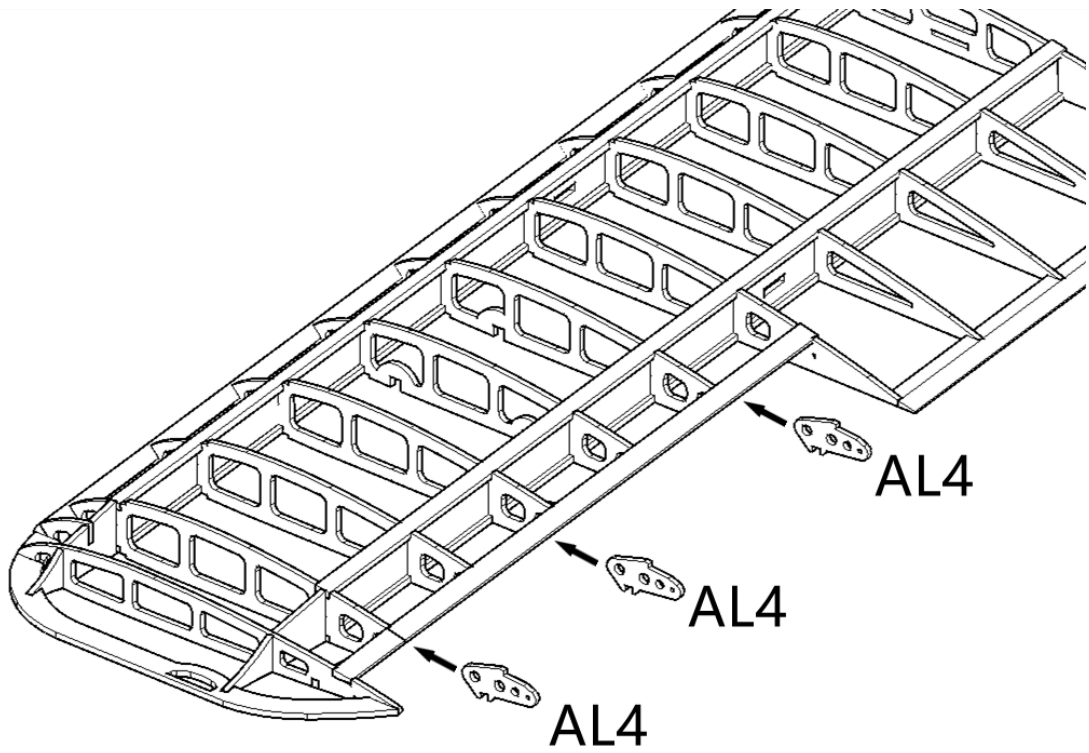

Schritt 16

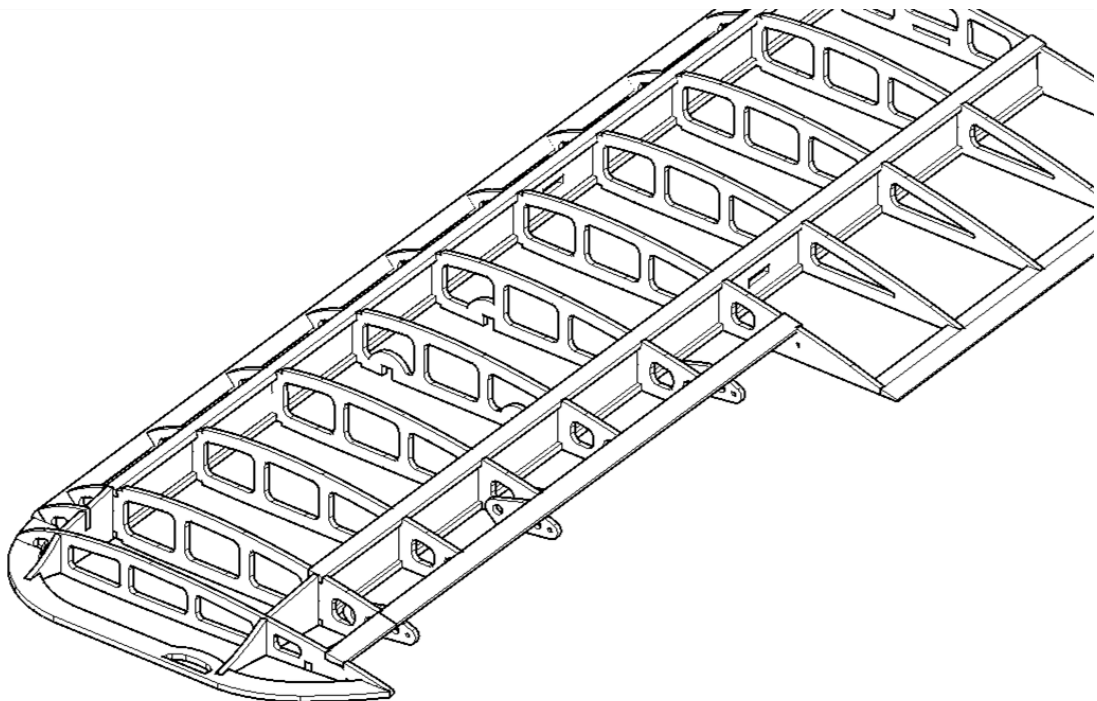

Schritt 17

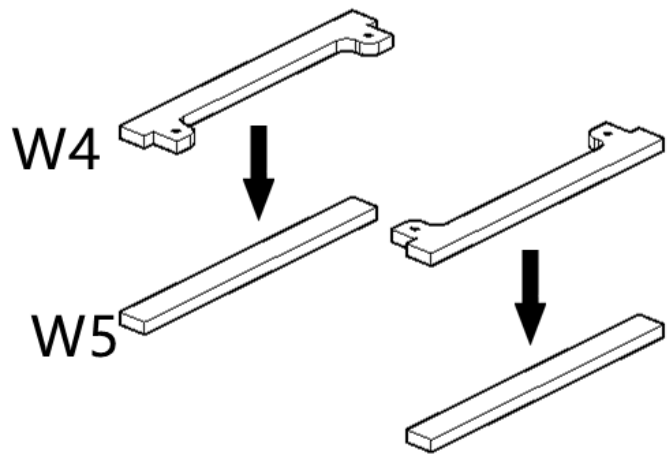

Schritt 18

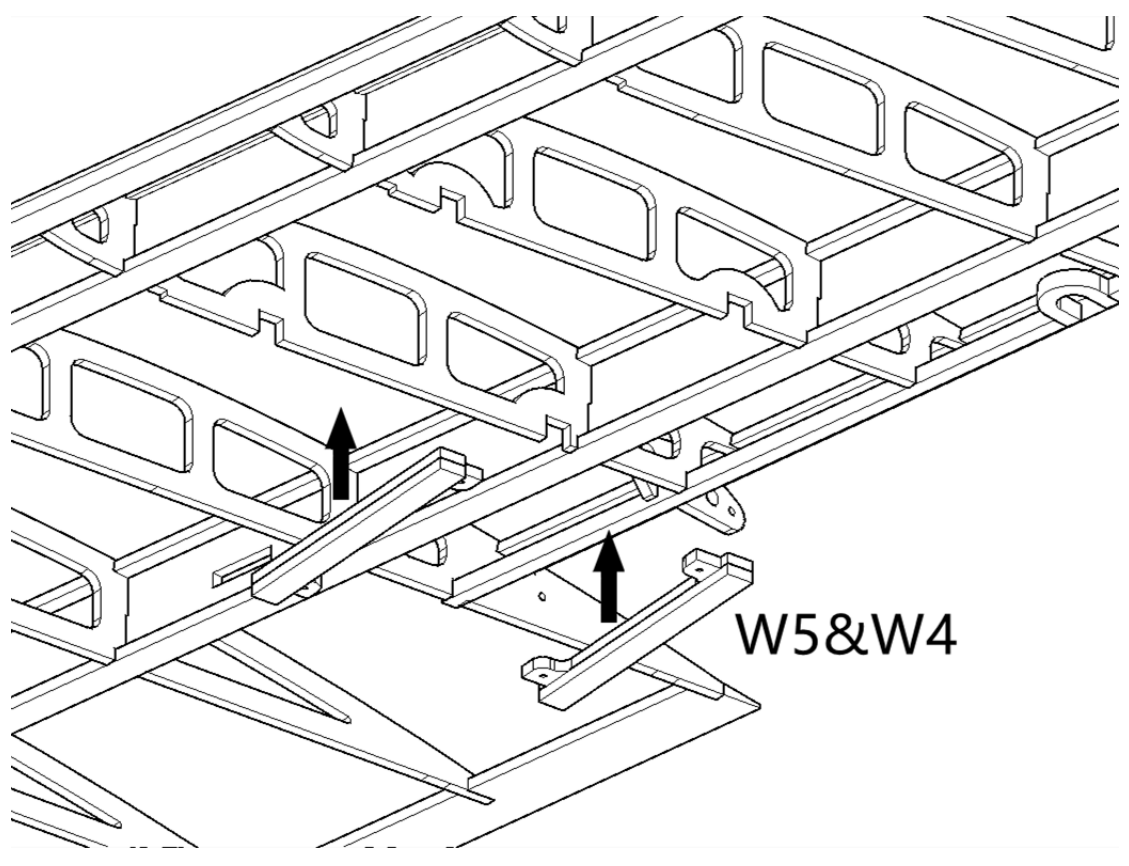

Schritt 19

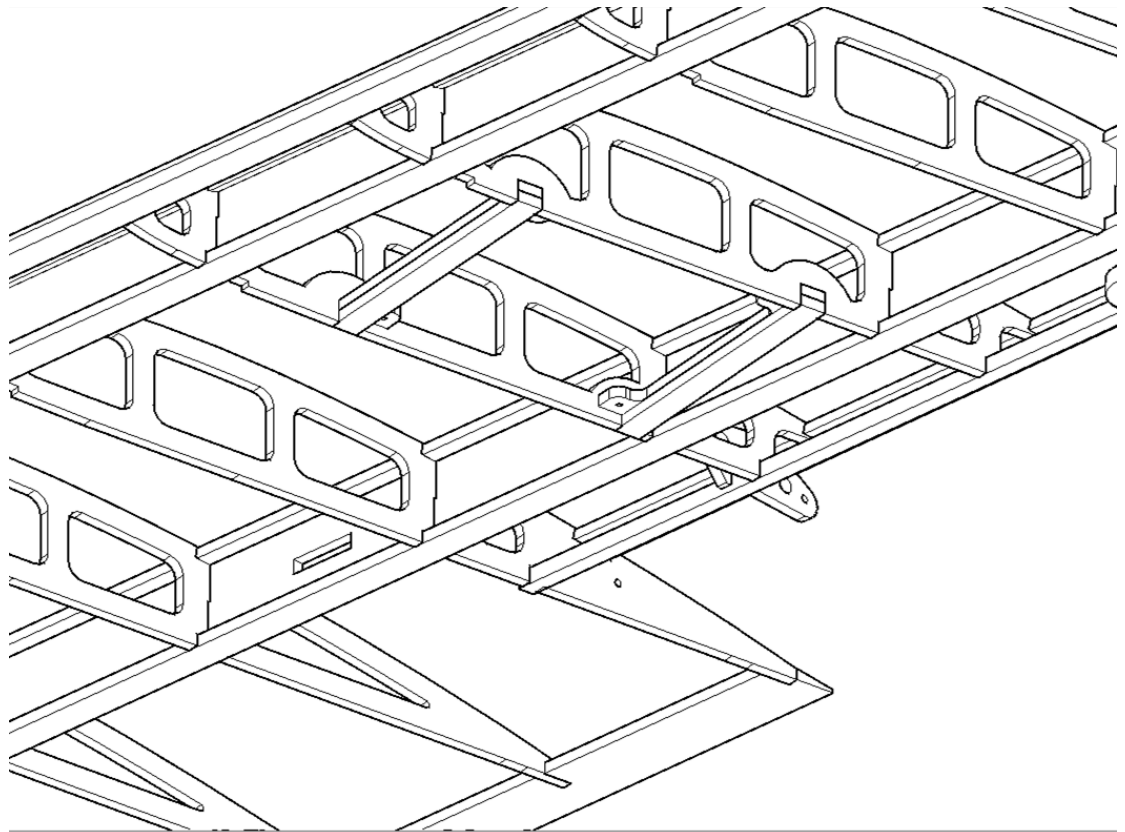

Schritt 20

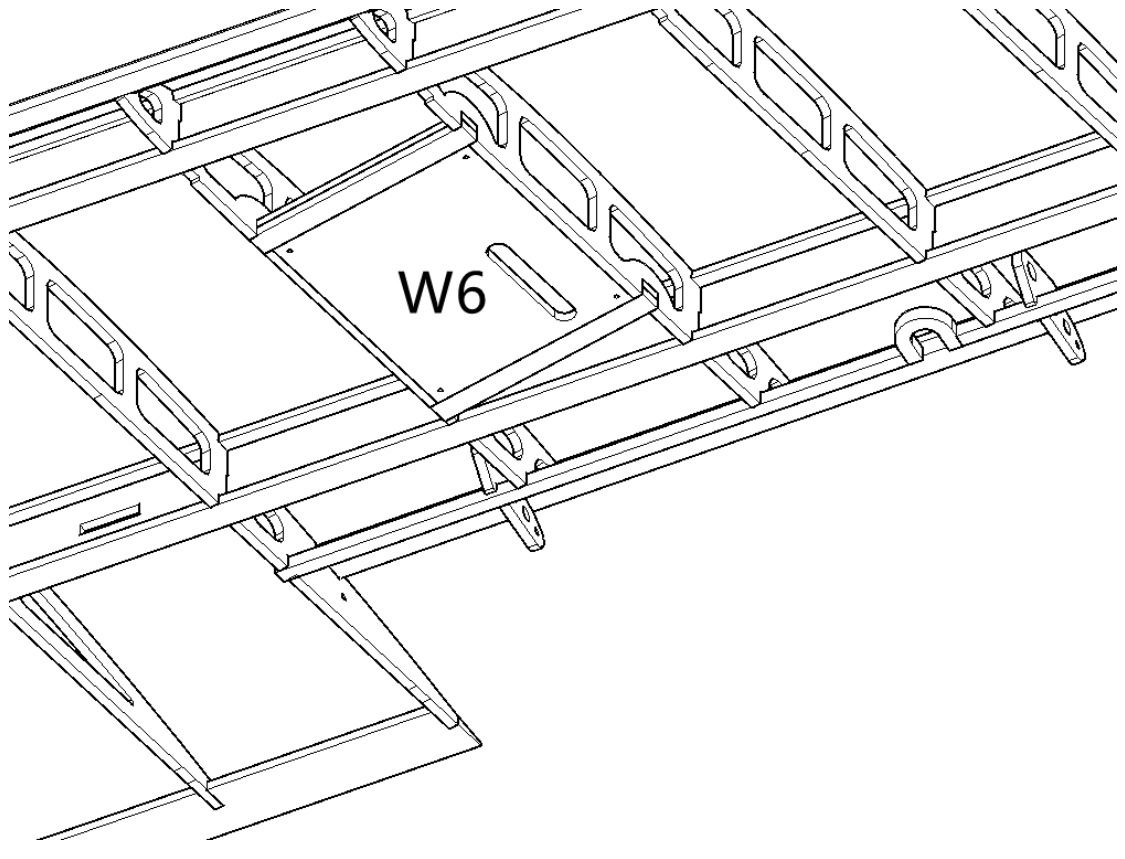

Schritt 21

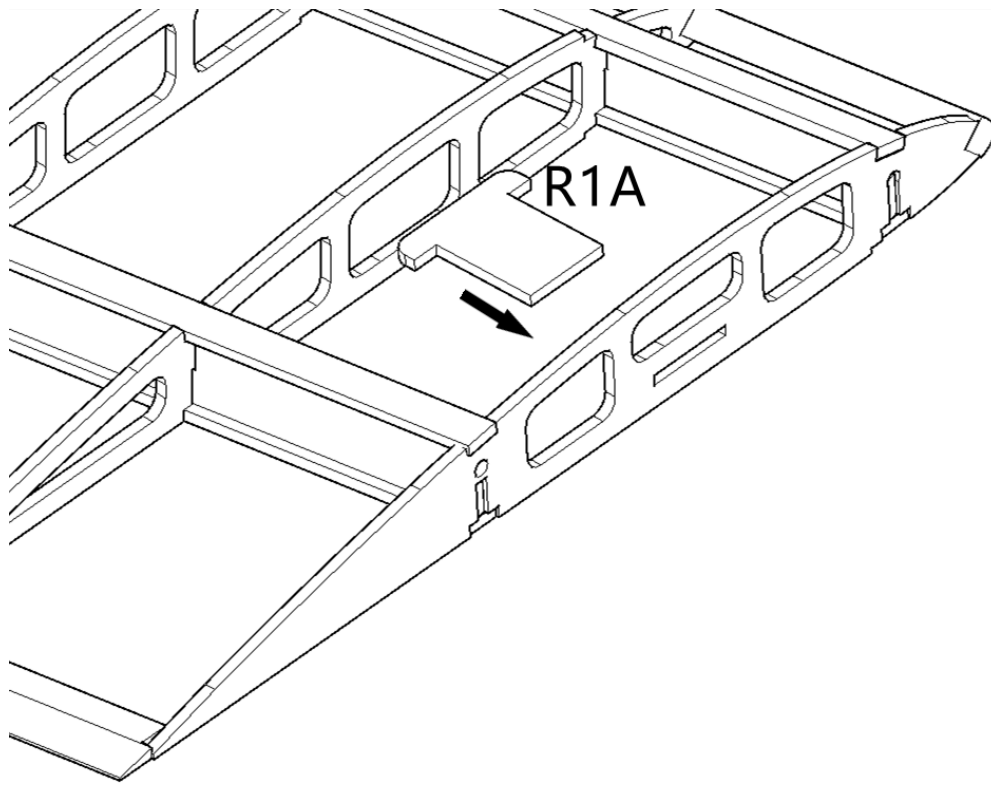

Schritt 22

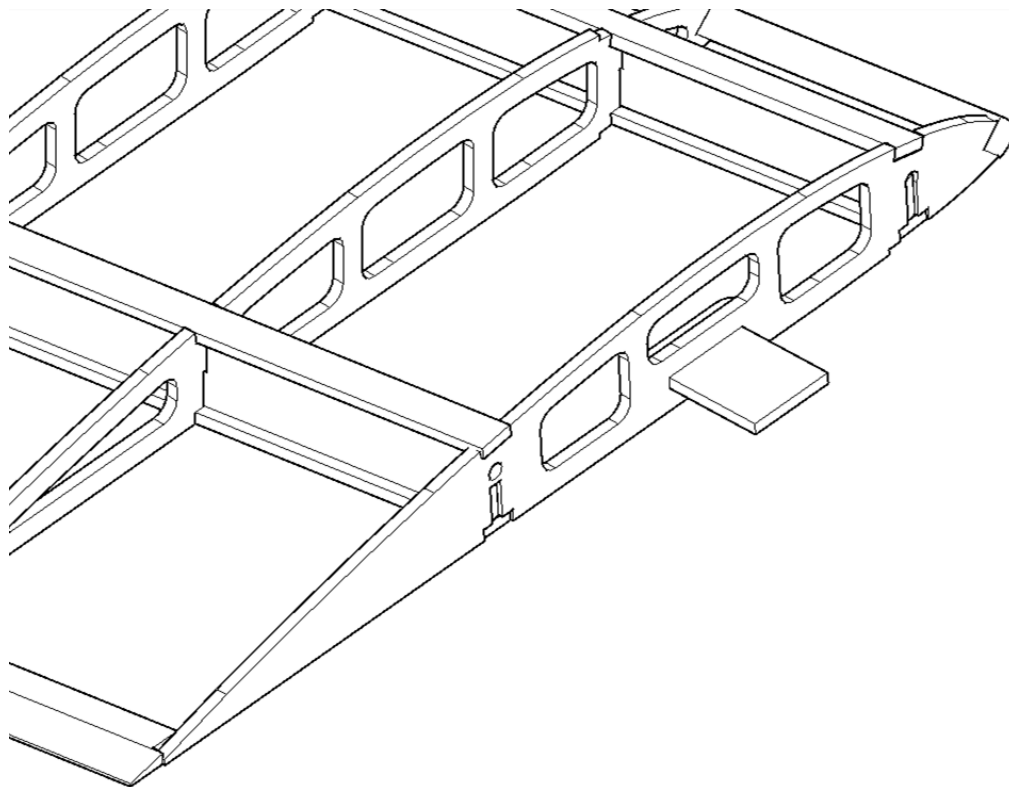

Schritt 23: 6 x 6 mm Balsa Leisten

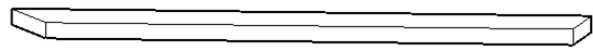
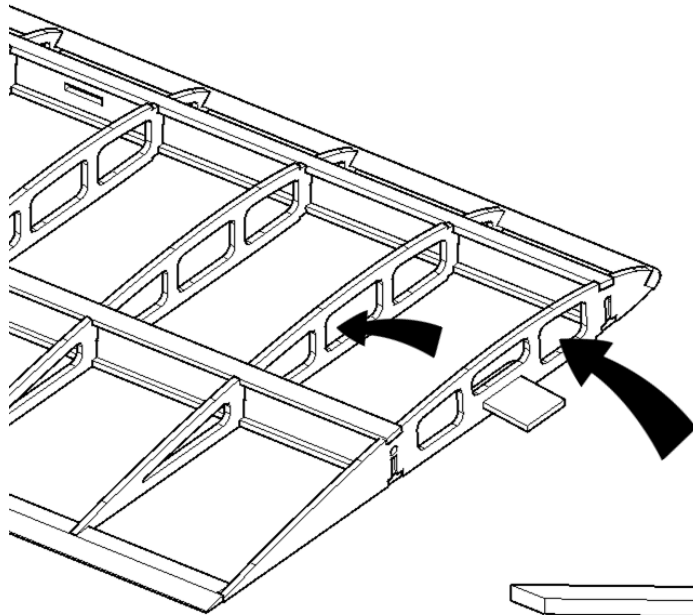

6*6mm Balsa Strips

Schritt 24

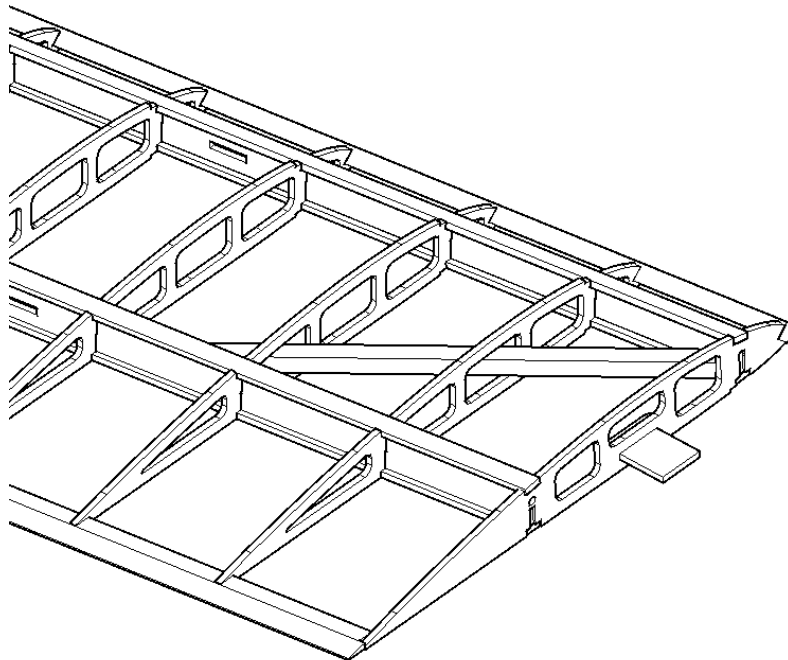

Schritt 25

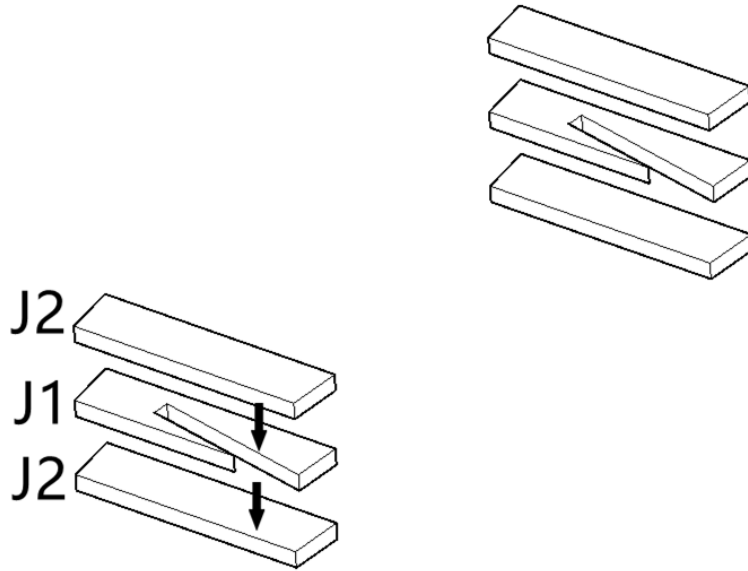

Schritt 26

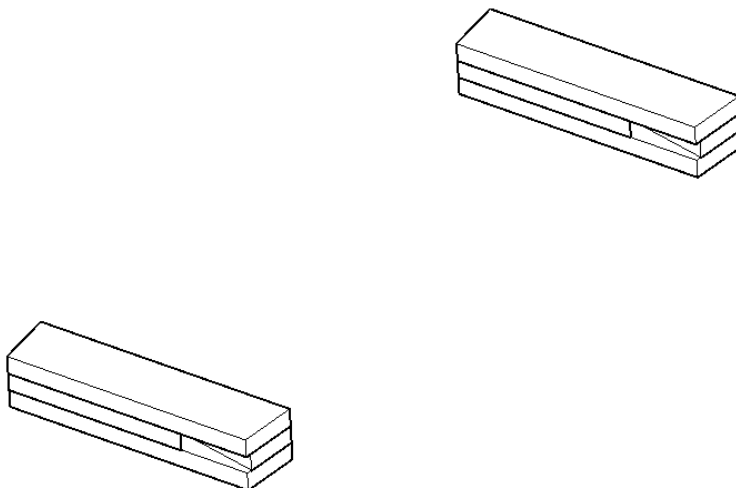

Schritt 27

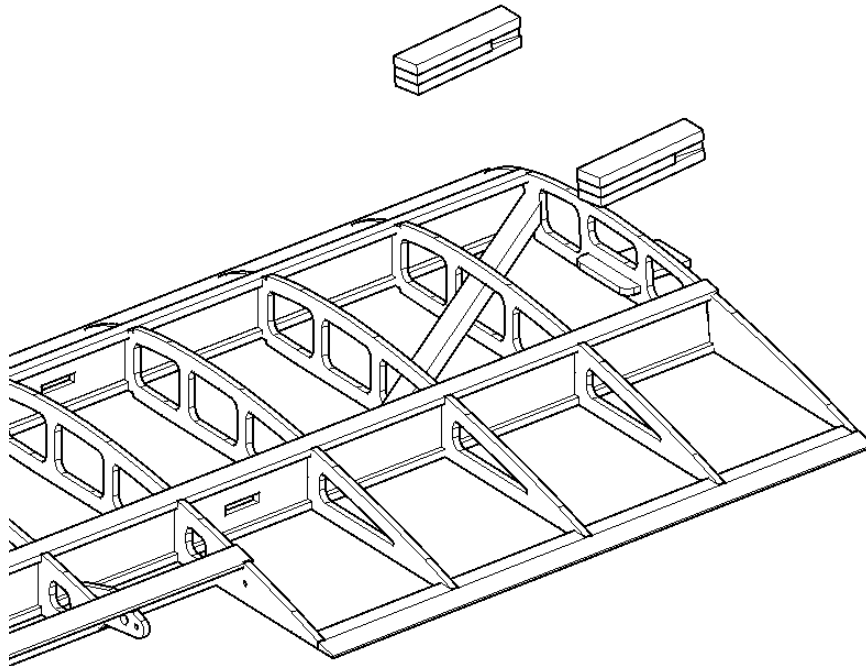

Schritt 28: Aufbohren auf 3 mm Durchmesser

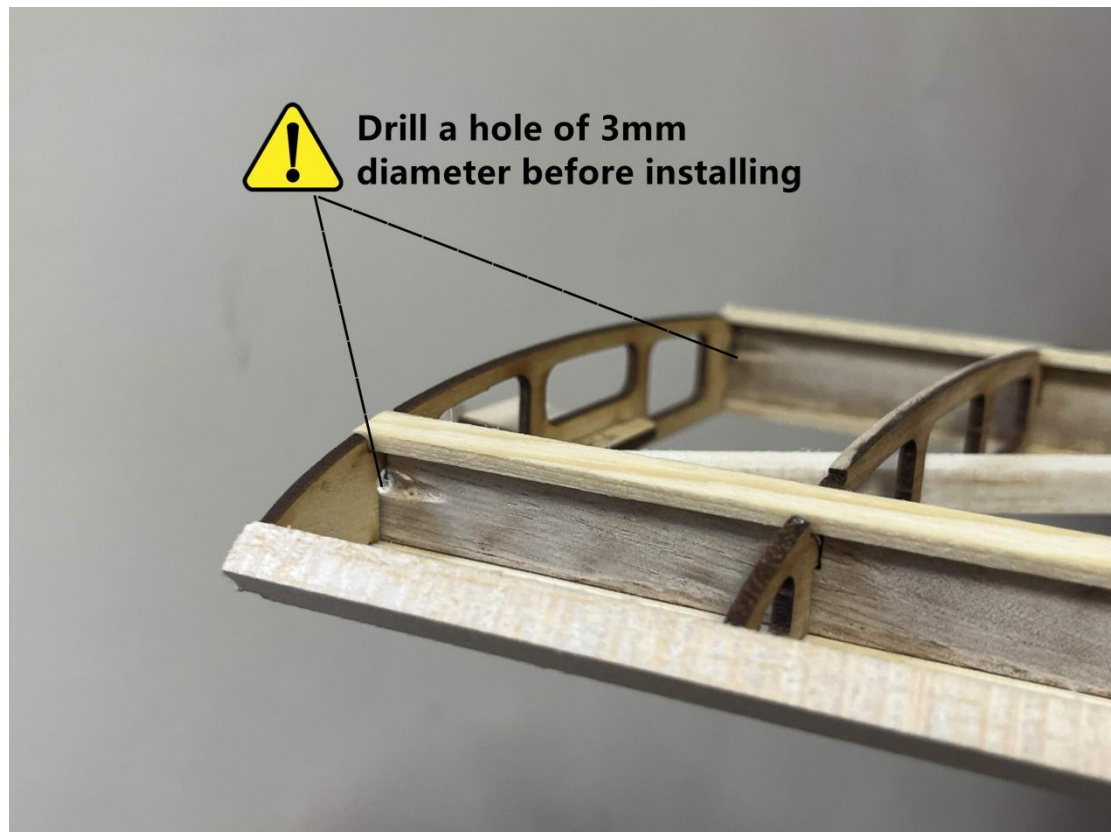

Schritt 29: M3 x 30 Gewindestange. M3 Hutmutter.

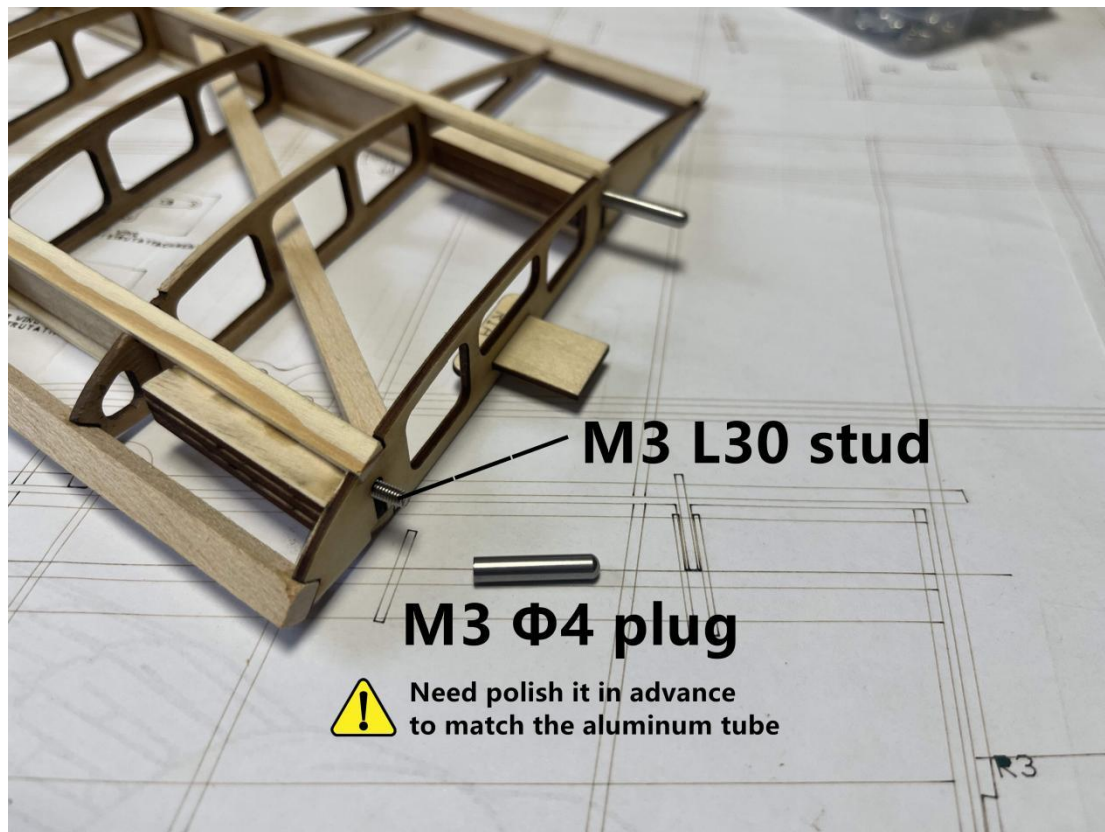

Schritt 30: Durch vorsichtiges Schleifen, Durchmesser der Hutmutter anpassen.

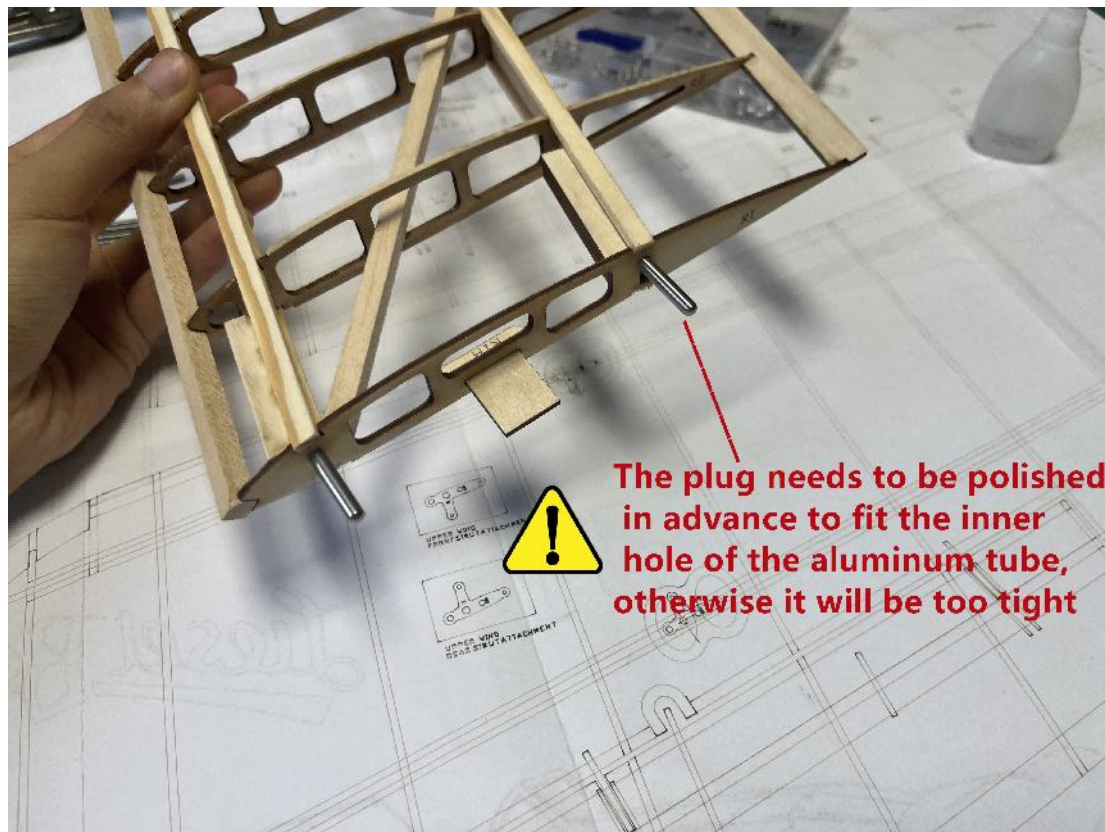

Schritt 31

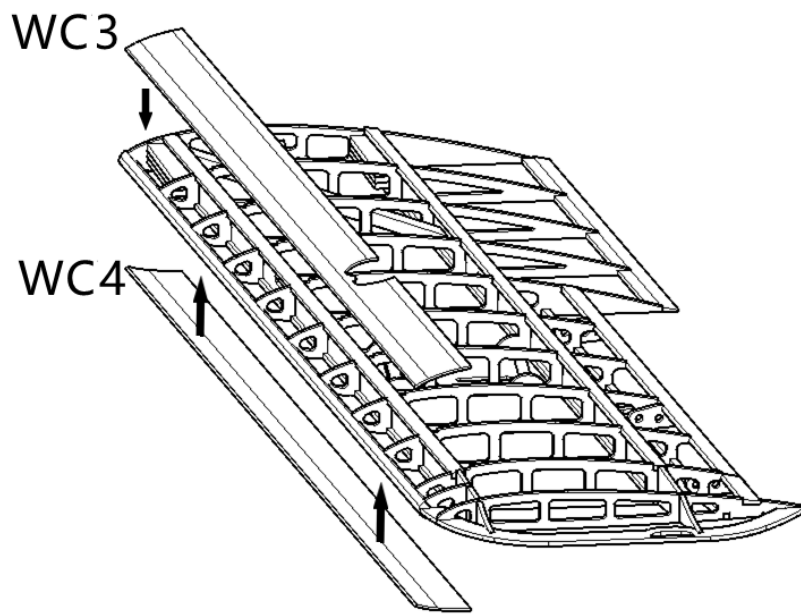

Schritt 32

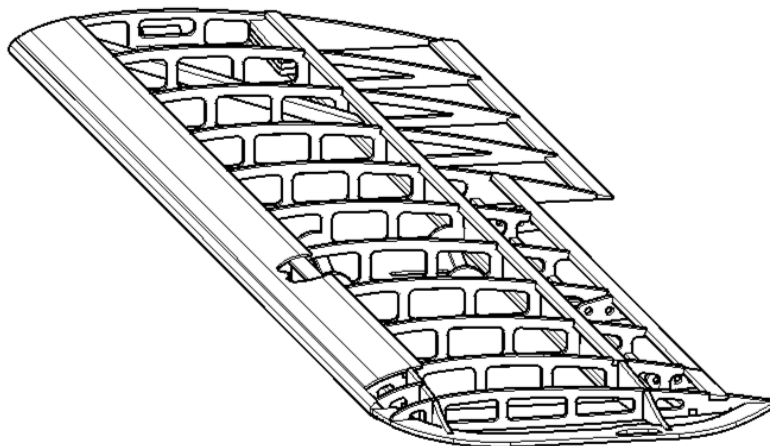

Schritt 33

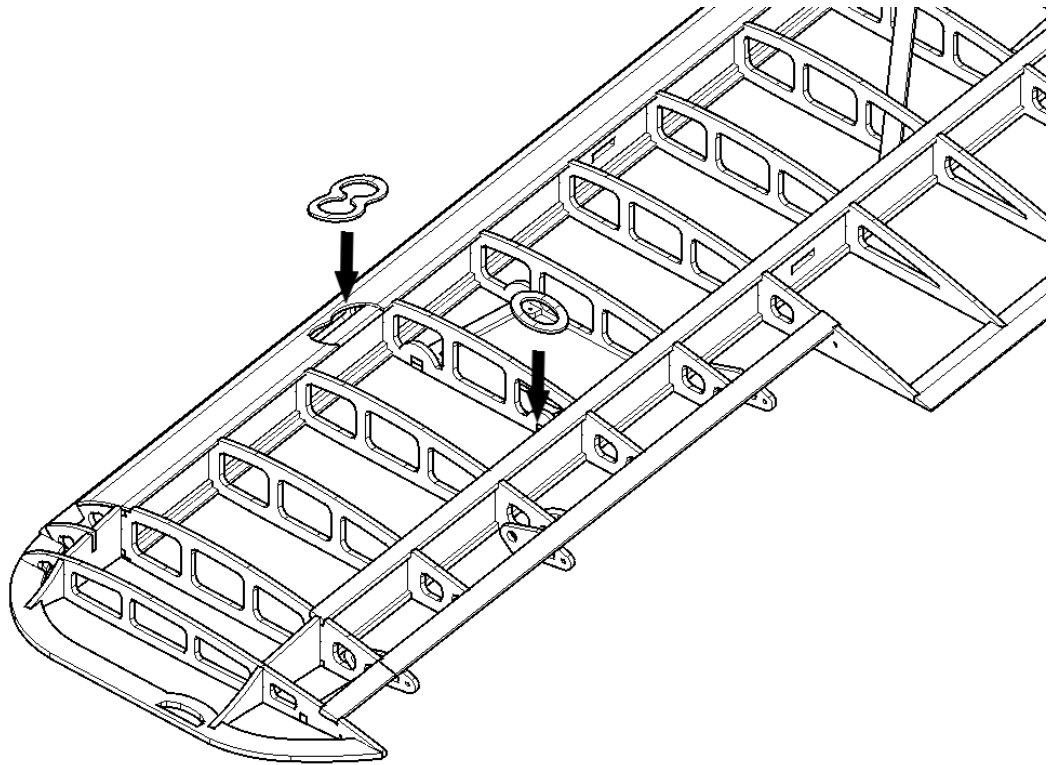

Schritt 34

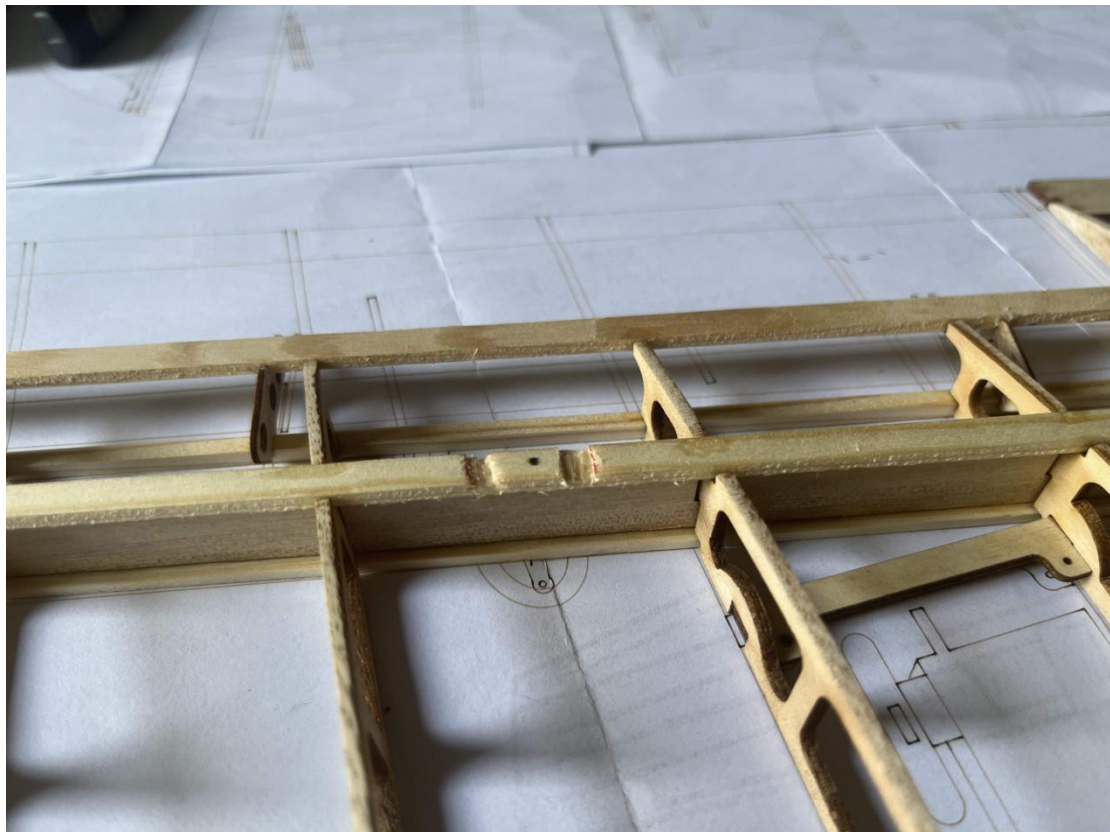

Schritt 35: Die runde Öffnung mittig über dem Kiefernholm ausrichten.

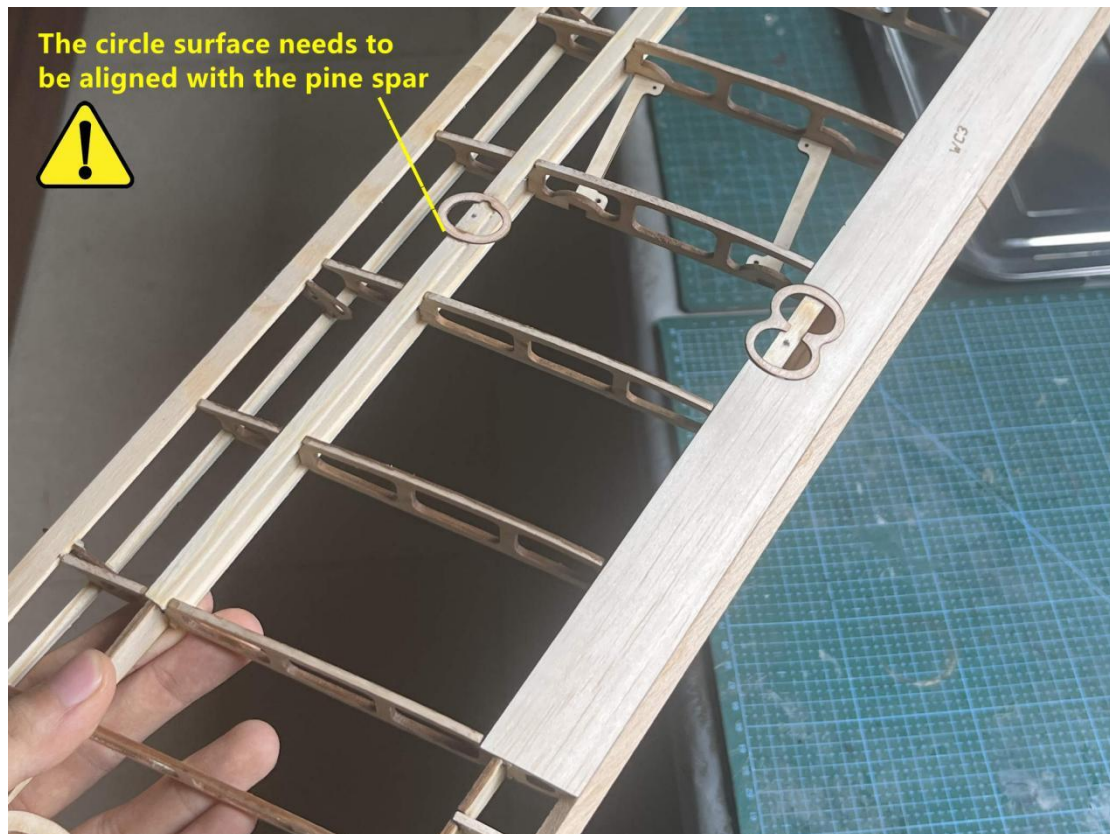

Schritt 36: 1 mm tief anpassen.



Schritt 37

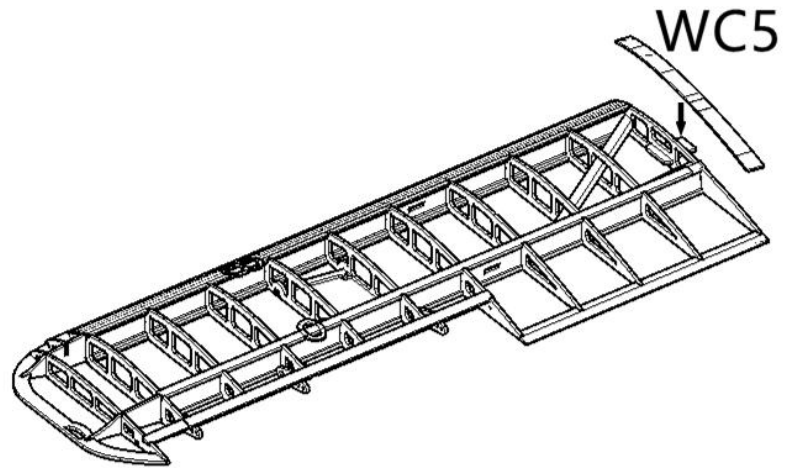

Schritt 38

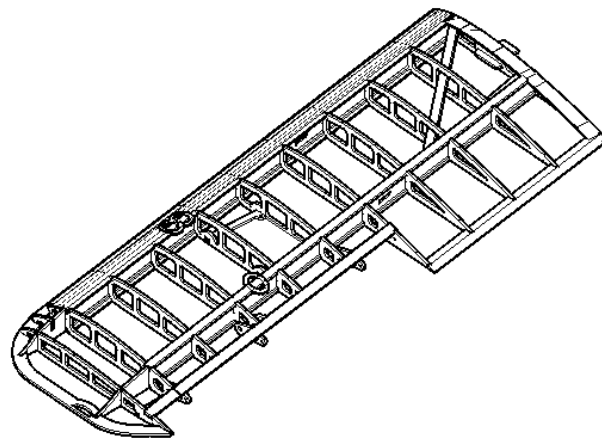

Schritt 39

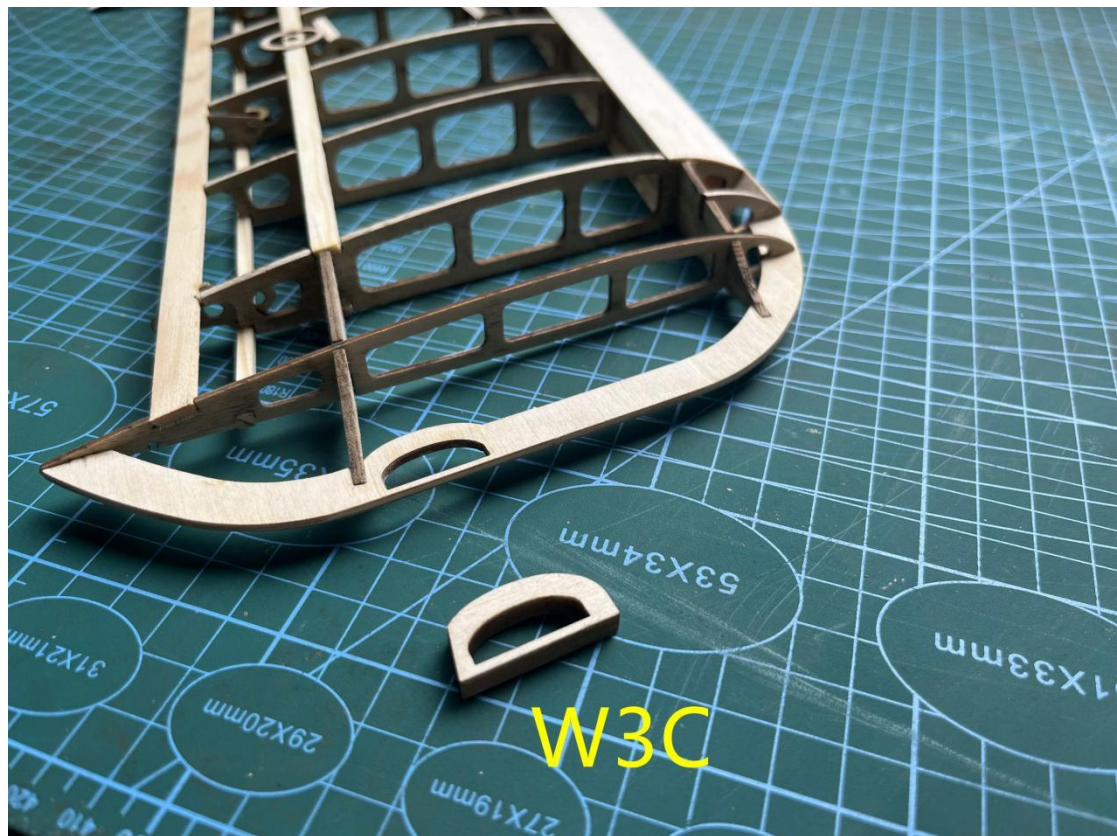

Schritt 40

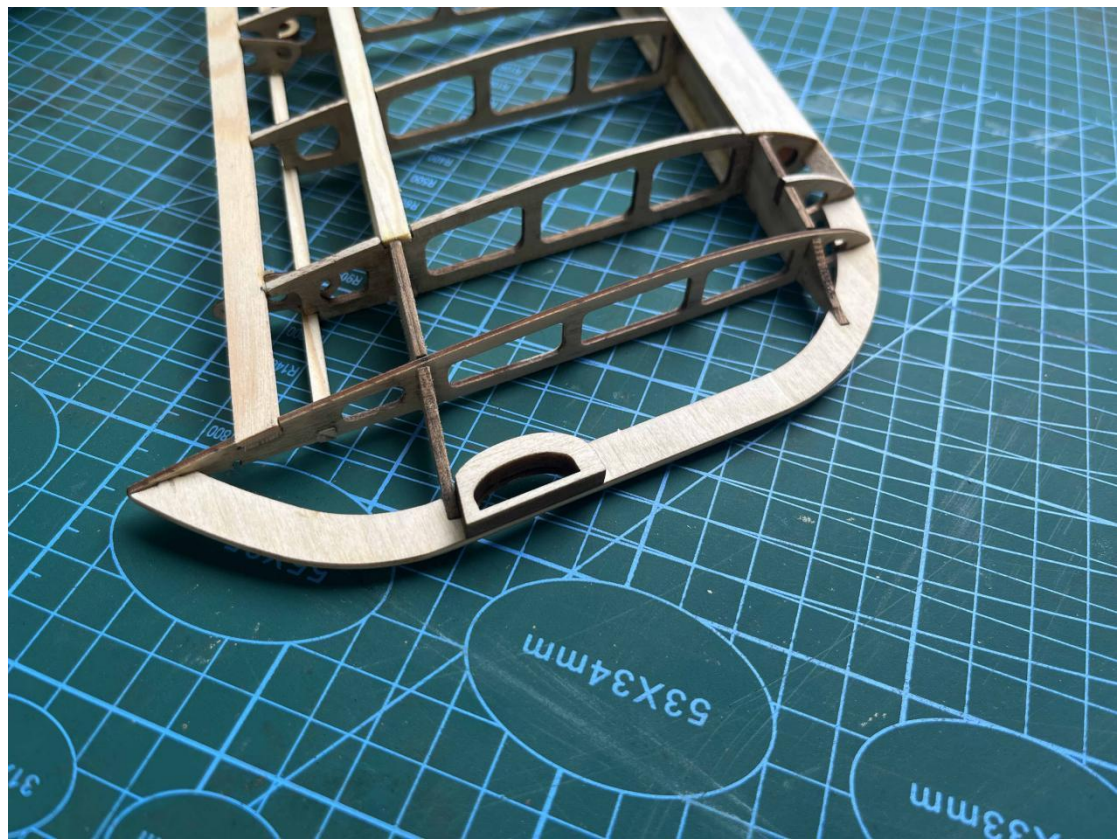

Schritt 41: Zur Rippe hin anschrägen.

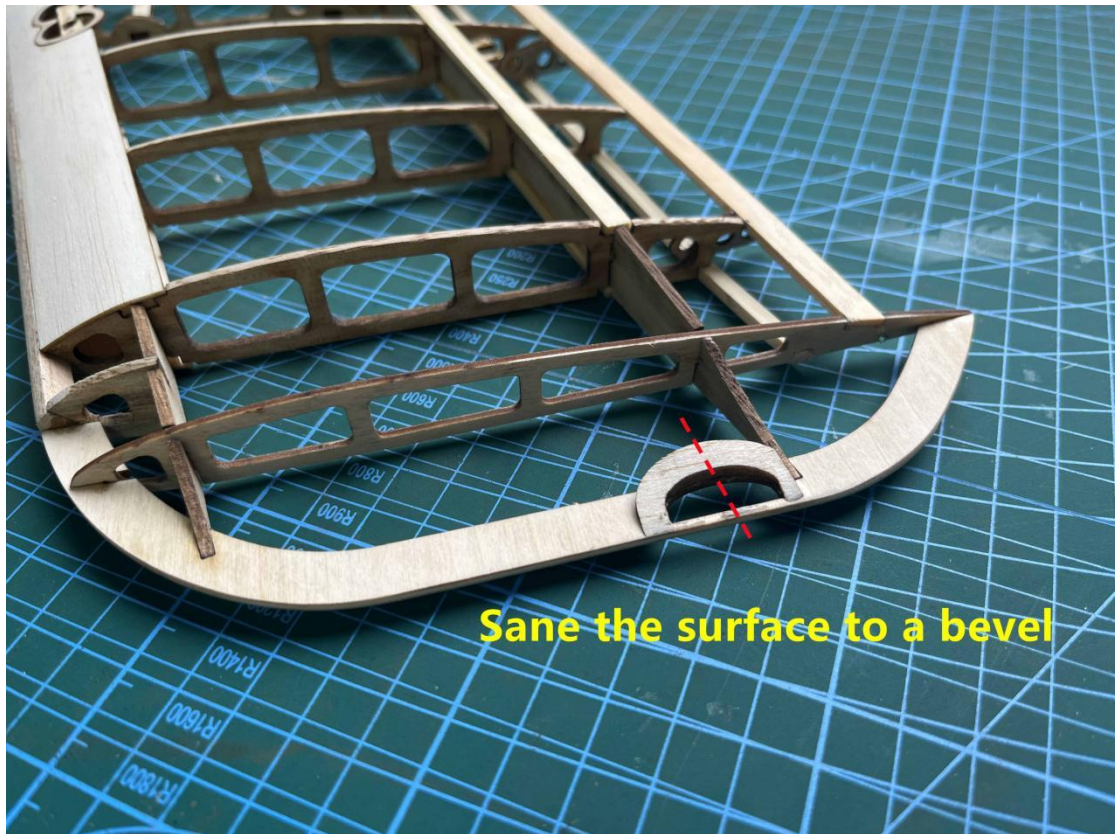

Eigene Notizen:

8. Montage – Obere Tragfläche

Schritt 1: 2 x 6 mm Kiefernleisten

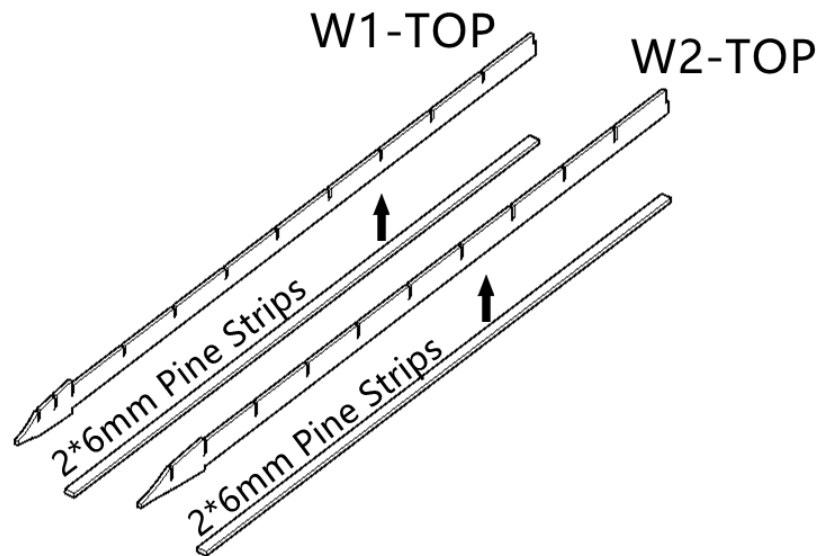

Schritt 2

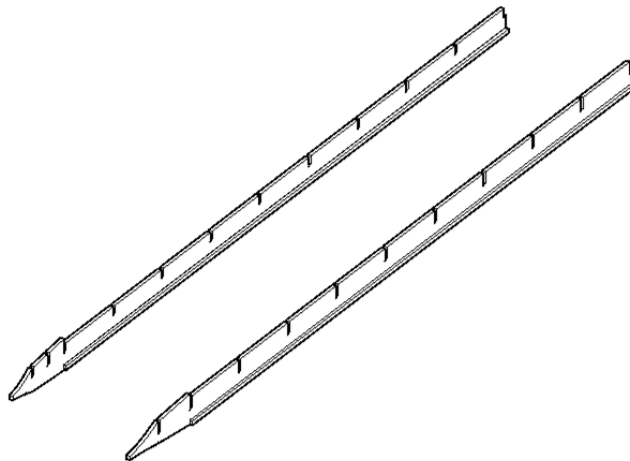

Schritt 3

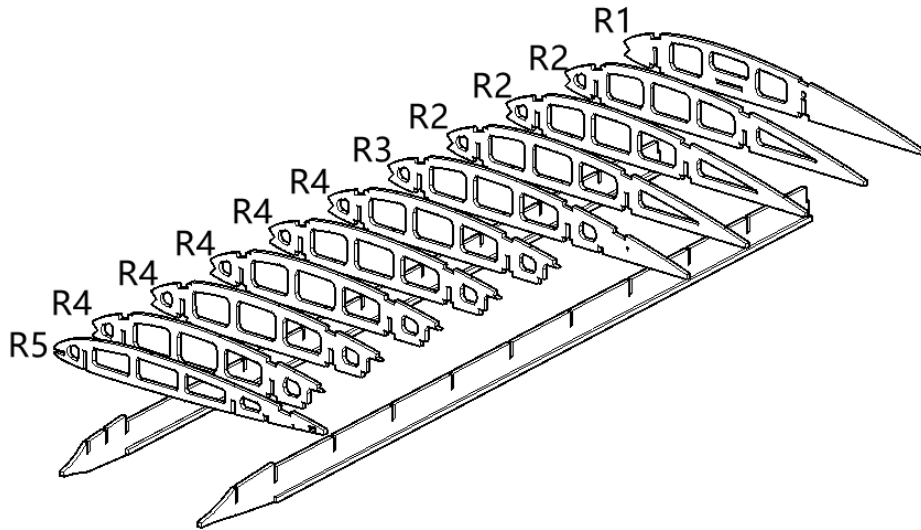

Schritt 4

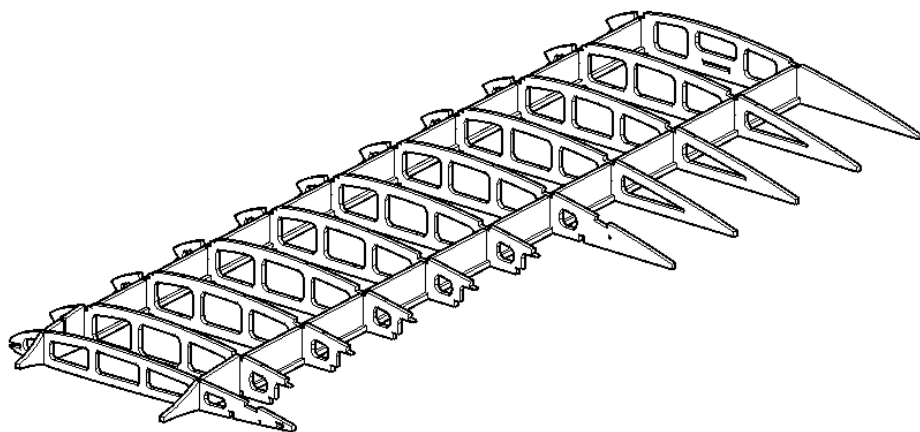

Schritt 5: 6 x 6 mm Balsa Leisten

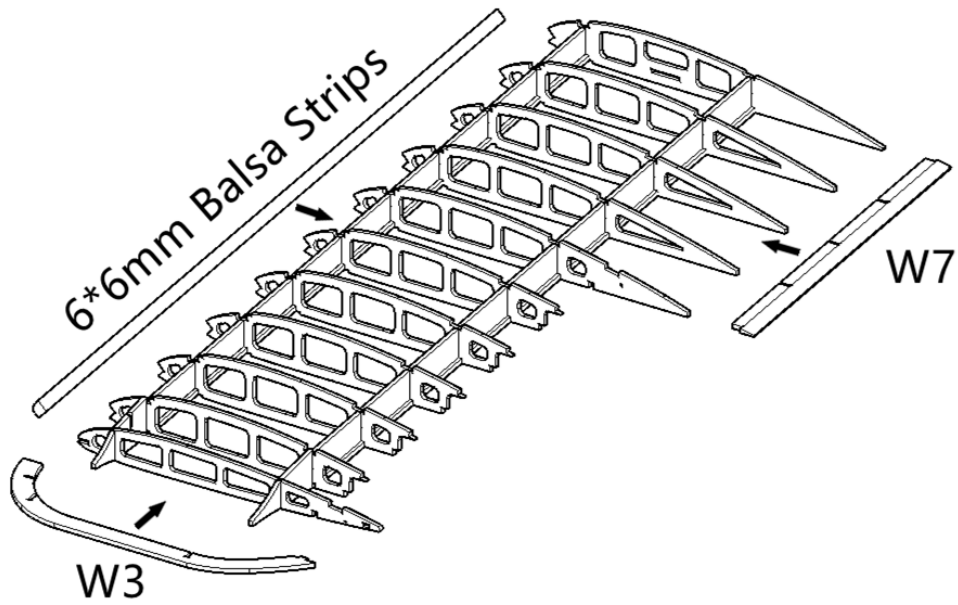

Schritt 6

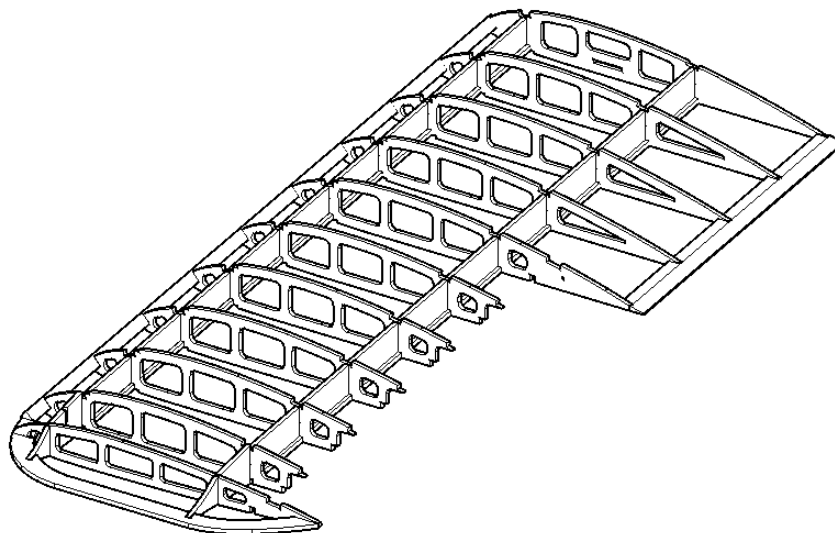

Schritt 7: 6 x 2 mm Kiefernleisten

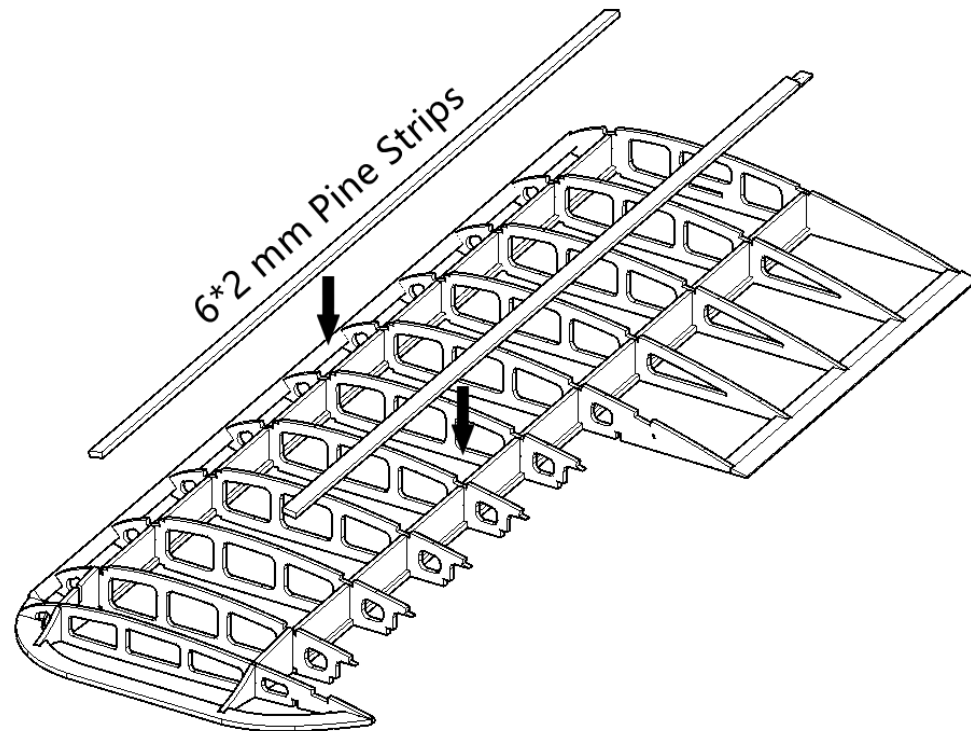

Schritt 8

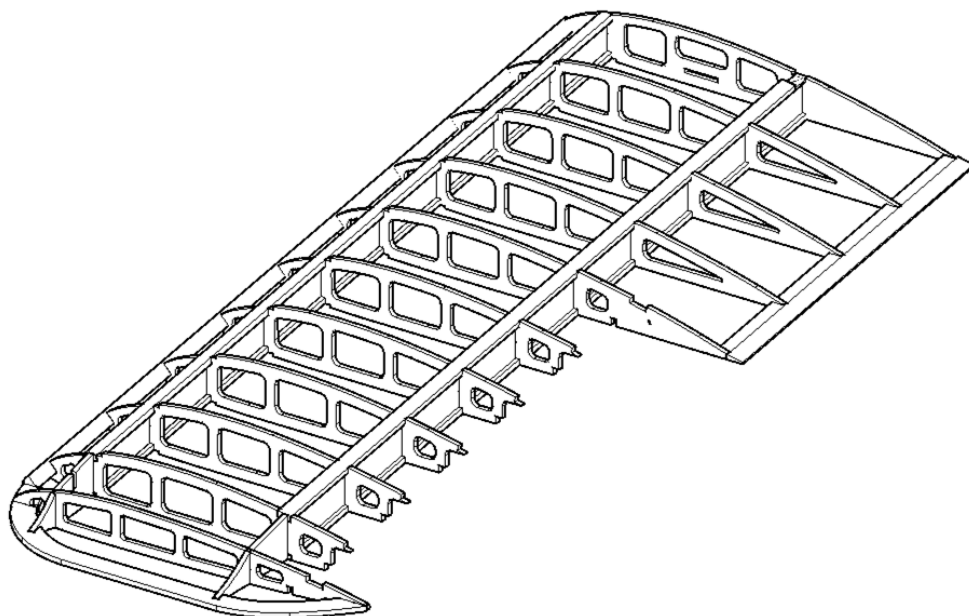

Schritt 9

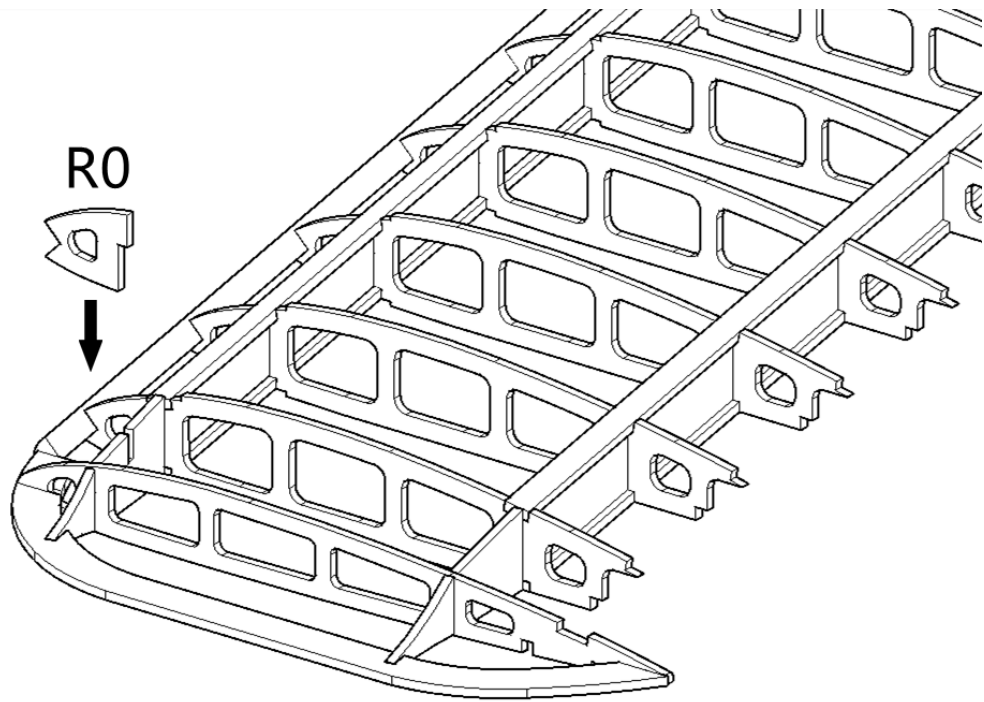

Schritt 10

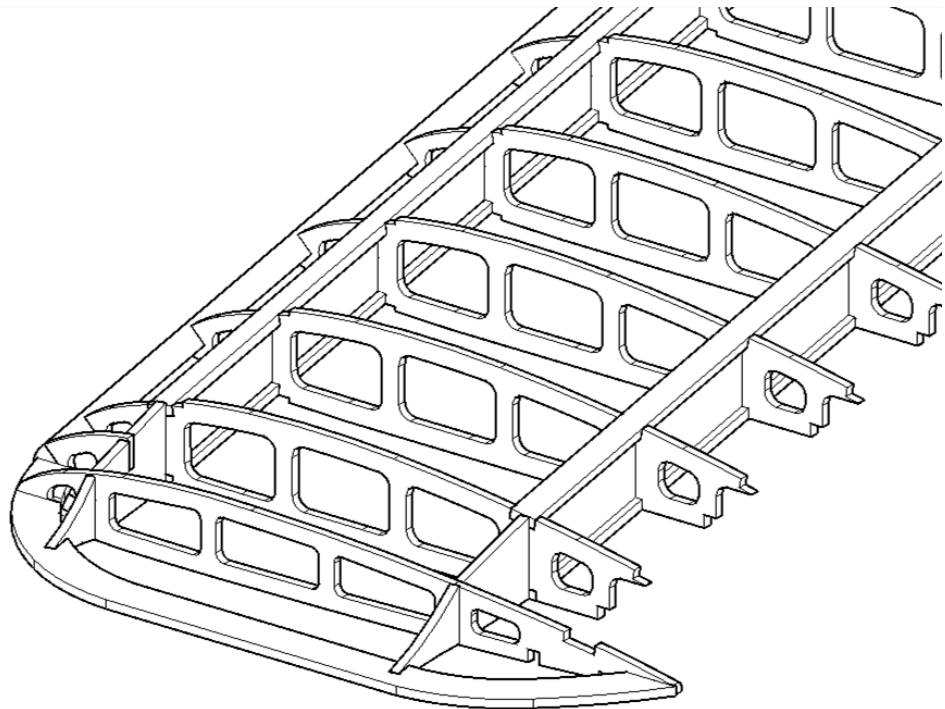

Schritt 11: 3 x 3 mm Kiefernleisten

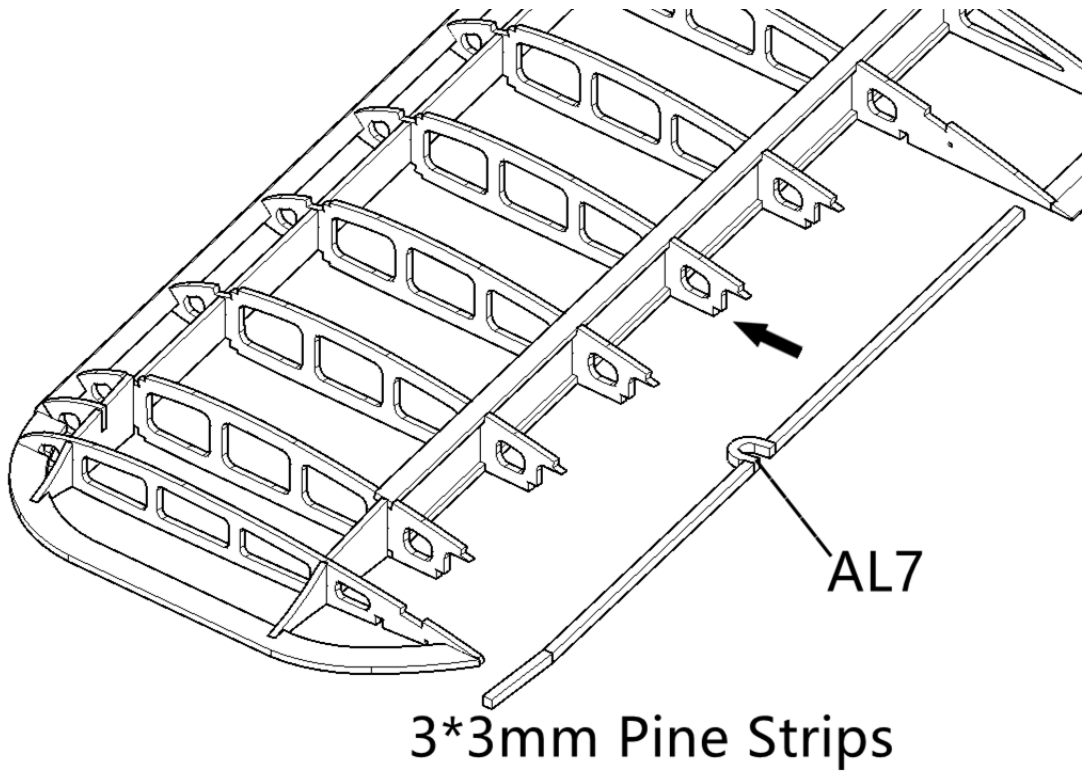

Schritt 12

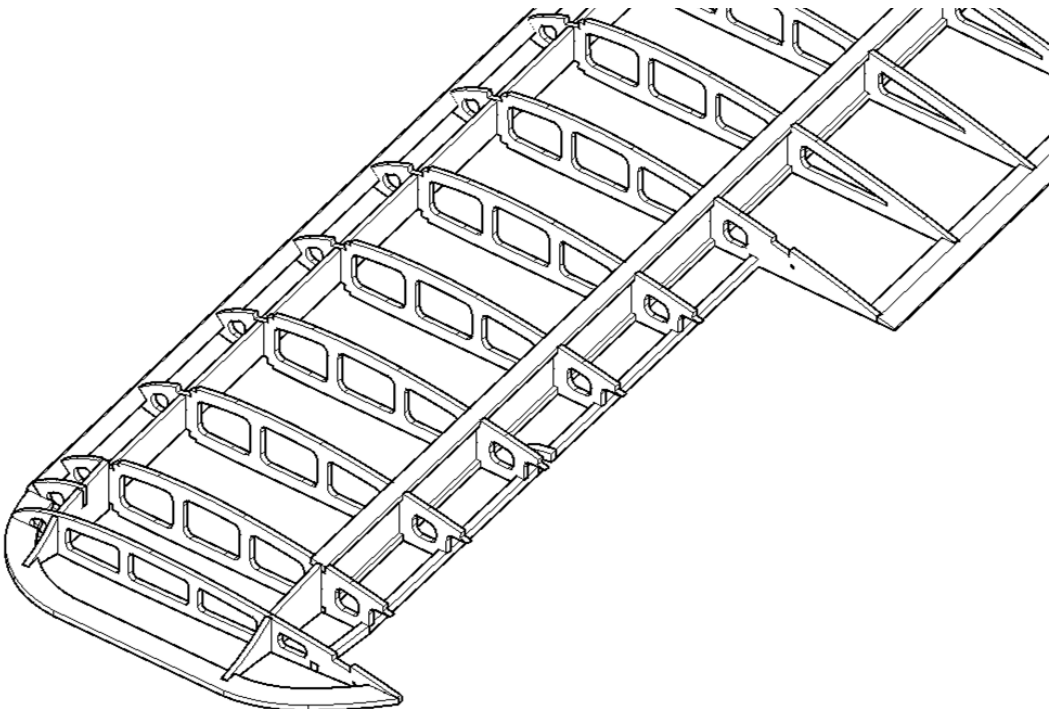

Schritt 13: 2 x 8 mm Kiefernleisten. Kanten vor dem Einbau verschleifen

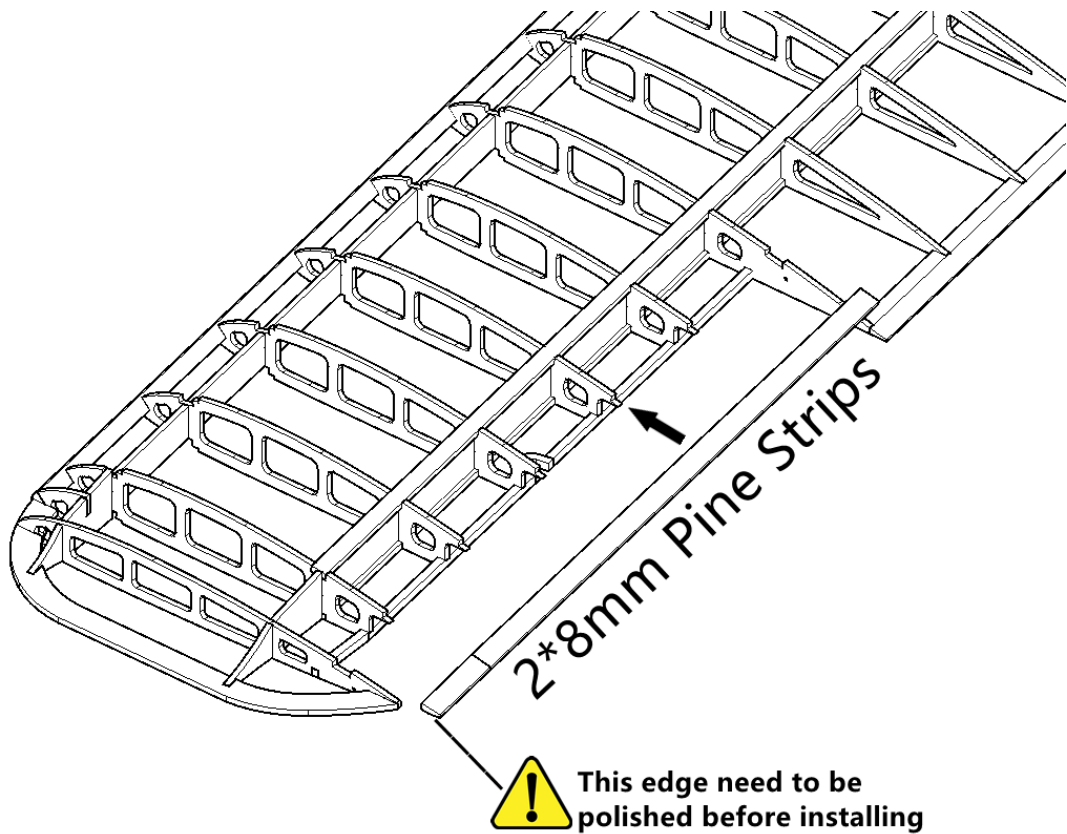

Schritt 14

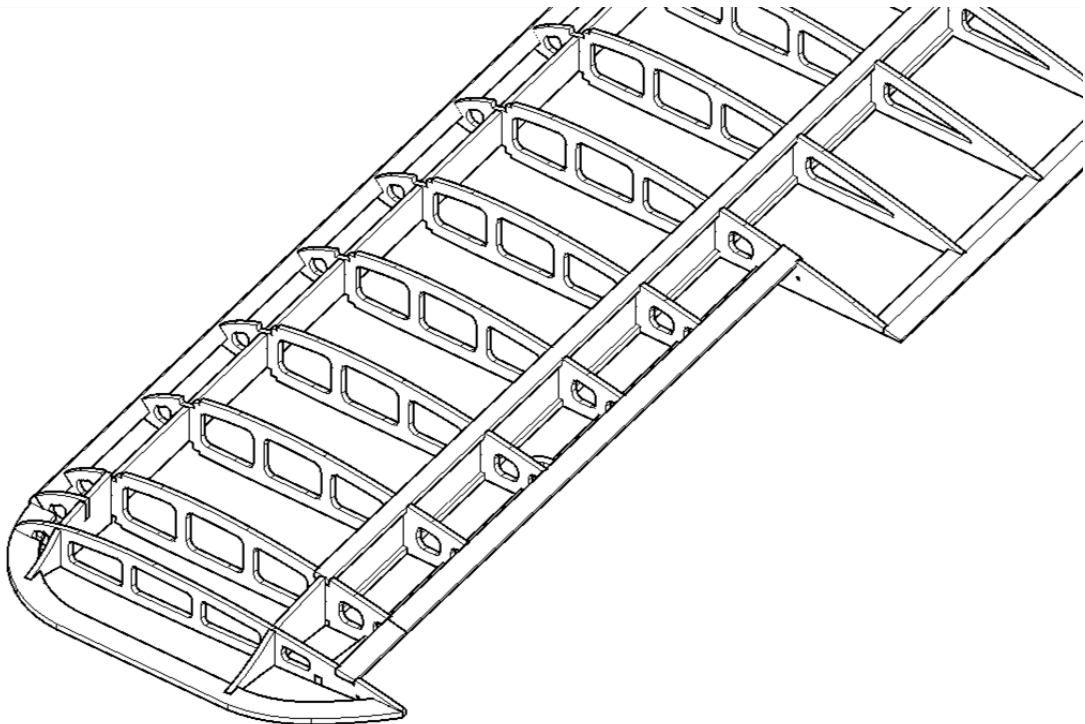

Schritt 15

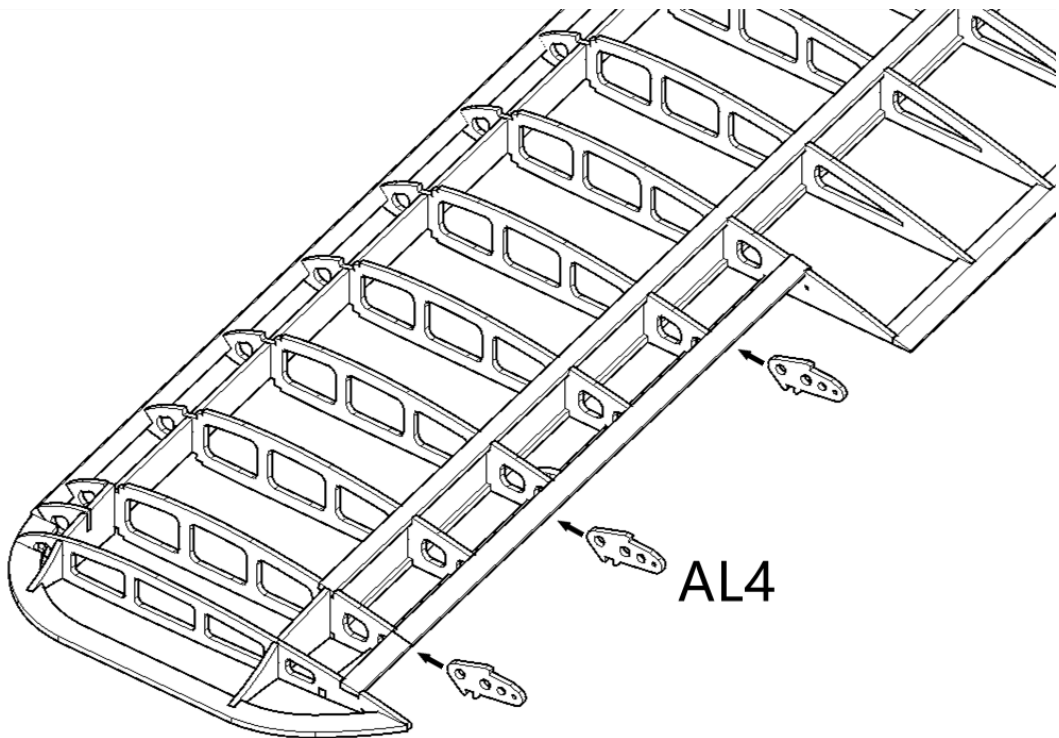

Schritt 16

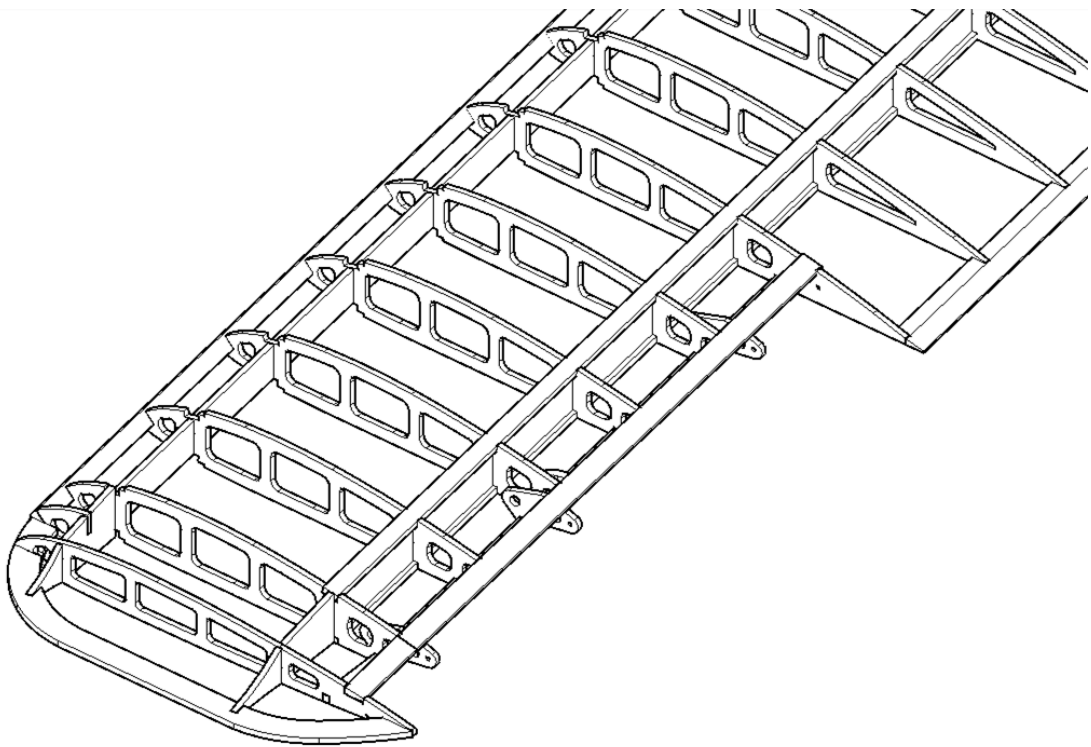

Schritt 17

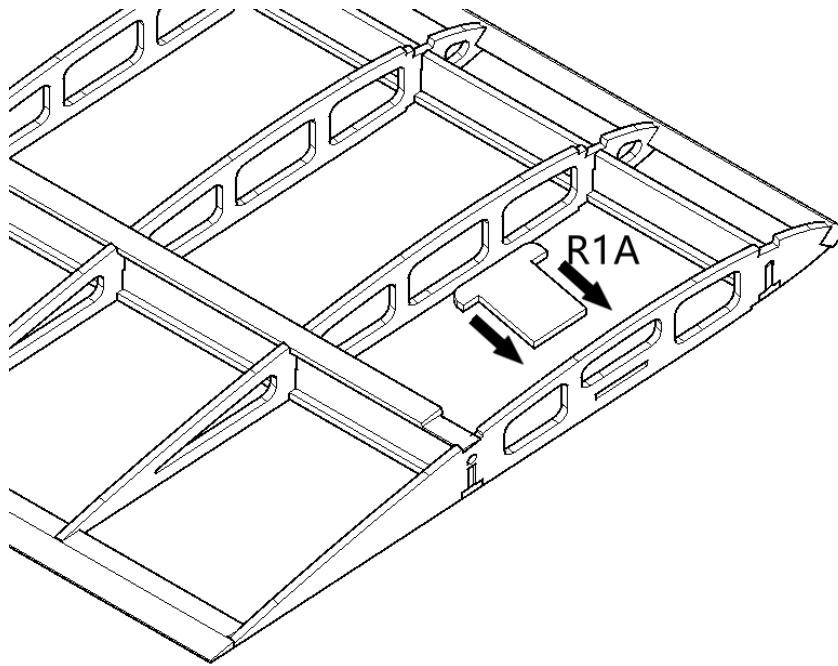

Schritt 18

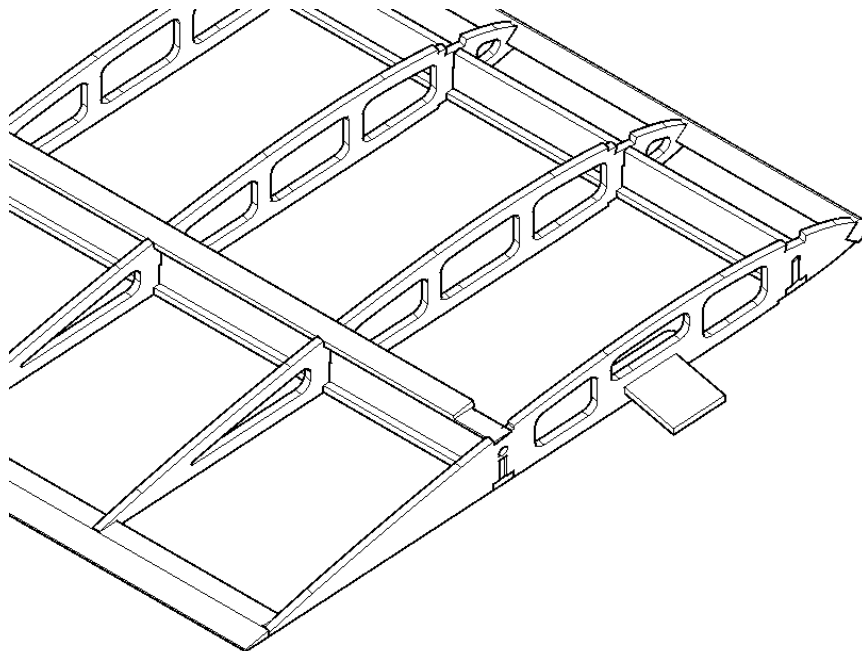

Schritt 19: 6 x 6 mm Balsa Leisten

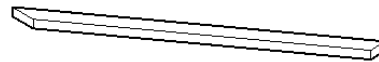
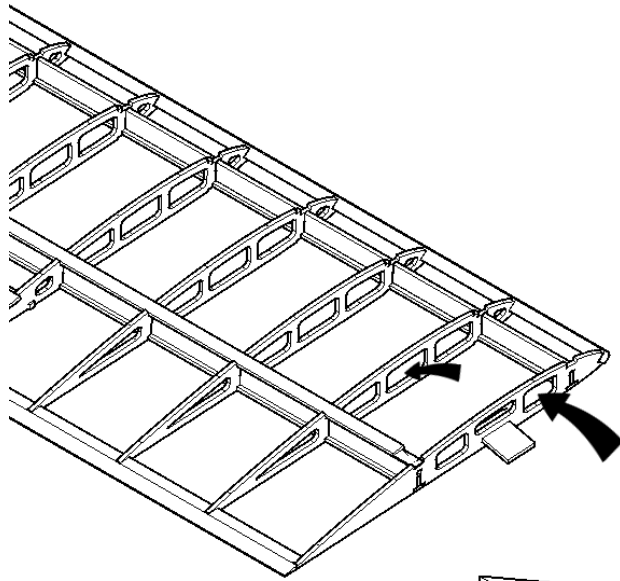

6*6mm Balsa Strips

Schritt 20

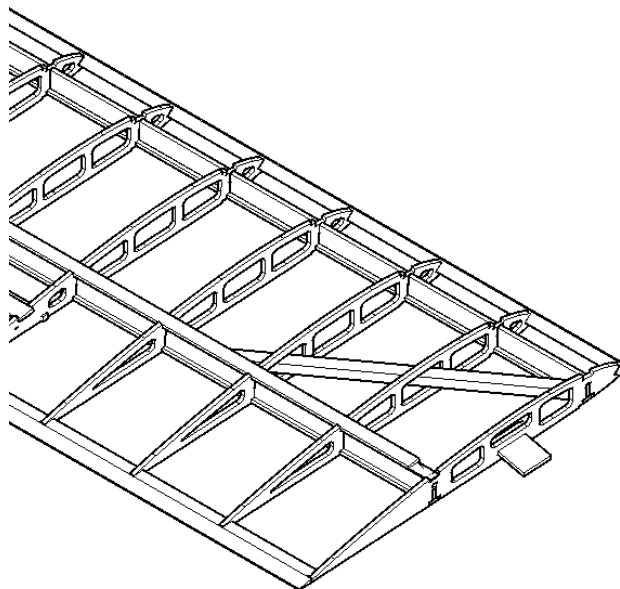

Schritt 21: 3 mm Durchmesser aufbohren.

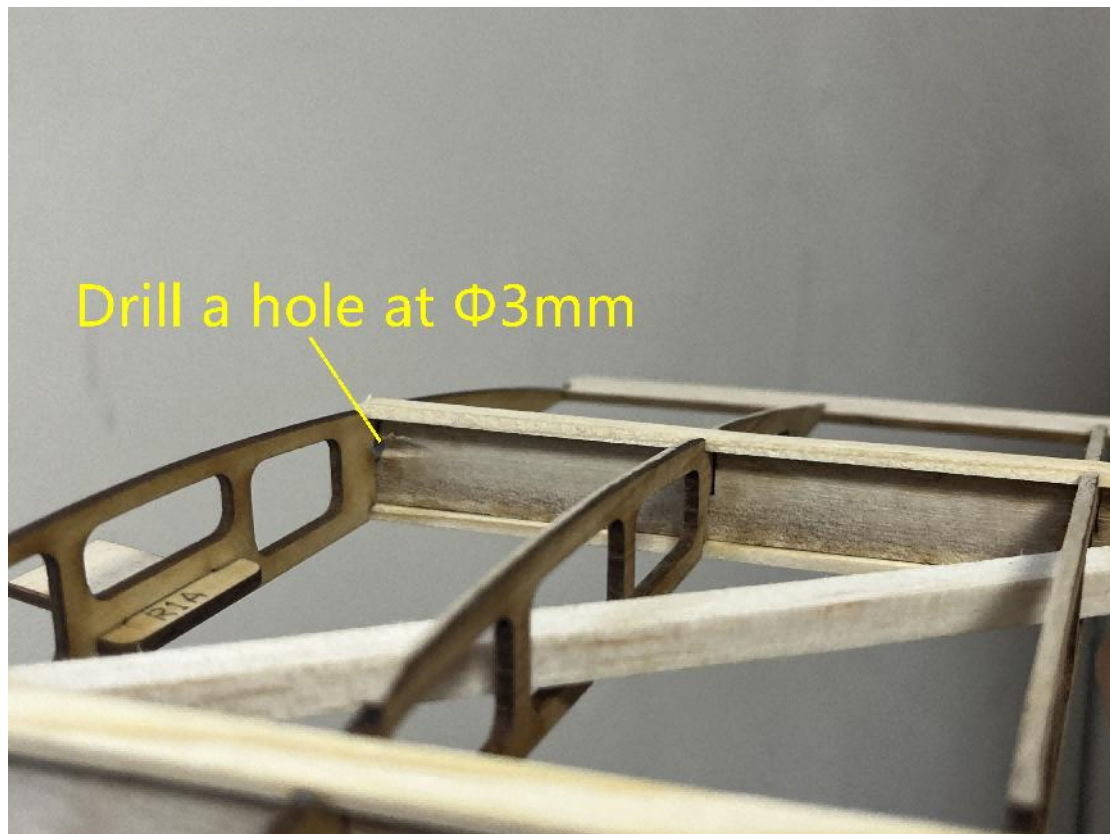

Schritt 22: 3 mm Durchmesser aufbohren.

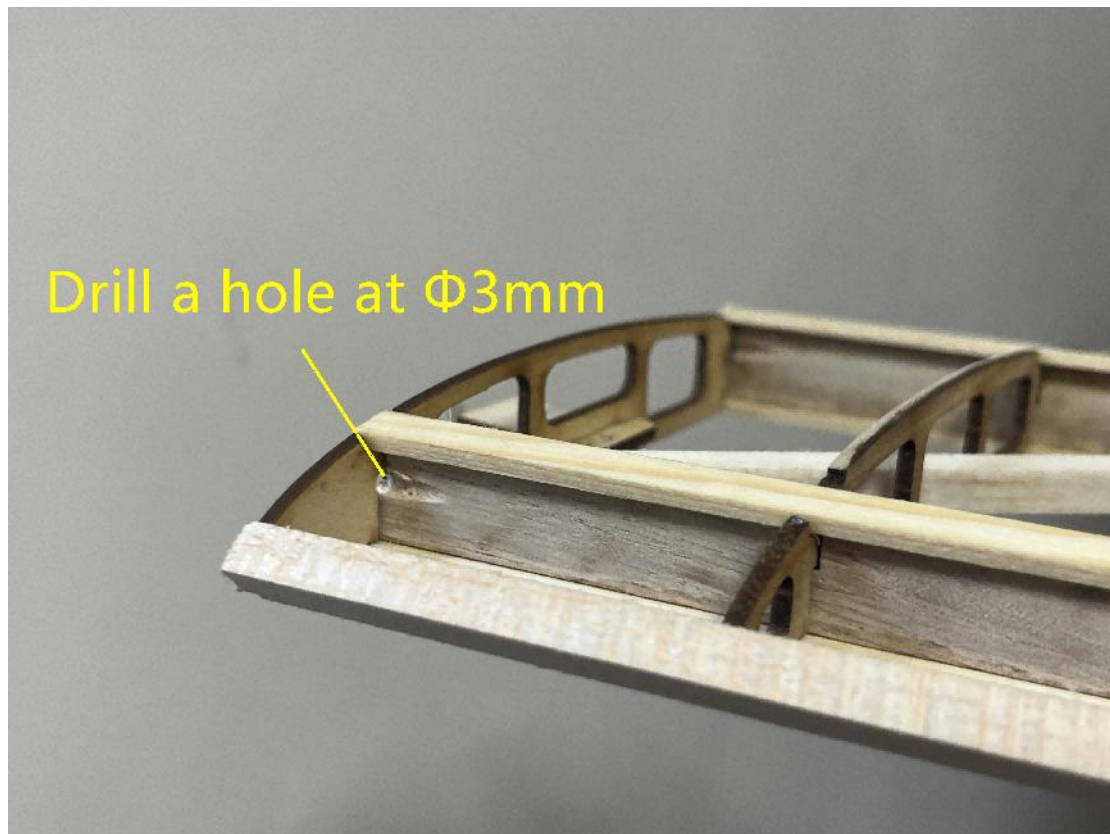

Schritt 23

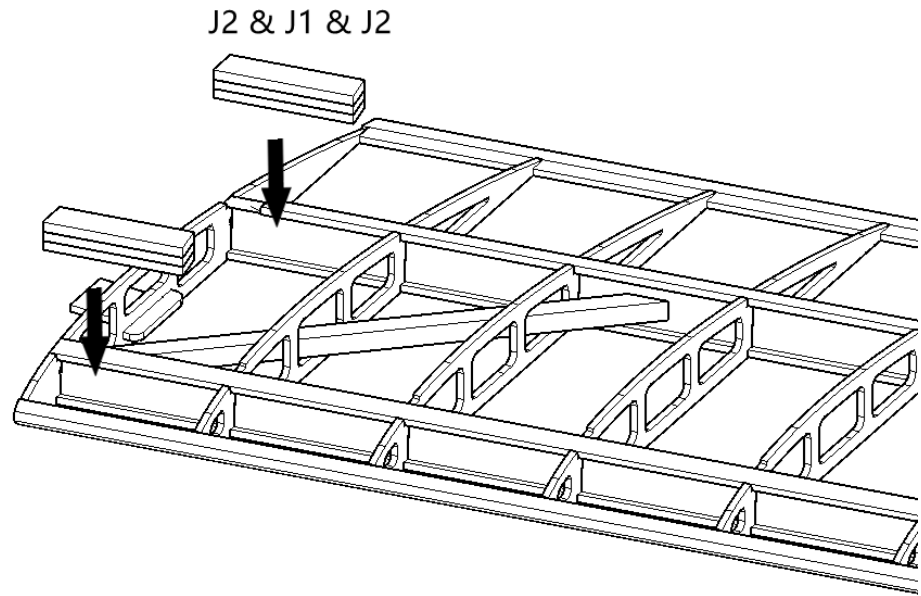

Schritt 24: Hutmutter. M3 x 30 Gewindestange.

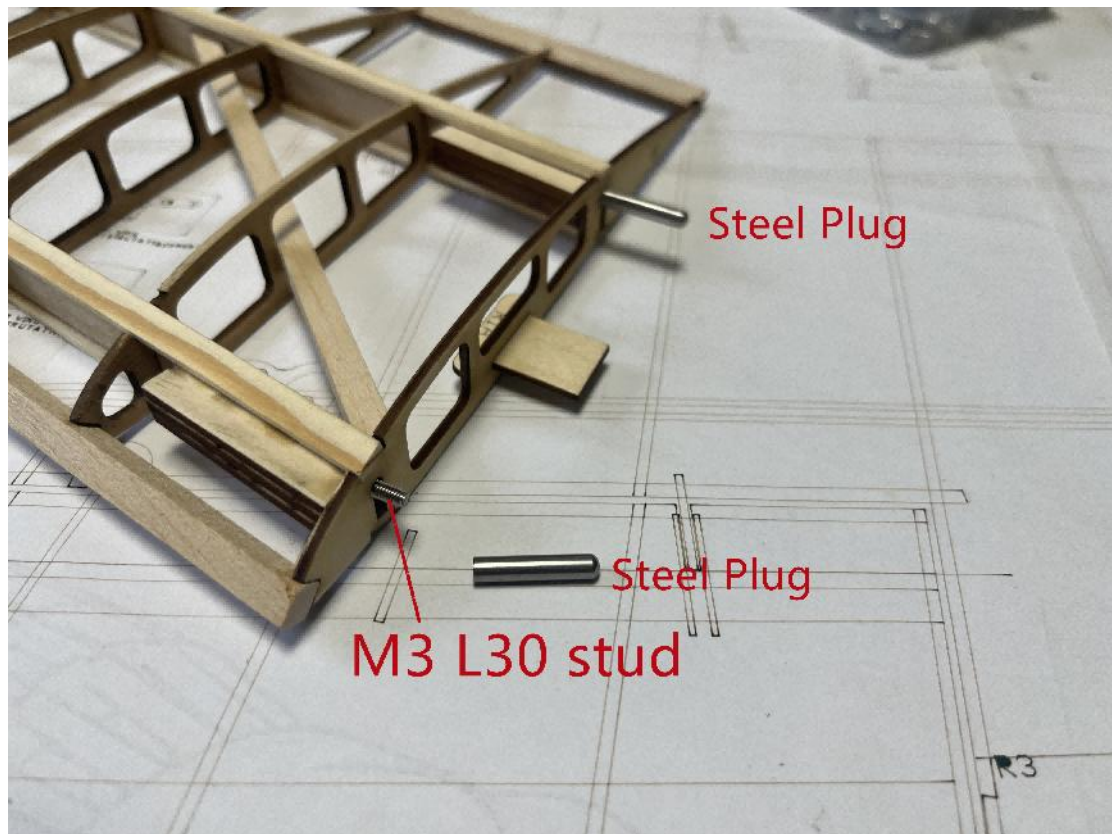

Schritt 25: Durch vorsichtiges Schleifen, Durchmesser der Hutmuttern anpassen.



Schritt 26: 1 mm tief anpassen.



Schritt 27

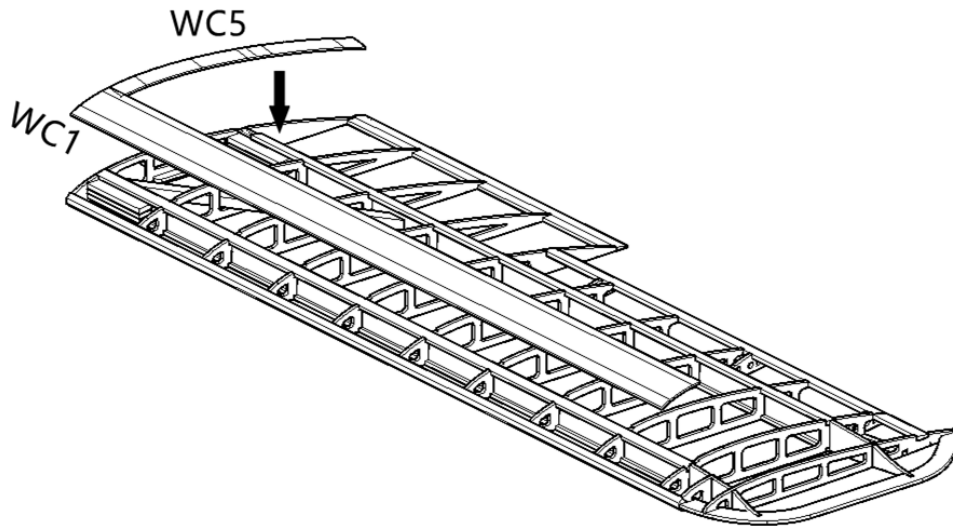

Schritt 28

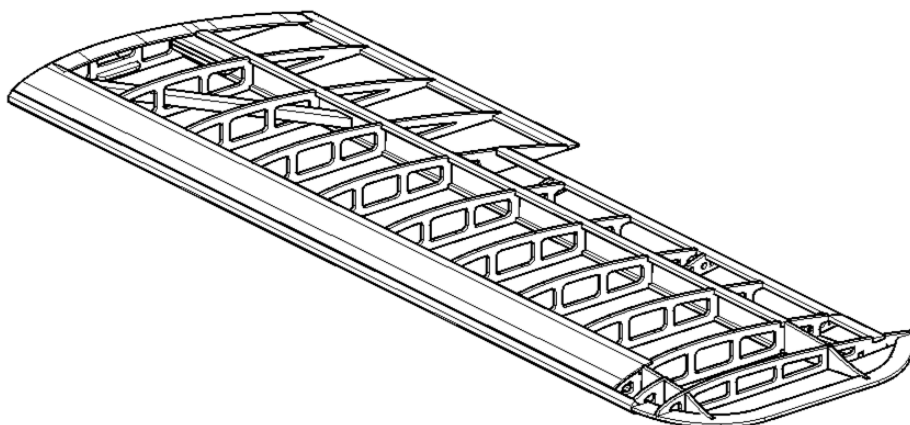

Schritt 29

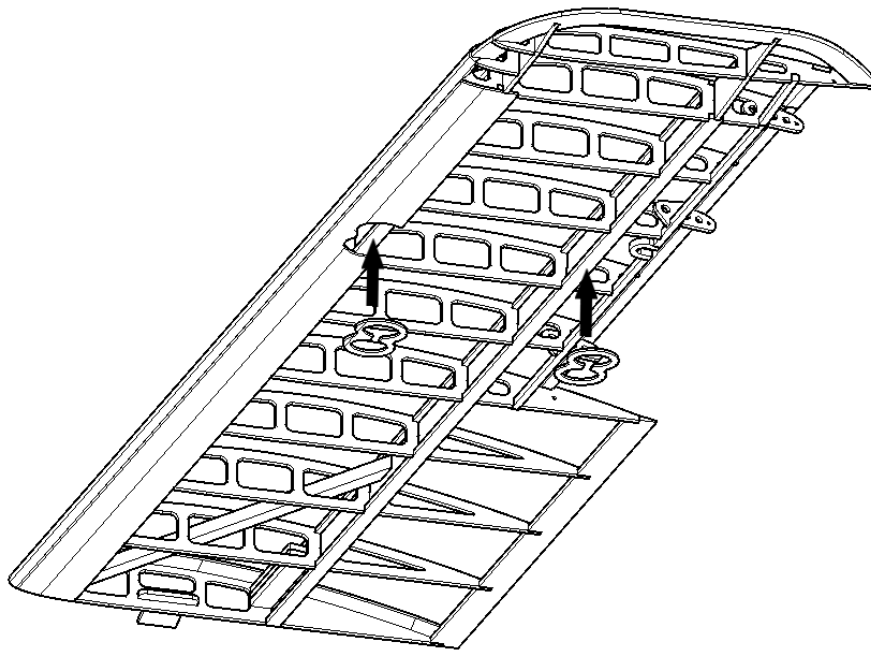

Schritt 30: Die runde Öffnung mittig über dem Kiefernholm ausrichten.

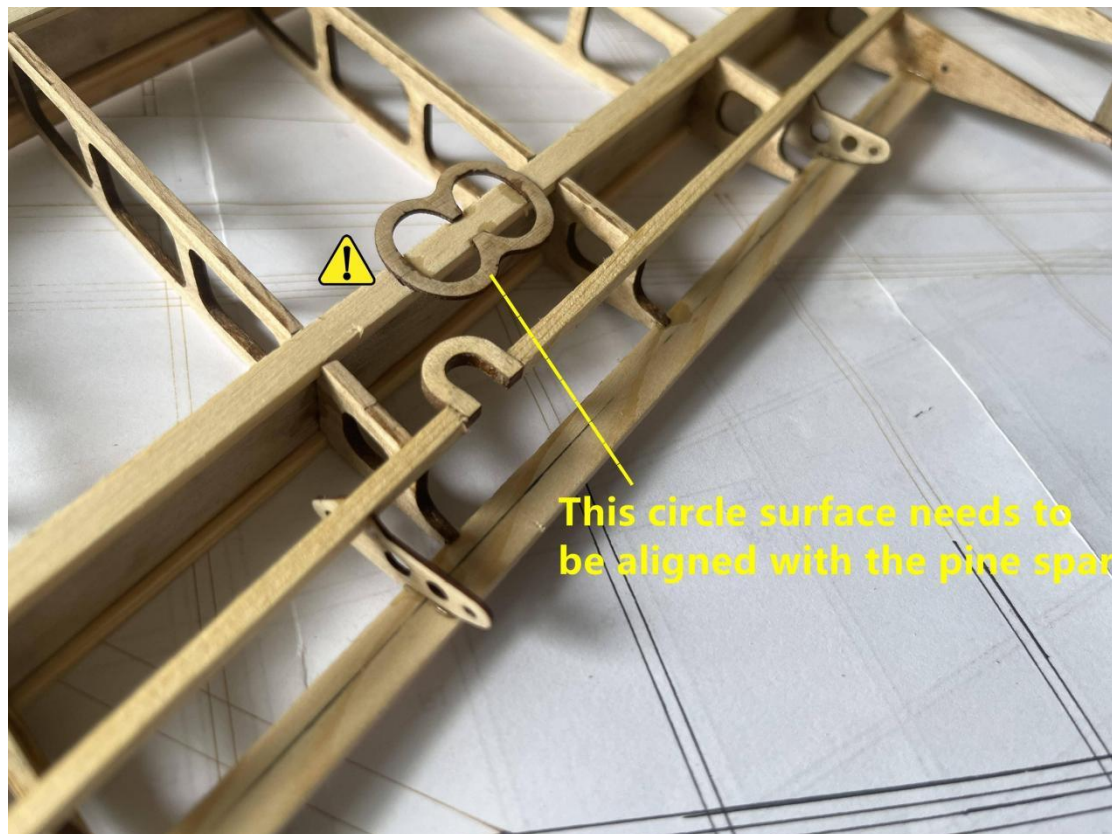

Schritt 31

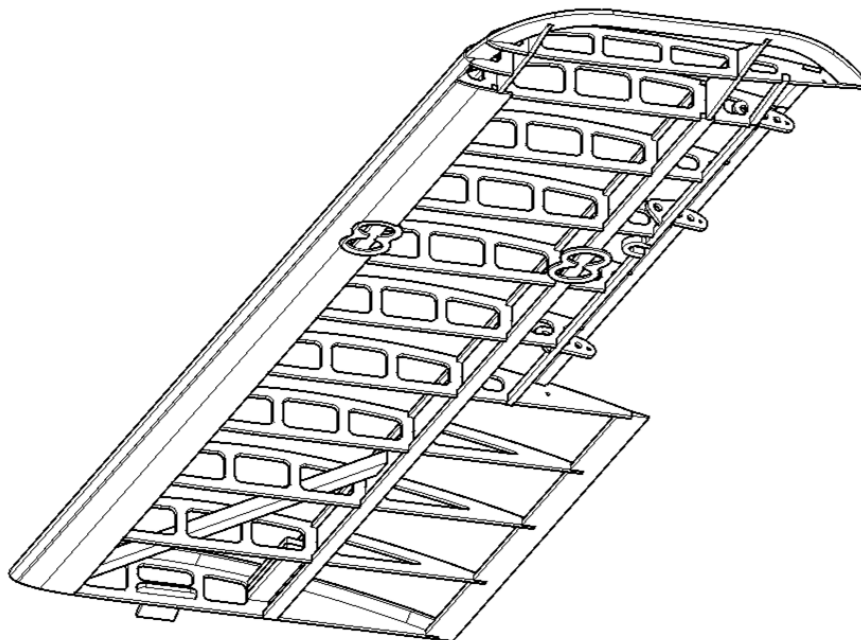

Schritt 32: Strebenanschlüsse gemäß Bauplan montieren. 225 mm Kiefernrundstab (6 mm Durchmesser, M2 Schrauben).

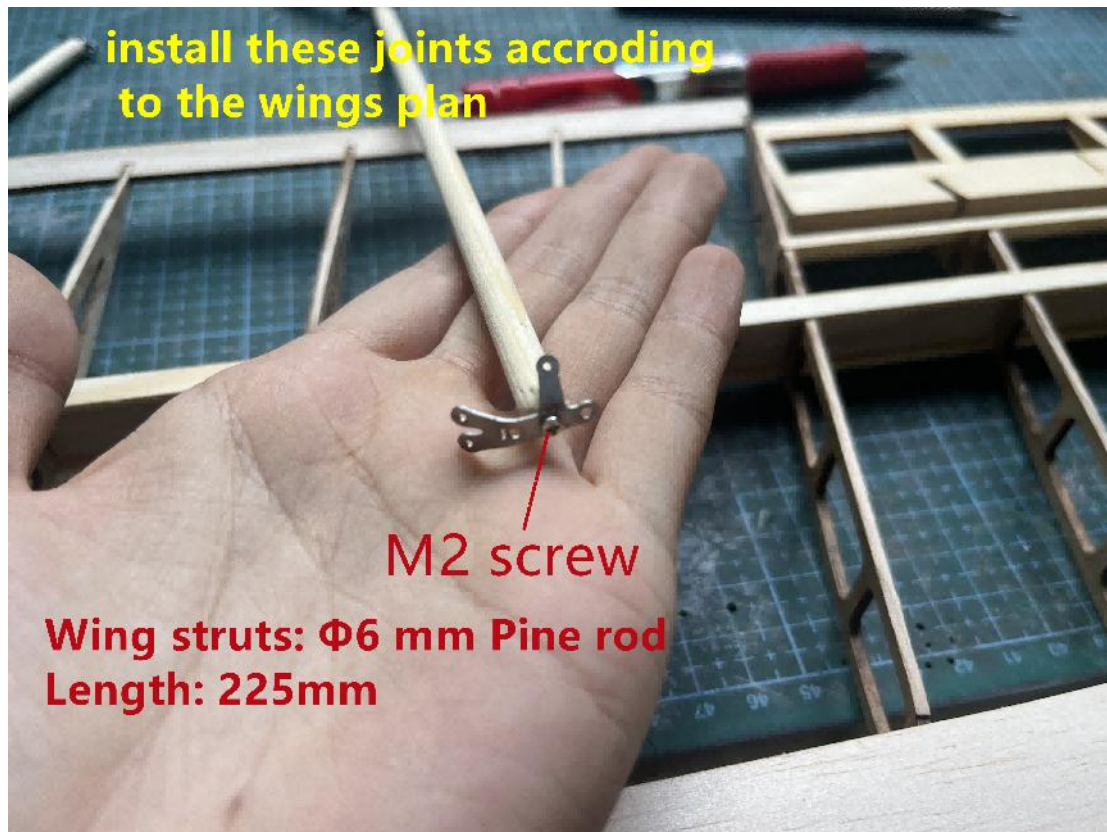

Schritt 33: Bohrung \varnothing 1,5 mm herstellen und Aussparung für den Schraubenkopf einarbeiten.

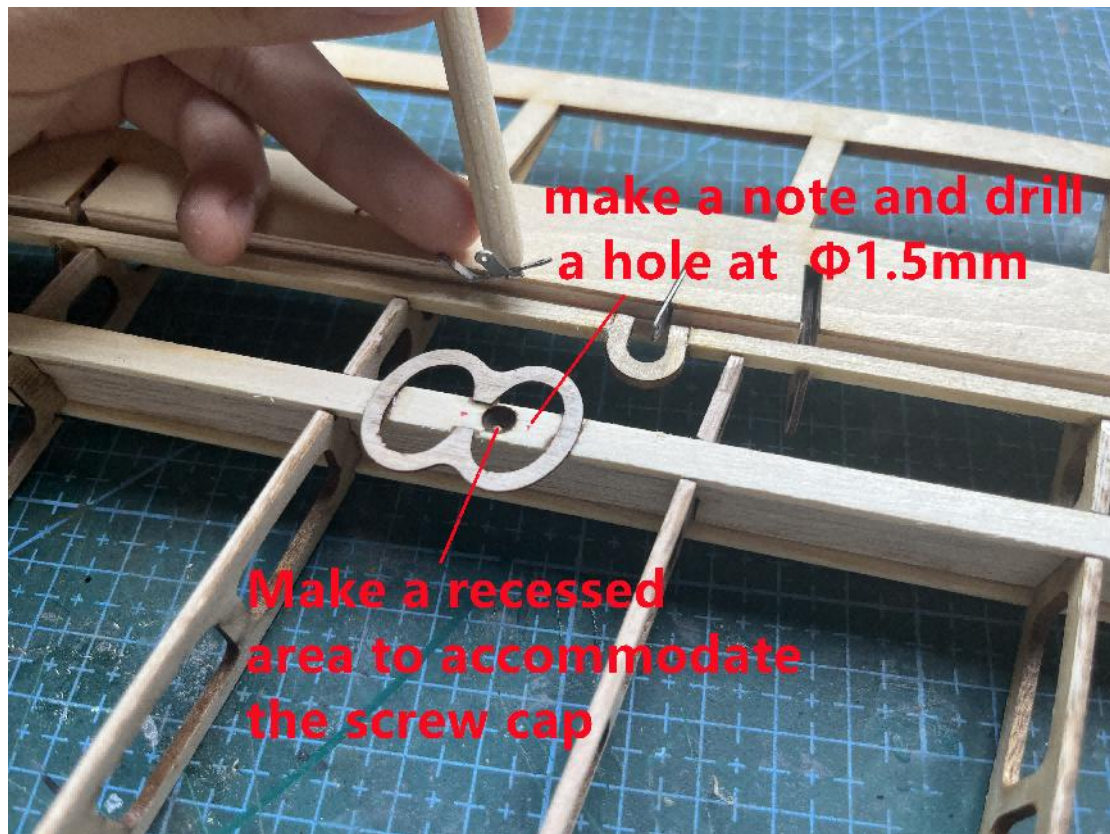

Schritt 34

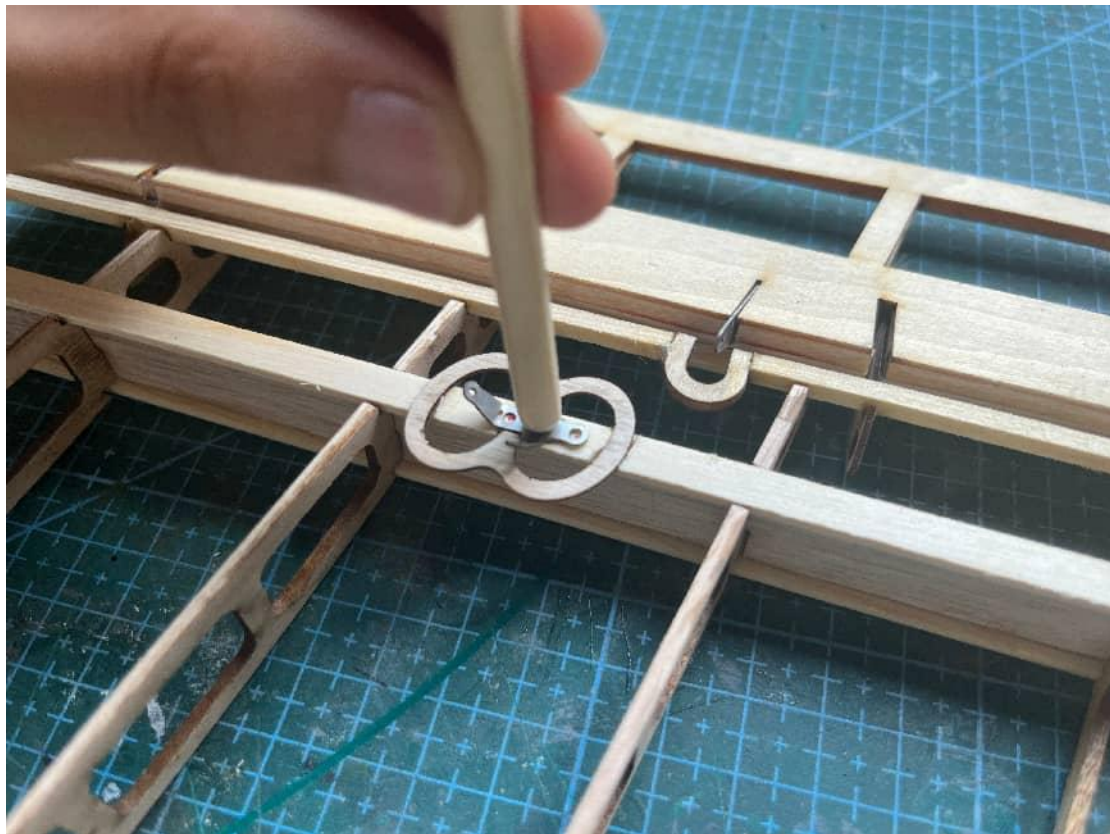

Schritt 35



Schritt 36



9. Montage - Querruder

Schritt 1: 6 x 6 mm Balsa Leisten. Ende anschrägen.

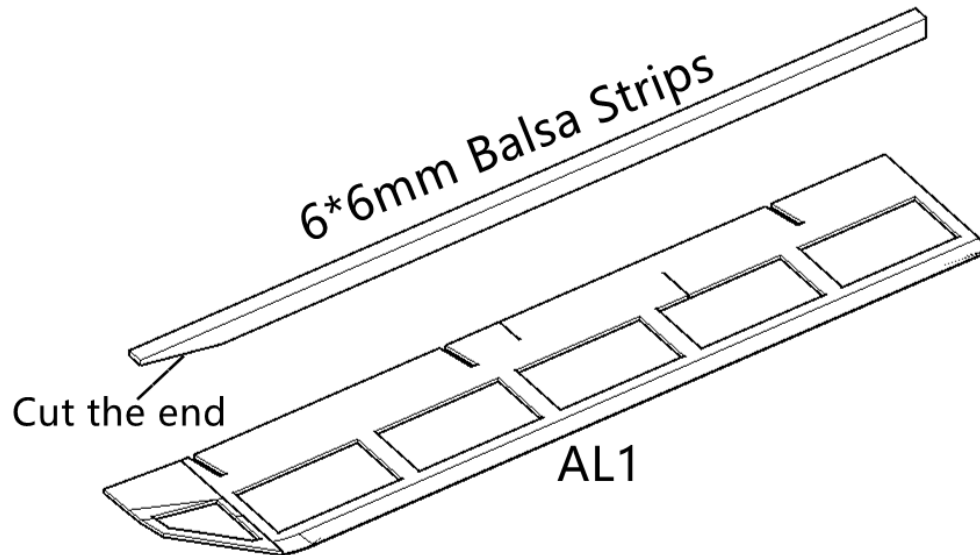

Schritt 2: 3 x 3 mm Balsa Leisten



Schritt 3

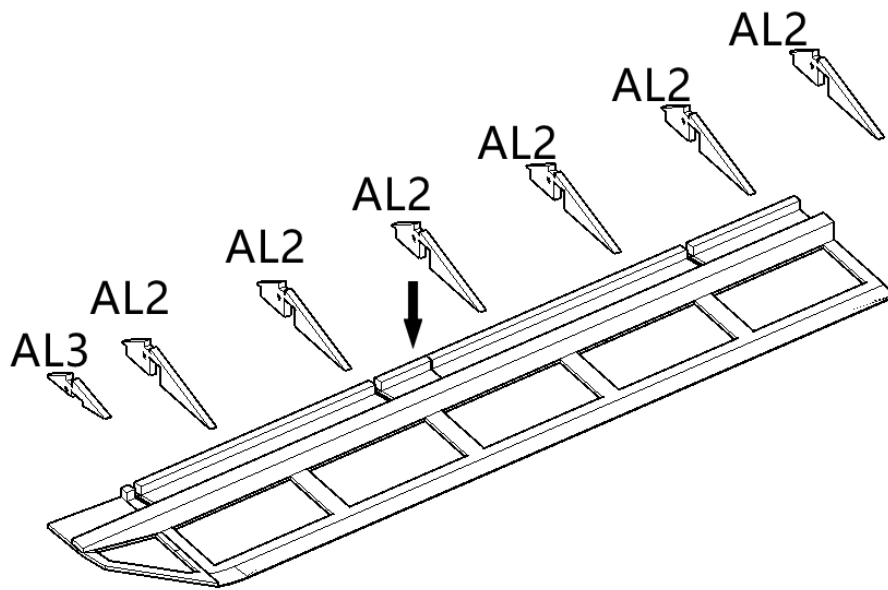

Schritt 4

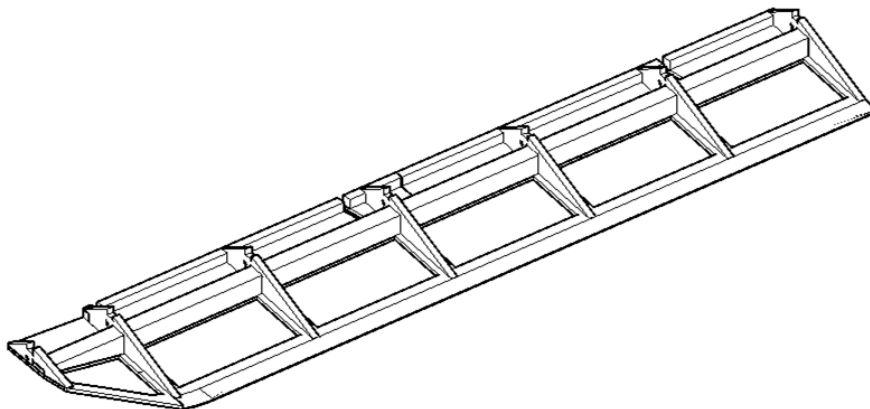

Schritt 5

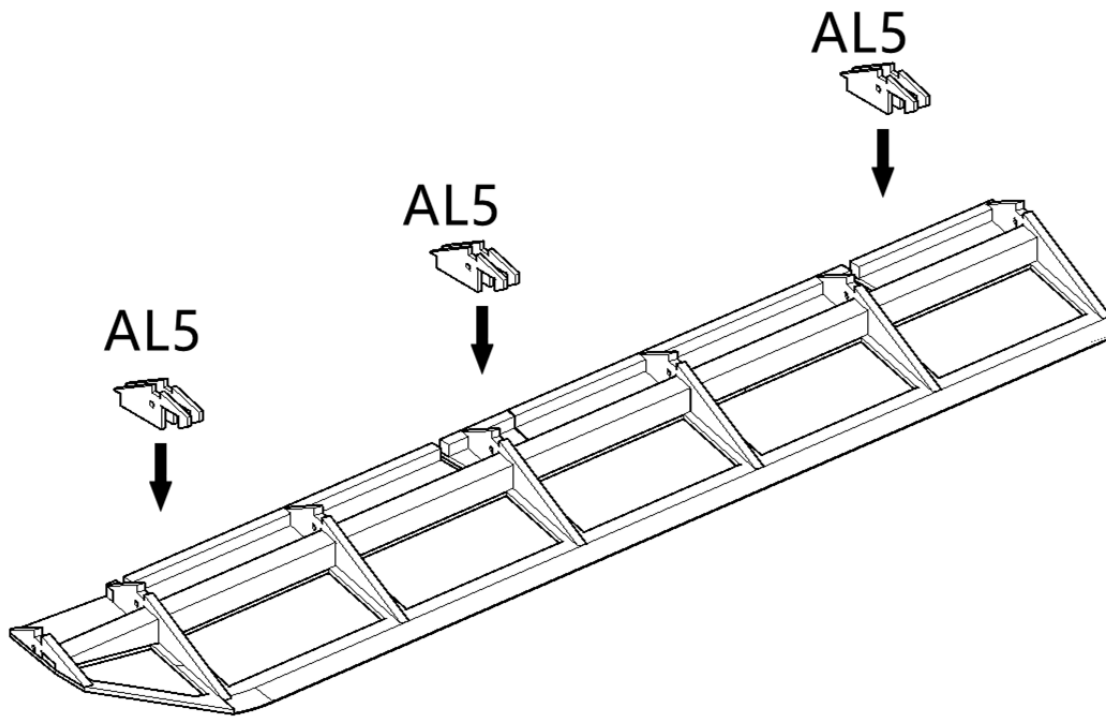

Schritt 6: Positionierung nach Abbildung beachten.

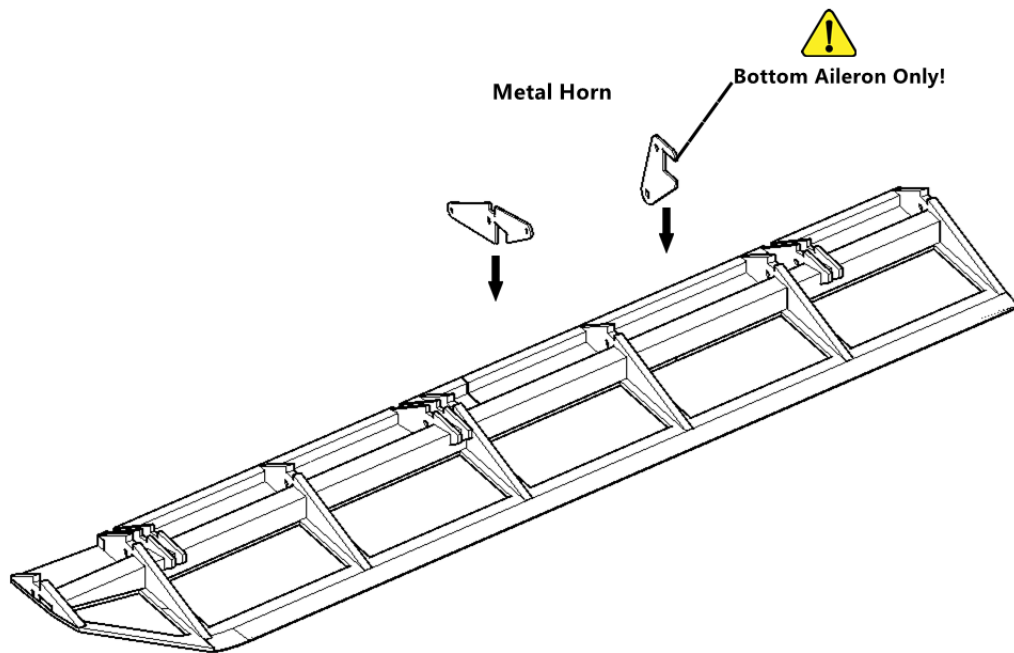

Schritt 7

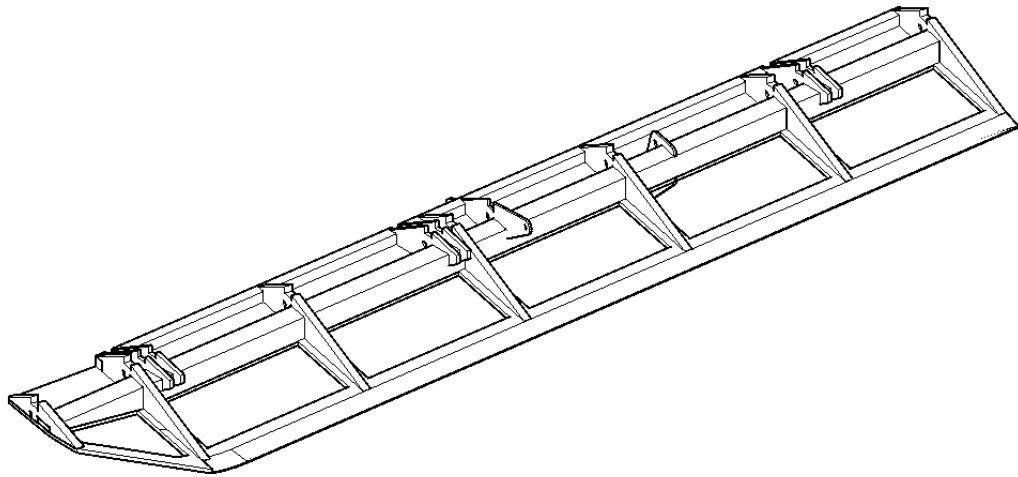

Schritt 8

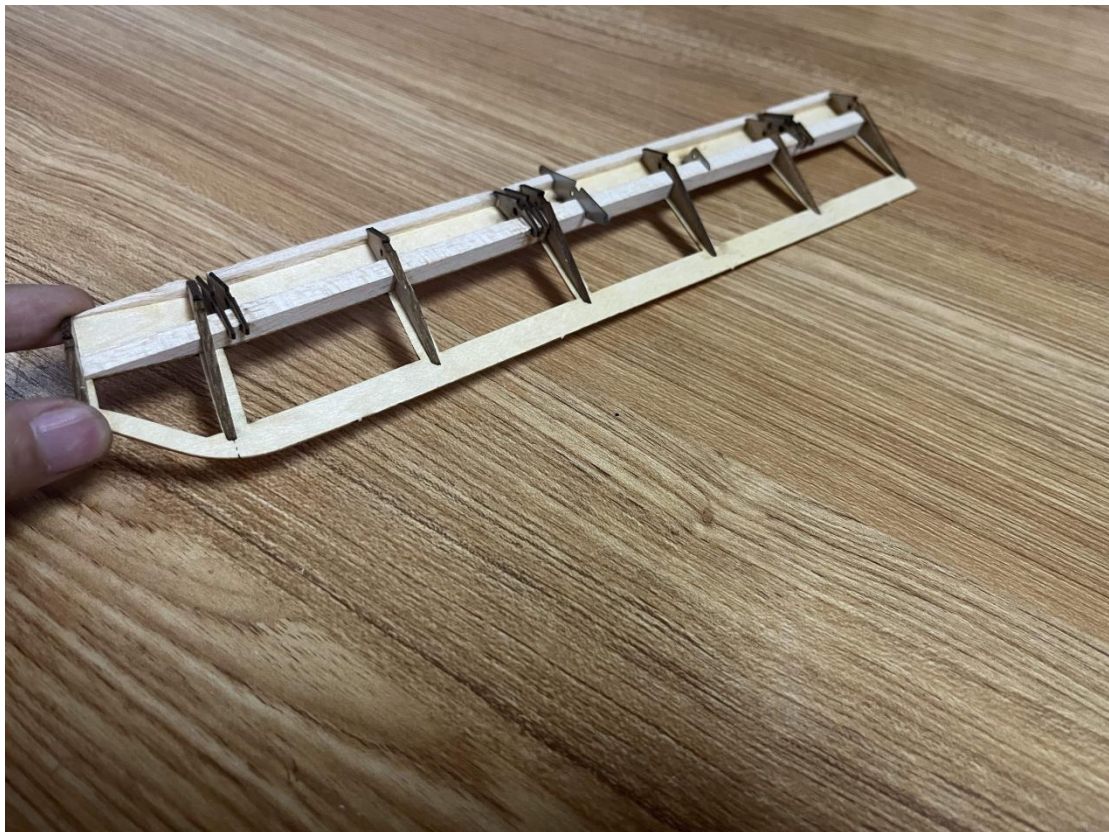

Schritt 9: 3 x 3 mm Balsa Leisten

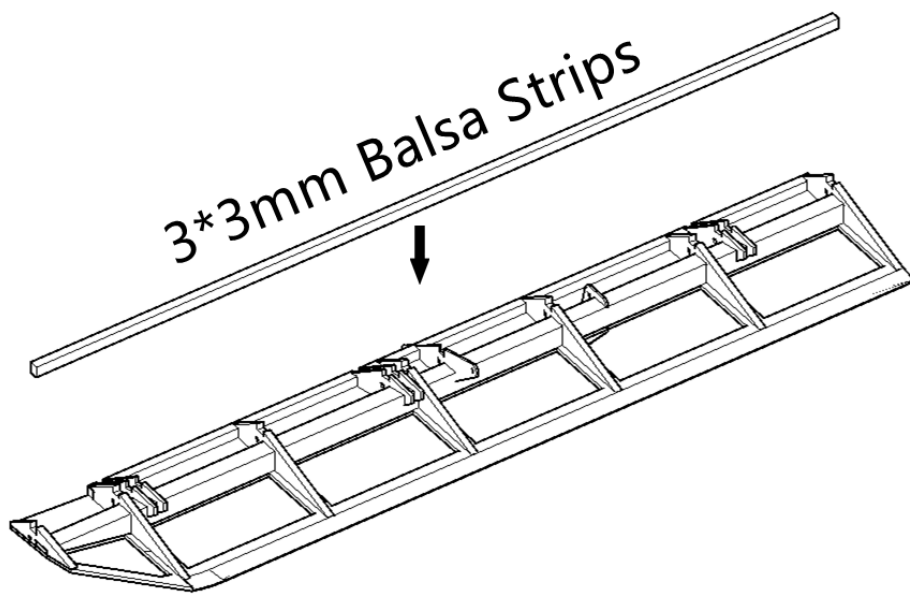

Schritt 10

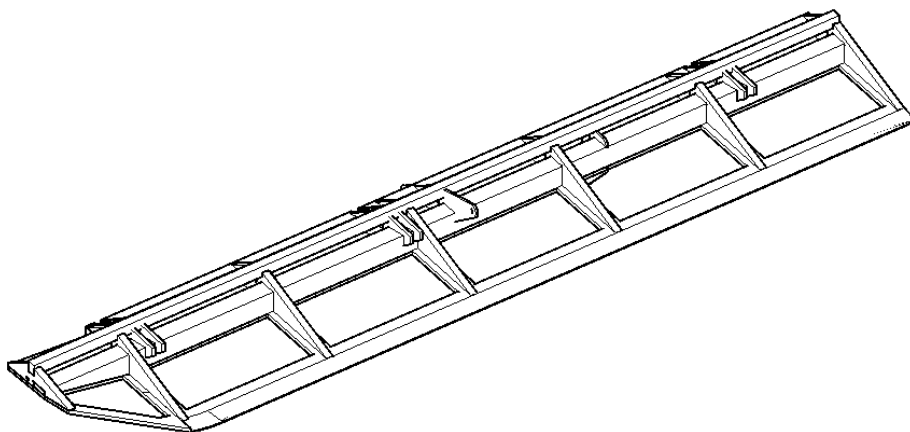

Schritt 11: 1 mm Balsa



Schritt 12: Untere Querruder (AL7) , obere Querruder (AL8)

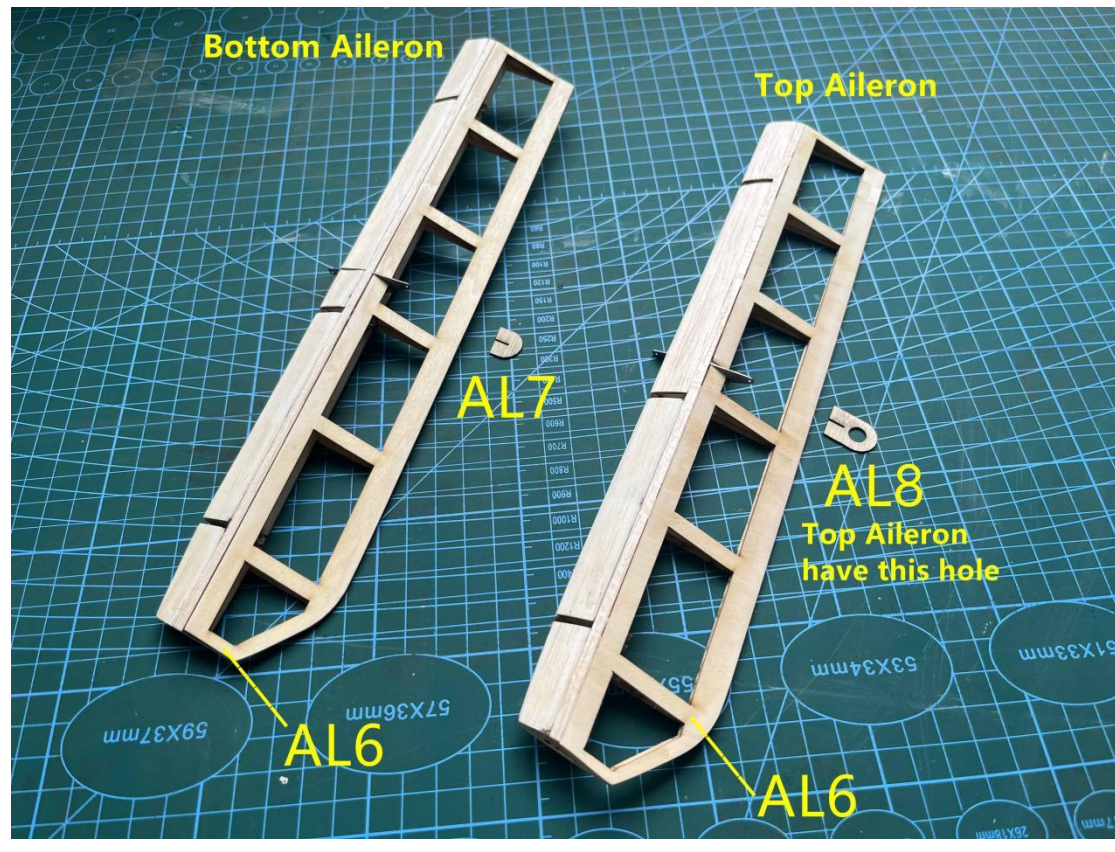

Schritt 13

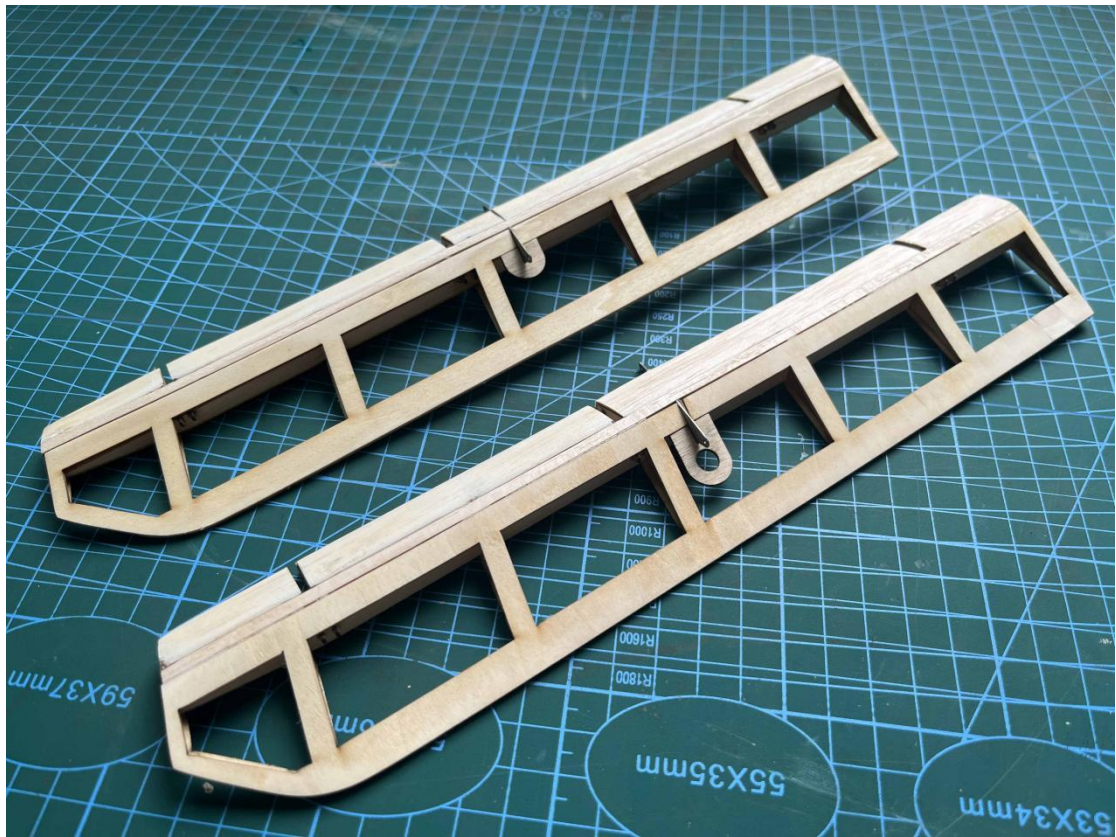

Eigene Notizen:

10. Endmontage (beispielhaft)

Schritt 1: Gestängeanschluss

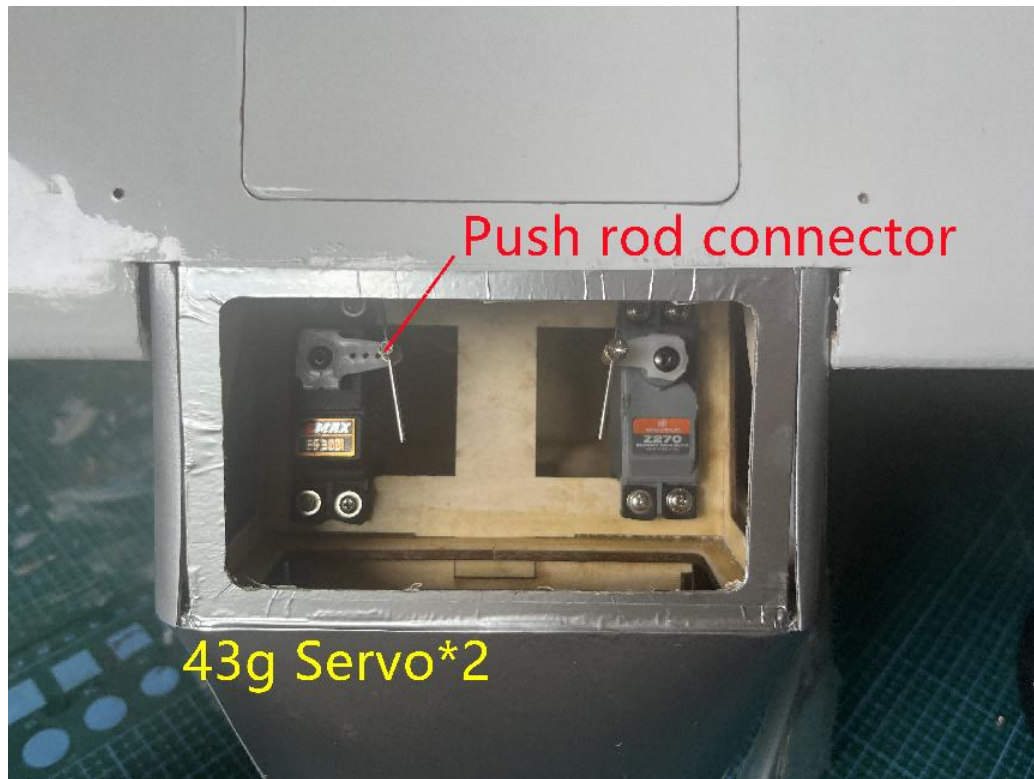

Schritt 2: Motorträger aus 0,5-mm-Aluminiumblech gemäß Schablone (Plan Seite 2 von 2) herstellen und montieren. Beispielhafte Ansicht Motormontage.



Schritt 3: 0,5 mm Metallteil. 2 x Spornrad Halter.



Schritt 4: Wippe mittig zwischen den beiden Fahrwerksbeinen montieren und die Schraube mit Schraubenlack sichern.



Schritt 5

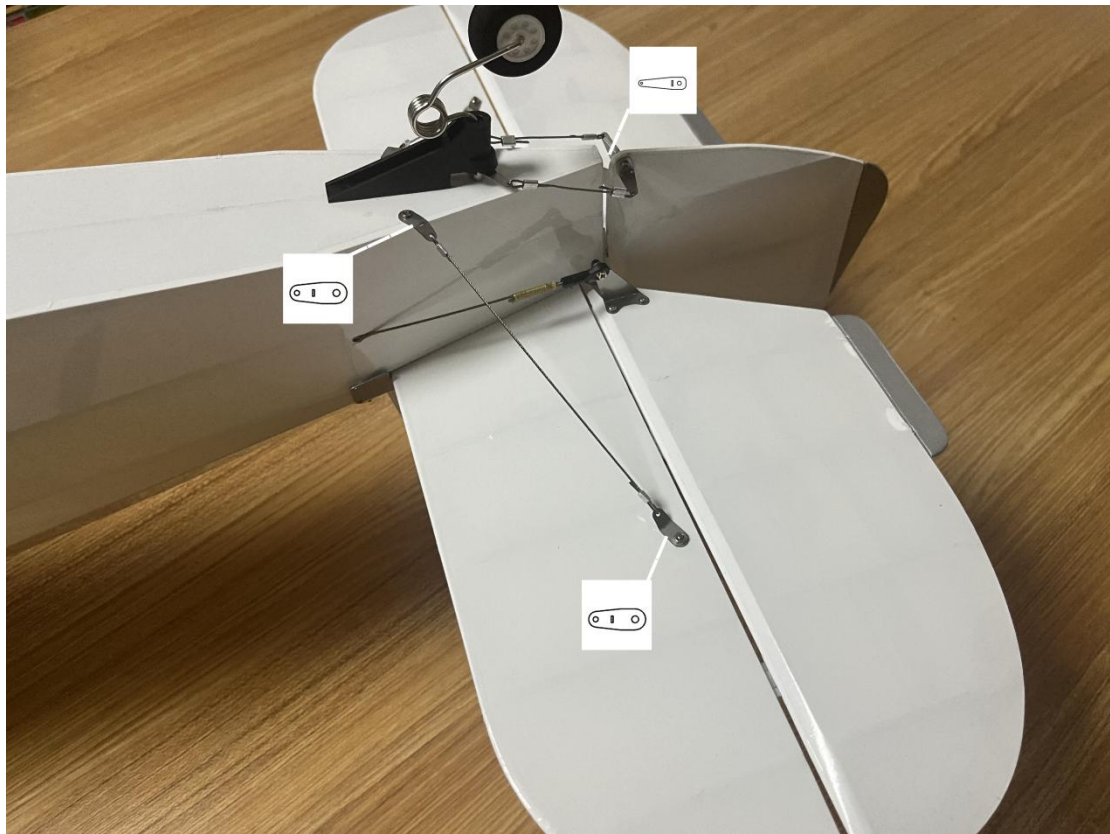

Schritt 6: M2 x 30 Gewindestange. 1,2 mm Durchmesser Stahldraht Schubstange. Kevlar und Epoxy.

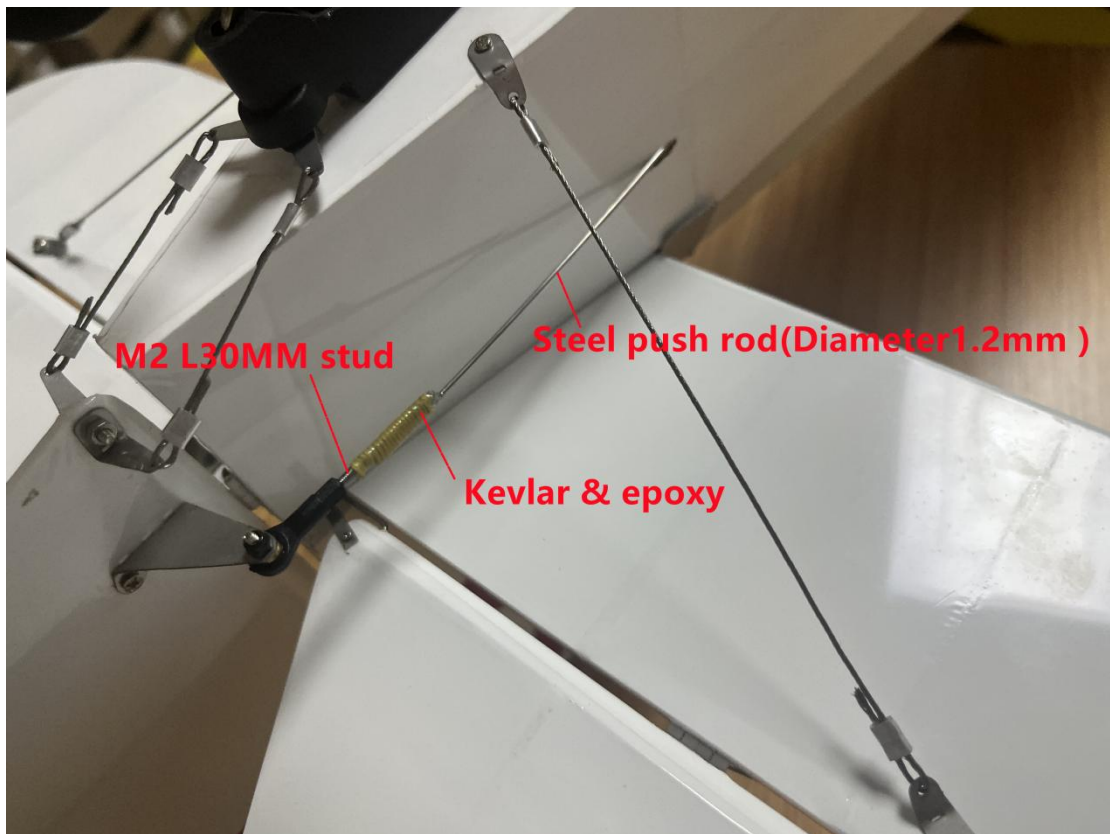

Schritt 7: Beispielhafte Servomontage



Schritt 8: M2 x 45 Gewindestange.

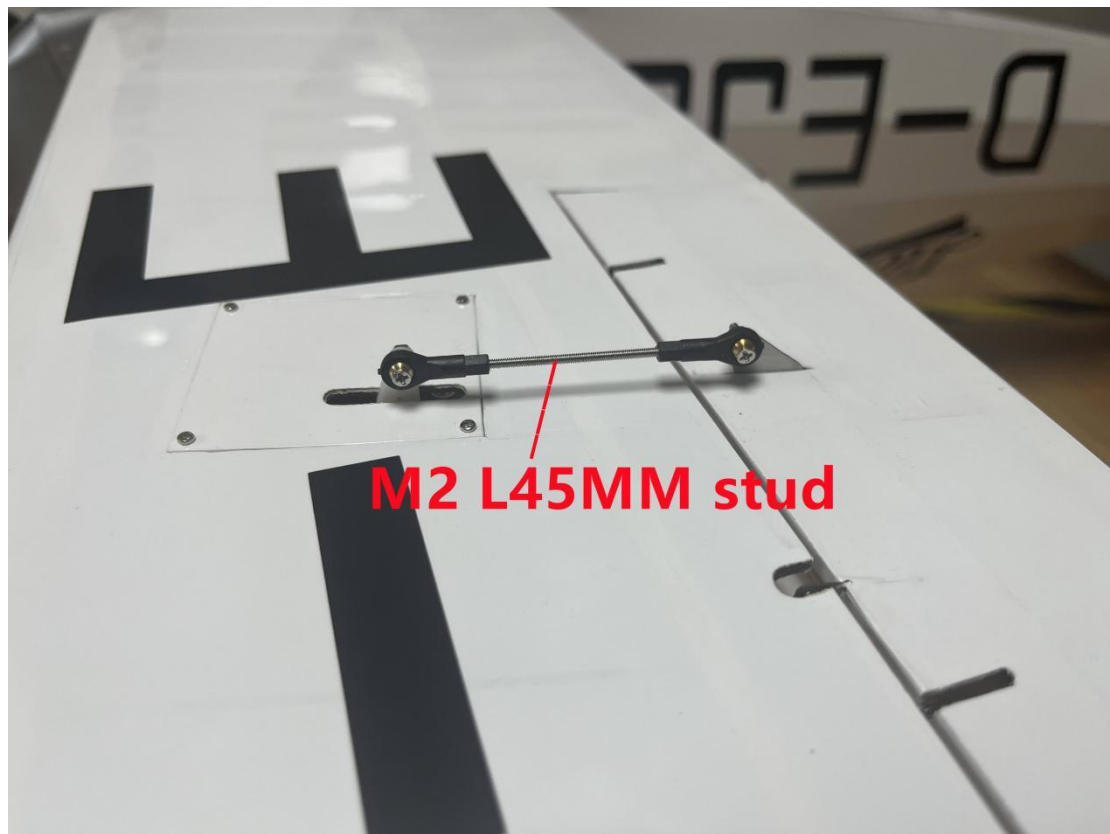

Schritt 9: Schmuckkarabiner



Schritt 10

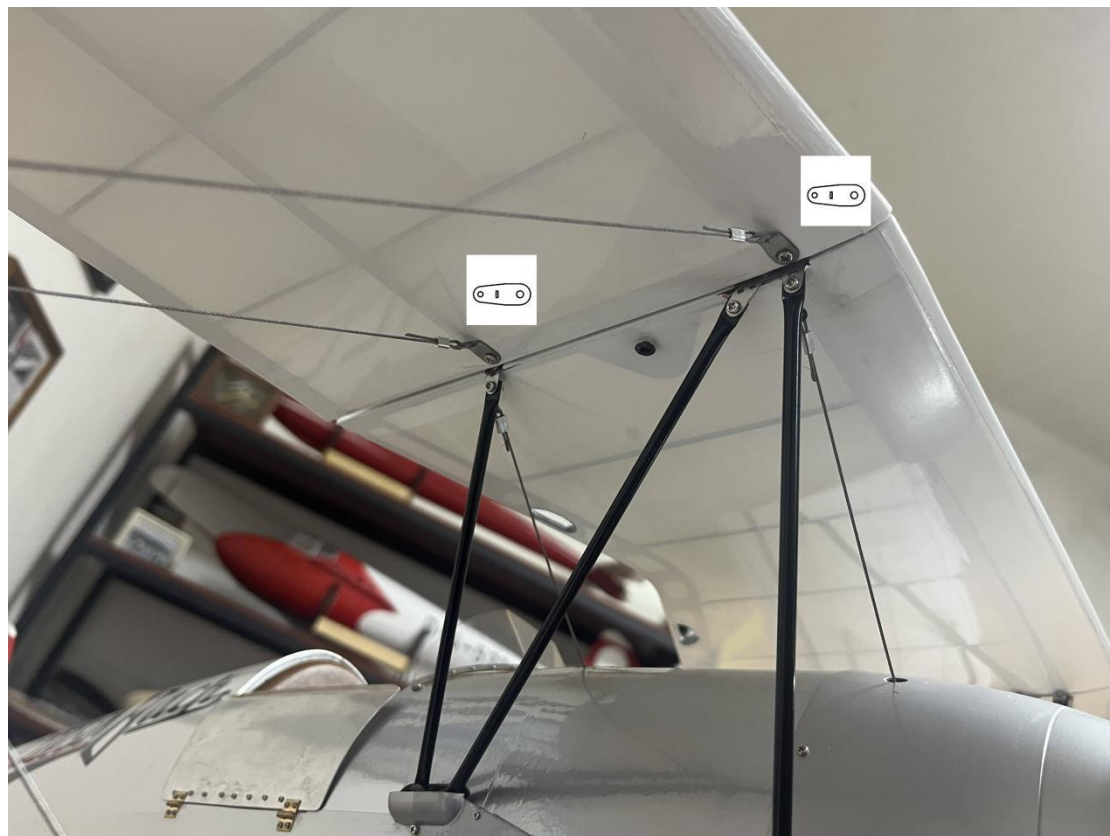

Schritt 11



Demontage der Tragflächen: Schritt 1 – Obere Tragfläche abnehmen.



Demontage der Tragflächen: Schritt 2 – Die beiden Verspannungsdrähte aus den Spanschlössern lösen.

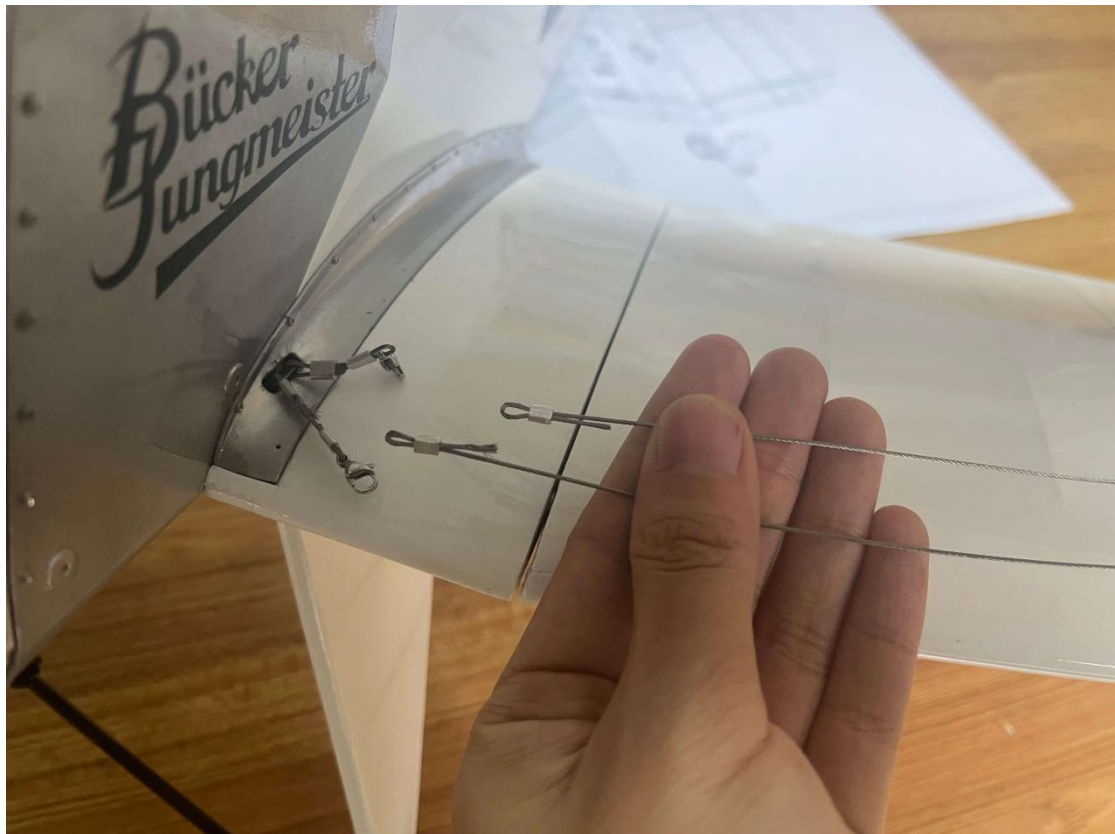

Demontage der Tragflächen: Schritt 3 – Untere Tragflächen abnehmen.





This bracket is needed to maintain the shape of the wing when the wing module is removed.

1 Diese Montagelehre verhindert ein Verziehen der Tragflächenbaugruppe nach der Demontage.



1. Schwerpunkt: 110mm von Nasenleiste

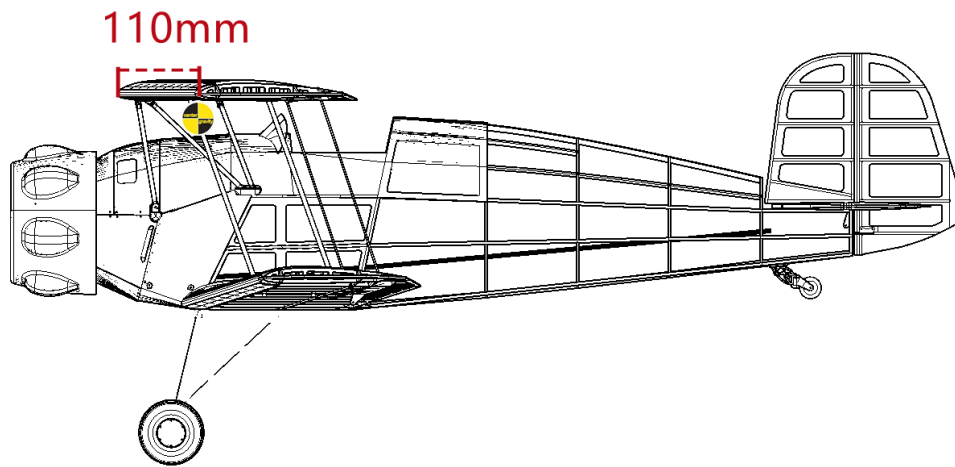

2. Einstellwinkel Höhenleitwerk: 0°

3. V-Form:

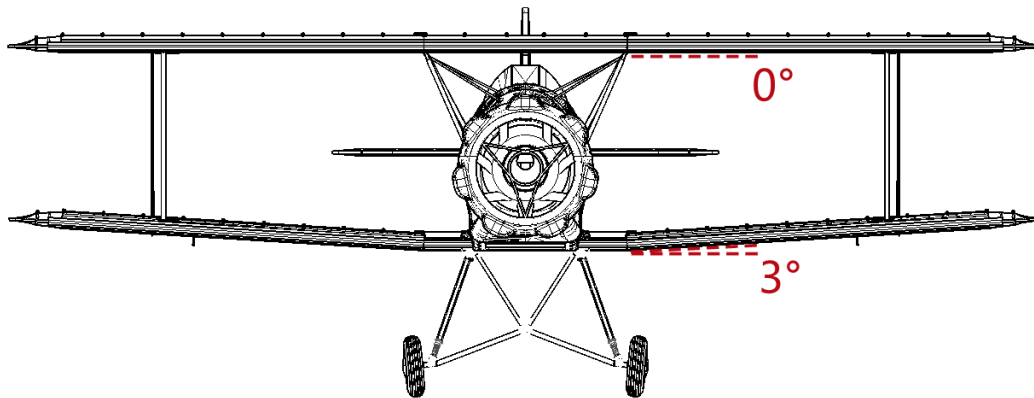

3. Steuereinstellungen	
Hoehenruder	$\pm 20^\circ$
Seitenruder	$\pm 30^\circ$
Querruder	$+15^\circ -10^\circ$

Vielen Dank!



Tony Ray's AeroModel